

P R B X

POWERBOX Industrial Line PQAE100W Series Up to 90W 4:1 Single Output High Performance DC/DC Converter

Features

No minimum load required
Low standby power consumption
3000VAC reinforced insulation for 110Vin
2250VDC basic insulation for 24Vin and 48Vin
Safety meets UL60950-1, EN60950-1, & IEC60950-1
Compliance to EN50155 and EN45545-2 railway standard
Compliance to EN45545-2 fire behavior

Input

Input voltage range	24Vin(nom)	8.5 ~ 36VDC
	48Vin(nom)	16.5 ~ 75VDC
	110Vin(nom)	40 ~ 160VDC
Start-up voltage	24Vin(nom)	9VDC, max
	48Vin(nom)	18VDC, max
	110Vin(nom)	43VDC, max
Shutdown voltage	24Vin(nom)	7.3 ~ 8.1VDC
	48Vin(nom)	15.5 ~ 16.3VDC
	110Vin(nom)	33.0 ~ 36.0VDC
Start up time	Power up	75mS, typ
	Remote ON/OFF	75mS, typ
	Constant resistive load	
Input surge voltage 1second, max	24Vin(nom)	50VDC
	48Vin(nom)	100VDC
	110Vin(nom)	185VDC
Input filter1)	Pi type	
Remote ON/OFF	Referred to -Vin pin	
	Negative logic DC-DC ON	Short or 0~1.2V
	(Standard) DC-DC OFF	Open or 3~12V
	Positive logic DC-DC ON	Open or 3~12V
	(Option) DC-DC OFF	Short or 0~1.2V
	Input current of Ctrl pin	0.5mA ~ 1mA
Remote off input current	3mA typ.	

Output

Voltage accuracy	±1%.	
Line regulation	LL to HL at full load	±0.1
Load regulation	No load to full load	
	3.3 & 5V out	±0.2
	Others	±0.1
Voltage adjustability	-20% min, +10% max. Max output deviation is inclusive of remote sense.	
Remote sense	10% of Vout (nom). If remote sense is not being used, Sense pins should be connected to corresponding polarity OUTPUT pins.	
Ripple and noise	Measured by 20MHz bandwidth.	
With a 22µF/25V X7R MLCC	3.3Vout, 5Vout	75mV p-p typ
With a 22µF/25V X7R MLCC	12Vout, 15Vout	100mV p-p typ
With a 4.7µF/50V X7R MLCC	24Vout, 28Vout	200mV p-p typ
With a 2.2µF/100V X7R MLCC	48Vout	300mV p-p typ

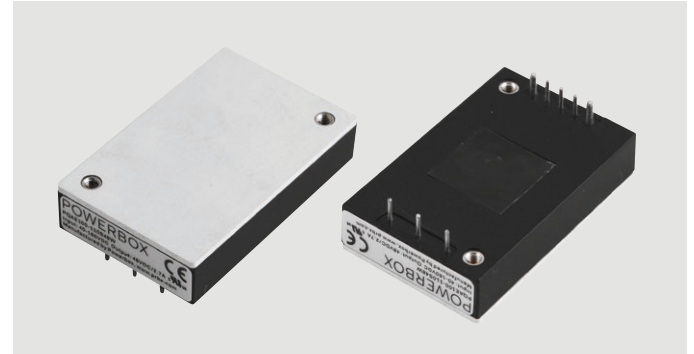

Temperature coefficient ±0.02%/°C.

Transient response	25% load step change	250µS typ
Over voltage protection	of Vout (nom); hiccup mode	115~130%
Over load protection	of Iout rated; hiccup mode	110~140%
Short circuit protection	Continuous, automatic recovery.	

Environmental

Operating temperature	Baseplate	-40 ~ 105°C
Overtmp protection	110°C typ.	
Storage temperature	-55°C to +125°C.	
Thermal impedance	Without heat-sink	9°C/W
	Mount on 2U iron base-plate	2.8°C/W
	With 0.24"height heat-sink	7.1°C/W
	With 0.5"height heat-sink	5.5°C/W
Thermal shock	MIL-STD-810F.	
Shock	EN61373, MIL-STD-810F.	
Vibration	EN61373, MIL-STD-810F.	
Relative humidity	5-95% RH.	

General

Isolation voltage	1 minute (reinforced insulation)	
	110Vin(nom) Input to output	3000VAC min
	Input (output) to base-plate	1500VDC min
	1 minute (basic insulation)	
	Others Input to output	2250VDC min
	Input (output) to base-plate	2250VDC min
Isolation resistance	500VDC	1GW min.
Isolation capacitance	1500pF, max.	
Switching frequency	300KHz, typ.	
Case material	Aluminum base-plate with plastic case.	
Potting material	Silicon (UL94-V0).	
MTBF	MIL-HDBK-217F, full load	5.070 x 10 ⁵ hrs
Weight	64g.	

Standards

Safety approvals	IEC /UL/ EN60950-1, EN50155.
Fire behavior	EN45545-2.

POWERBOX Industrial Line
PQAE100W Series
 Up to 90W 4:1 Single Output
 High Performance
 DC/DC Converter

EMC Parameter		Conditions	Level
EMI	EN55011, EN55032	With external components	Class A, Class B
ESD	EN61000-4-2	Air $\pm 8\text{kV}$ and Contact $\pm 6\text{kV}$	Perf. Criteria A
Radiated immunity	EN61000-4-3	20 V/m	Perf. Criteria A
Fast transient	EN61000-4-4	$\pm 2\text{kV}$	Perf. Criteria A
Surge	PQAE100-24S□□W	With 2 pcs of aluminum electrolytic capacitor	Perf. Criteria A
	PQAE100-48S□□W	(Nippon chemi-con KY series, 220 μF /100V)	
	PQAE100-110S□□W	With 3 pcs of aluminum electrolytic capacitor	
Surge	EN61000-4-5	EN55024: $\pm 2\text{kV}$ and EN50155: $\pm 2\text{kV}$	Perf. Criteria A
	PQAE100-24S□□W	With 2 pcs of aluminum electrolytic capacitor	
	PQAE100-48S□□W	(Nippon chemi-con KY series, 220 μF /100V)	
Surge	PQAE100-110S□□W	With 3 pcs of aluminum electrolytic capacitor	Perf. Criteria A
		(Ruby-con BXF series, 100 μF /250V)	
Conducted immunity	EN61000-4-6	10 Vr.m.s	Perf. Criteria A
Power frequency magnetic field	EN61000-4-8	100A/m continuous; 1000A/m 1 second	Perf. Criteria A

Note:

- Input source impedance: The power module will operate as specifications without external components, assuming that the source voltage has a very low impedance and reasonable input voltage regulation. Highly inductive source impedances can affect the stability of the power module. Since real-world voltage source has finite impedance, performance can be improved by adding external filter capacitor. The PQAE100-24S□□W and PQAE100-48S□□W recommended Nippon Chemi-con KY series, 100 μF /100V. The PQAE100-110S□□W recommended Ruby-con BXF series, 39 μF /200V.
 - BASE-PLATE GROUNDING: When connect two screw bolts to shield plane, the EMI could be reduced.
- CAUTION: This power module is not internally fused. An input line fuse must always be used

Derating Curve

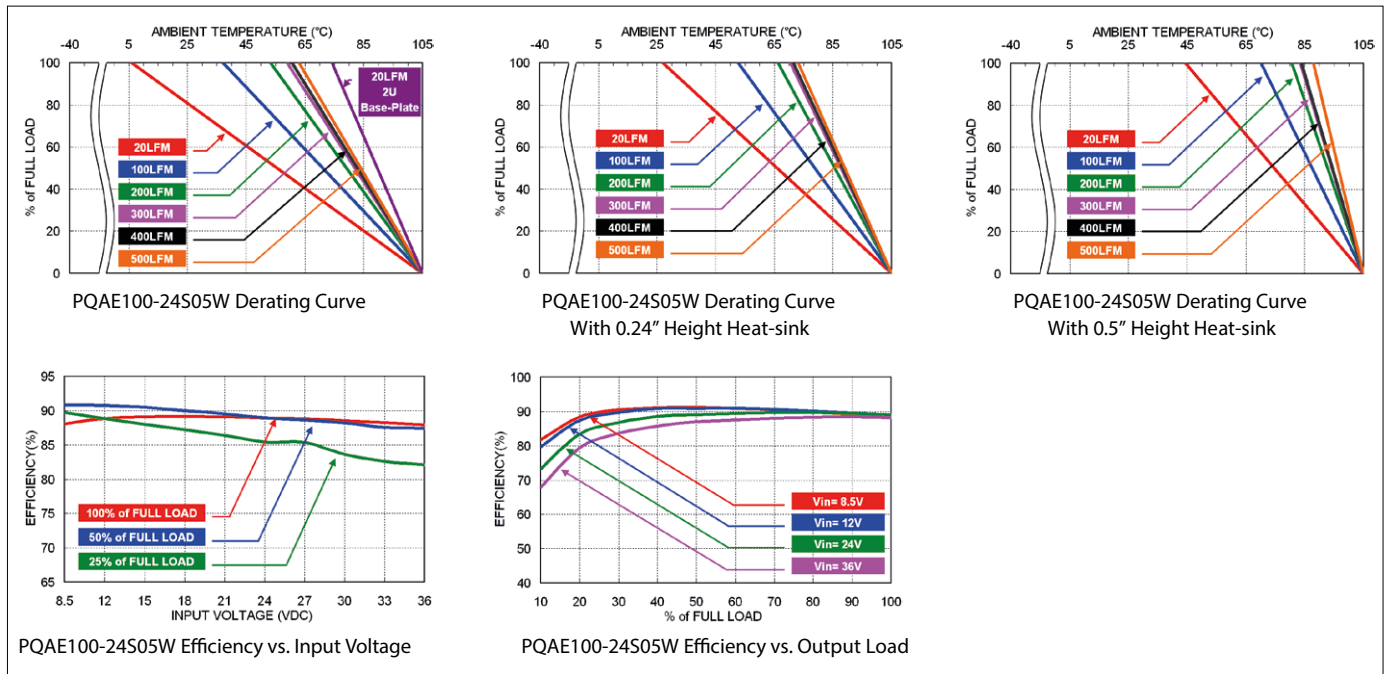

POWERBOX Industrial Line
PQAE100W Series
Up to 90W 4:1 Single Output
High Performance
DC/DC Converter

Model Number	Input Range	Output Voltage	Output Current @Full Load	Input Current @No Load	Efficiency	Max Capacitor Load
PQAE100-24S3P3W	8.5 ~ 36 VDC	3.3 VDC	25 A	25 mA	88 %	75000 µF
PQAE100-24S05W	8.5 ~ 36 VDC	5 VDC	18 A	25 mA	89 %	36000 µF
PQAE100-24S12W	8.5 ~ 36 VDC	12 VDC	7.5 A	25 mA	89 %	6250 µF
PQAE100-24S15W	8.5 ~ 36 VDC	15 VDC	6 A	25 mA	89 %	4000 µF
PQAE100-24S24W	8.5 ~ 36 VDC	24 VDC	3.7 A	25 mA	89 %	1540 µF
PQAE100-24S30W	8.5 ~ 36 VDC	30 VDC	3 A	25 mA	89 %	1000 µF
PQAE100-24S48W	8.5 ~ 36 VDC	48 VDC	1.8 A	25 mA	88 %	380 µF
PQAE100-48S3P3W	16.5 ~ 75 VDC	3.3 VDC	25 A	15 mA	88 %	75000 µF
PQAE100-48S05W	16.5 ~ 75 VDC	5 VDC	18 A	15 mA	89 %	36000 µF
PQAE100-48S12W	16.5 ~ 75 VDC	12 VDC	7.5 A	15 mA	89 %	6250 µF
PQAE100-48S15W	16.5 ~ 75 VDC	15 VDC	6 A	15 mA	90 %	4000 µF
PQAE100-48S24W	16.5 ~ 75 VDC	24 VDC	3.7 A	15 mA	90 %	1540 µF
PQAE100-48S30W	16.5 ~ 75 VDC	30 VDC	3 A	15 mA	90 %	1000 µF
PQAE100-48S48W	16.5 ~ 75 VDC	48 VDC	1.8 A	15 mA	90 %	380 µF
PQAE100-110S3P3W	40 ~ 160 VDC	3.3 VDC	23 A	8 mA	88 %	70000 µF
PQAE100-110S05W	40 ~ 160 VDC	5 VDC	17 A	8 mA	89 %	34000 µF
PQAE100-110S12W	40 ~ 160 VDC	12 VDC	7 A	8 mA	89 %	5830 µF
PQAE100-110S15W	40 ~ 160 VDC	15 VDC	5.5 A	8 mA	89 %	3670 µF
PQAE100-110S24W	40 ~ 160 VDC	24 VDC	3.5 A	8 mA	89 %	1460 µF
PQAE100-110S30W	40 ~ 160 VDC	30 VDC	2.8 A	8 mA	89 %	930 µF
PQAE100-110S48W	40 ~ 160 VDC	48 VDC	1.8 A	8 mA	89 %	380 µF

Part Number Structure

PQAE100 - 48	S	05	W - P	HS		
Series Name	Input Voltage	Output Quantity	Output Voltage	Input Range	CTRL and Pin Options	Heat-Sink and Mounting Hole Thread Options
	24: 8.5-36VDC	S: Single	3P3: 3.3VDC	4:1	□: Negative logic	□: None
	48: 16.5-75VDC		05: 5VDC		P: Positive logic	HS: H= 7G-0029A-F; 0.24"
	110: 40-160VDC		12: 12VDC			HS1: 7G-0030A-F; H=0.5"
			15: 15VDC			HS2: 7G-0031A-F; H=0.24"
			24: 24VDC			HS3: H= 7G-0032A-F; 0.5"
			30: 30VDC			TH: Through hole (no thread)
			48: 48VDC			

* The module can't equip Heat-sink with TH option.

POWERBOX Industrial Line
PQAE100W Series
 Up to 90W 4:1 Single Output
 High Performance
 DC/DC Converter

Fuse Consideration

This power module is not internally fused. An input line fuse must always be used. This encapsulated power module can be used in a wide variety of applications, ranging from simple stand-alone operation to an integrated part of sophisticated power architecture. To maximum flexibility, internal fusing is not included; however, to achieve maximum safety and system protection, always use an input line fuse. The input line fuse suggest as below:

Model	Fuse Rating (A)	Fuse Type
PQAE100-24S□□W	20	Fast-Acting
PQAE100-48S□□W	10	Fast-Acting
PQAE100-110S□□W	4	Slow-Blow

The table based on the information provided in this data sheet on inrush energy and maximum DC input current at low Vin.

Mechanical

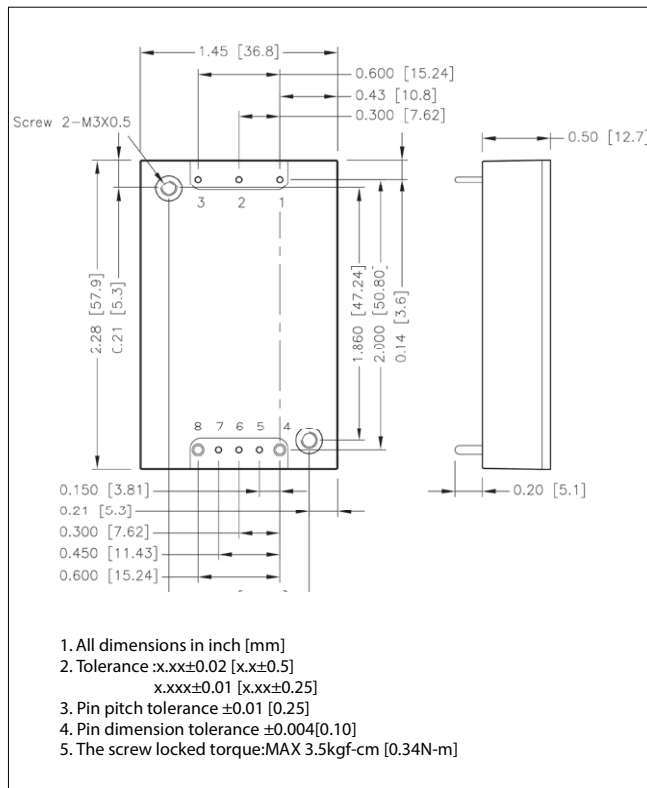

Pin Connection

Pin	Define	Diameter
1	- Vin	0.04 Inch
2	Ctrl	0.04 Inch
3	+ Vin	0.04 Inch
4	- Vout	0.06 Inch
5	- Sense	0.04 Inch
6	Trim	0.04 Inch
7	+ Sense	0.04 Inch
8	+ Vout	0.06 Inch

POWERBOX Industrial Line
 PQAE100W Series
 Up to 90W 4:1 Single Output
 High Performance
 DC/DC Converter

Recommended Pad Layout

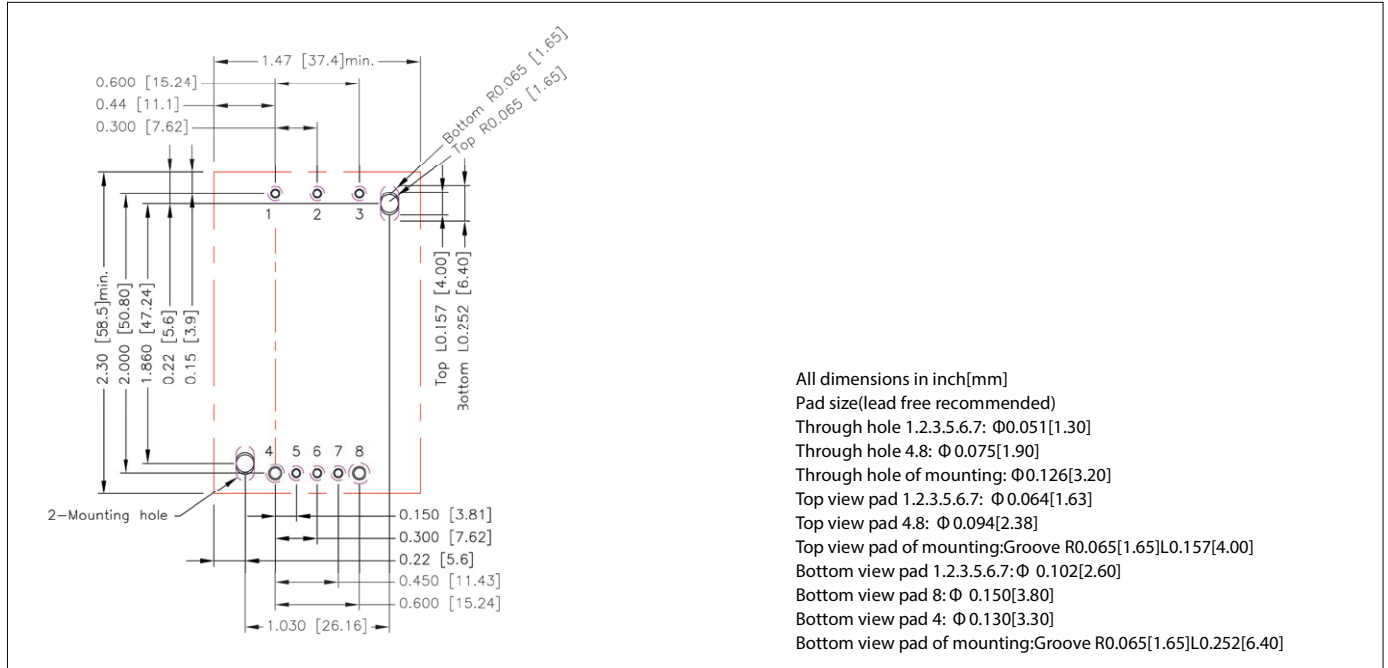

Thermal Considerations

The power module operates in a variety of thermal environments. However, sufficient cooling should be provided to help ensure reliable operation of the unit. Heat is removed by conduction, convection, and radiation to the surrounding Environment. Proper cooling can be verified by measuring the point as the figure below. The temperature at this location should not exceed 105°C. When Operating, adequate cooling must be provided to maintain the test point temperature at or below 105°C. Although the maximum point Temperature of the power modules is 105°C, you can limit this Temperature to a lower value for extremely high reliability. Thermal test condition with vertical direction by natural convection (20LFM). The iron base-plate dimension is 19" X 3.5" X 0.063" (The height is EIA standard 2U). The heat-sink is optional and P/N: 7G-0029B-F, 7G-0030B-F, 7G-0031B-F, 7G-0032B-F.

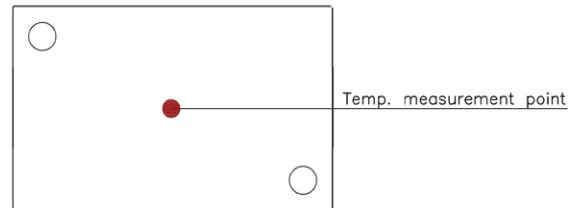

POWERBOX Industrial Line
 PQAE100W Series
 Up to 90W 4:1 Single Output
 High Performance
 DC/DC Converter

Heat-Sink Type Options

PQAE100-□□S□□W-HS
 7G-0029B-F

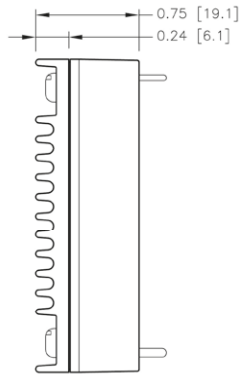

PQAE100-□□S□□W-HS1
 7G-0030B-F

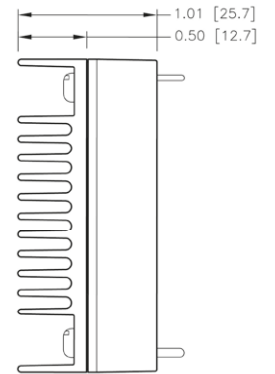

PQAE100-□□S□□W-HS2
 7G-0031B-F

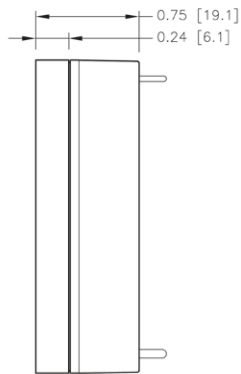
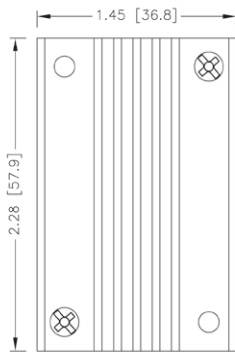

PQAE100-□□S□□W-HS3
 7G-0032B-F

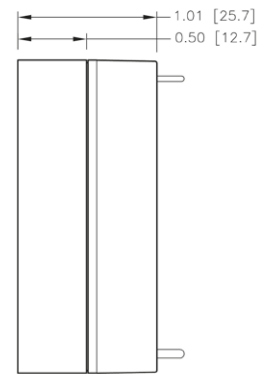
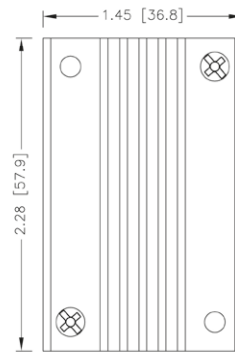

1. All dimensions in inch [mm]
2. Tolerance :x.xx±0.02 [x.x±0.5]

POWERBOX Industrial Line
PQAE100W Series
 Up to 90W 4:1 Single Output
 High Performance
 DC/DC Converter

Output Voltage Adjustment

Output voltage is adjustable for 10% trim up or -20% trim down of nominal output voltage by connecting an external resistor between the Trim pin and either the +Sense or -Sense pins. With an external resistor between the Trim and -Sense pin, the output voltage set point decreases. With an external resistor between the Trim and +Sense pin, the output voltage set point increases. Maximum output deviation is +10% inclusive of remote sense. The external TRIM resistor needs to be at least 1/8W of rated power.

Trim Up Equation

$$R_U = \left(\frac{5.11V_{OUT}(100 + \Delta\%)}{1.225\Delta\%} - \frac{511 + 10.22\Delta\%}{\%} \right) k\Omega$$

Trim Down Equation

$$R_D = \left(\frac{511}{\Delta\%} - 10.22 \right) k\Omega$$

External Output Trimming

Output can be externally trimmed by using the method shown below.

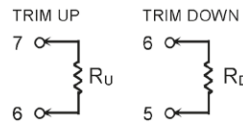

Trim Up

□□S3P3W

ΔV	(%)	1	2	3	4	5	6	7	8	9	10
Vout	(V)	3.333	3.366	3.399	3.432	3.465	3.498	3.531	3.564	3.597	3.630
R _U	(k Ω)	869.117	436.331	292.07	219.939	176.66	147.808	127.198	111.742	99.72	90.103

□□S05W

ΔV	(%)	1	2	3	4	5	6	7	8	9	10
Vout	(V)	5.05	5.10	5.15	5.20	5.25	5.30	5.35	5.40	5.45	5.50
R _U	(k Ω)	1585.35	797.994	535.542	404.316	325.58	273.09	235.596	207.476	185.605	168.109

□□S12W

ΔV	(%)	1	2	3	4	5	6	7	8	9	10
Vout	(V)	12.12	12.24	12.36	12.48	12.60	12.72	12.84	12.96	13.08	13.20
R _U	(k Ω)	4534.55	2287.19	1538.08	1163.52	938.78	788.956	681.939	601.676	539.25	489.309

□□S15W

ΔV	(%)	1	2	3	4	5	6	7	8	9	10
Vout	(V)	15.15	15.30	15.45	15.60	15.75	15.90	16.05	16.20	16.35	16.50
R _U	(k Ω)	5798.49	2925.42	1967.73	1488.89	1201.58	1010.04	873.229	770.619	690.812	626.966

□□S24W

ΔV	(%)	1	2	3	4	5	6	7	8	9	10
Vout	(V)	24.24	24.48	24.72	24.96	25.20	25.44	25.68	25.92	26.16	26.40
R _U	(k Ω)	9590.32	4840.11	3256.7	2465	1989.98	1673.3	1447.1	1277.45	1145.5	1039.94

□□S30W

ΔV	(%)	1	2	3	4	5	6	7	8	9	10
Vout	(V)	30.3	30.6	30.9	31.2	31.5	31.8	32.1	32.4	32.7	33
R _U	(k Ω)	12118.2	6116.57	4116.02	3115.74	2515.58	2115.47	1829.68	1615.33	1448.62	1315.25

□□S48W

ΔV	(%)	1	2	3	4	5	6	7	8	9	10
Vout	(V)	48.48	48.96	49.44	49.92	50.40	50.88	51.36	51.84	52.32	52.80
R _U	(k Ω)	19701.9	9945.94	6693.96	5067.97	4092.38	3441.99	2977.42	2628.99	2357.99	2141.19

Trim Down

□□S□□W

ΔV	(%)	1	2	3	4	5	6	7	8	9	10
R _D	(k Ω)	500.78	245.28	160.113	117.53	91.98	74.947	62.78	53.655	46.558	40.88

ΔV	(%)	11	12	13	14	15	16	17	18	19	20
R _D	(k Ω)	36.235	32.363	29.088	26.28	23.847	21.718	19.839	18.169	16.675	15.33

Specifications are subject to change without notice.