

POWERBOX

POWERBOX Industrial Line PMF20W Series 20W 4:1 Dual Output DC/DC Converter Manual

Table of Contents

Output specification	P2
Input specification	P3
General specification	P4
Environmental specifications	P4
EMC characteristic curves	P5
Input source impedance	P17
Output over current protection	P17
Output short circuitry protection	P17
Output over voltage protection	P17
Thermal considerations	P18
Heat sink considerations	P18
Remote on/off control	P19
EMS considerations	P20
Mechanical data	P20
Recommended pad layout	P20
Soldering considerations	P20
Packaging information	P21
Safety and installation instruction	P21
MTBF and reliability	P21
Recommended external EMI filter	P21

Introduction

PMF20W dual output DC/DC converters provide up to 20 watts of output power in an industry standard package and footprint. These units are specifically designed to meet the power needs of low profile. All models feature with 4:1 ultra wide input voltage of 9~36 VDC and 18~75 VDC, comprehensively protected against over-current, over-voltage and input under-voltage protection conditions, and adjustable output voltage.

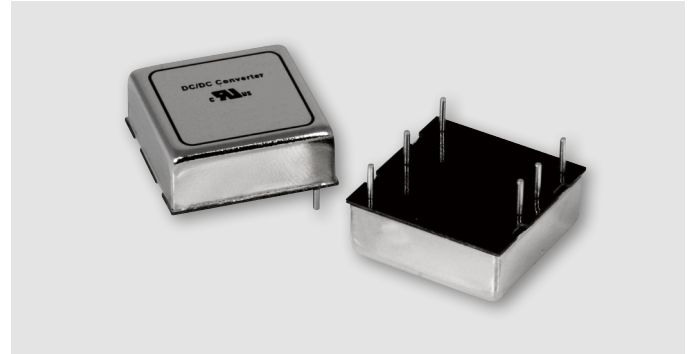

DC/DC Converter Features

20 Watts maximum output power
Ultra low quiescent current
Dual output current up to $\pm 833\text{mA}$
Industry standard pin-out
Small size and low profile: 1.0 x 1.0 x 0.39 inch
High efficiency up to 91%
4:1 wide input voltage range
Six-sided continuous shield
Meet EN55022 class A without external components
Fixed switching frequency
Input to output isolation 1600 VDC
No minimum load required
Input under voltage protection
Output over voltage protection
Output over current protection
Output short circuit protection
Remote on/off control
Adjustable output voltage
Compliant to RoHS II & REACH

POWERBOX Industrial Line
 PMF20W Series
 20W 4:1 Dual Output
 DC/DC Converter
 Manual

Output Specifications

Parameters	Model	Min	Typ	Max	Unit
Output voltage ($V_{in(nom)}$); full load; $T_a=25^\circ\text{C}$)	□□D12W	11.88	12	12.12	VDC
	□□D15W	14.85	15	15.15	VDC
	□□D24W	23.76	24	24.24	VDC
<i>Output regulation</i>					
Line ($V_{in(min)}$ to $V_{in(max)}$); full load)	All	-0.5		+0.5	%
Load (0% to 100% of full load)	All	-1.0		+1.0	%
Load (10% to 90% of full load)	All	-0.8		+0.8	%
<i>Output ripple and noise</i>					
Peak to peak (20MHz bandwidth) With a $1\mu\text{F}$ X7R MLCC and a $10\mu\text{F}$ T/C	□□D12W		100	125	mVp-p
	□□D15W				
	□□D24W				
With a $4.7\mu\text{F}/50\text{V}$ X7R MLCC	□□D12W				
Temperature coefficient	All	-0.02		+0.02	%/ $^\circ\text{C}$
Output voltage overshoot ($V_{in(min)}$ to $V_{in(max)}$ full load; $T_a=25^\circ\text{C}$)	All			5	% of V_{out}
<i>Dynamic load response ($V_{in(nom)}$); $T_a=25^\circ\text{C}$)</i>					
Load step change from 75% to 100% or 100 to 75% of full load					
Peak deviation	All		350		mV
Setting time ($V_o < 10\%$ peak deviation)	All		250		μs
Output current	□□D12W	0		± 833	mA
	□□D15W	0		± 667	mA
	□□D24W	0		± 417	mA
Output capacitance load	□□D12W			± 500	μF
	□□D15W			± 350	μF
	□□D24W			± 100	μF
Output over voltage protection (voltage clamped)	□□D12W	13.5		19.6	VDC
	□□D15W	16.8		20.5	VDC
	□□D24W	29.1		32.5	VDC
Output over current protection	All		150		% of FL
Output short circuit protection	All	Continuous, automatic recovery			

POWERBOX Industrial Line
 PMF20W Series
 20W 4:1 Dual Output
 DC/DC Converter
 Manual

Input Specifications

Parameters	Model	Min	Typ	Max	Unit
<i>Operating input voltage</i>					
Continuous	24D□□W	9	24	36	VDC
	48D□□W	18	48	75	VDC
Transient (1sec, max)	24D□□W			50	VDC
	48D□□W			100	VDC
Input standby current (Typ. value at Vin(nom); no load)	24D12W		6		mA
	24D15W		6		mA
	24D24W		12		mA
	48D12W		4		mA
	48D15W		4		mA
	48D24W		10		mA
Under voltage lockout turn-on threshold	24S□□W			9	VDC
	48S□□W			18	VDC
Under voltage lockout turn-off threshold	24S□□W		8		VDC
	48S□□W		16		VDC
Input reflected ripple current (5 to 20MHz, 12μH source impedance)	All		30		mA _{p-p}
Start up time (Vin(nom) and constant resistive load)					
Power up	All			30	ms
Remote on/off	All			30	ms
<i>Remote ON/OFF control (The Ctrl pin voltage is referred to -INPUT)</i>					
Positive logic (option)					
On/Off pin high voltage (remote ON)	□□D□□W-A	Open or 3 ~ 15VDC			
On/Off pin low voltage (remote OFF)		Short or 0 ~ 1.2VDC			
Negative logic (standard)					
On/Off pin low voltage (remote ON)	□□D□□W	Short or 0 ~ 1.2VDC			
On/Off pin high Vvltage (remote OFF)		Open or 3 ~ 15VDC			
Input current of remote control pin		-0.5		1.0	mA
Remote off state input current			2.0		mA

General Specifications

Parameters	Model	Min	Typ	Max	Unit
Efficiency (Vin(nom), full load; Ta=25°C)	24D12W		89		%
	24D15W		90		%
	24D24W		91		%
	48D12W		89		%
	48D15W		90		%
	48D24W		91		%
<i>Isolation voltage (1 minute)</i>					
Input to output	All	1600			VDC
Input to case, output to case	All	1000			VDC
Isolation resistance (500VDC)	All	1			GΩ
Isolation capacitance	All			1500	pF
Switching frequency	All	297	330	363	kHz
Weight	All		15		g
MTBF MIL-HDBK-217F	All		1.469 x 10 ⁶		hours
Safety approvals	All	UL60950-1, EN60950-1, IEC60950-1			
Case material	All	Nickel-coated copper			
Base material	All	FR4 PCB			
Potting material	All	Silicone (UL94-V0)			

Environmental Specifications

Parameters	Model	Min	Typ	Max	Unit
<i>Operating case temperature</i>					
Without derating	All	-40		60	°C
With derating	All	60		101	°C
Storage temperature	All	-55		125	°C
Max case temperature	All			105	°C
<i>Thermal impedance (natural convection with vertical direction)</i>					
Without heat-sink	All		17.6		°C/W
With heat-sink	All		14.8		°C/W
Relative humidity	All	5		95	% RH
Thermal shock	All	MIL-STD-810F			
Vibration	All	MIL-STD-810F			

EMC Characteristics

Parameters	Standard	Condition	Level
EMI	EN55022	Module stand-alone	Class A
		With external input filter	Class B
ESD	EN61000-4-2	Air ±8kV	Perf. Criteria A
		Contact ±6kV	
Radiated Immunity	EN61000-4-3	10V/m	Perf. Criteria A
Fast transient	EN61000-4-4	±2kV	Perf. Criteria A
Surge	EN61000-4-5	±2kV	Perf. Criteria A
Conducted immunity	EN61000-4-6	10V r.m.s	Perf. Criteria A
Power frequency magnetic field	EN61000-4-8	100A/m continuous; 1000A/m 1 second	Perf. Criteria A

POWERBOX Industrial Line
 PMF20W Series
 20W 4:1 Dual Output
 DC/DC Converter
 Manual

All test conditions are at 25°C. The figures are identical for PMF20-24D12W

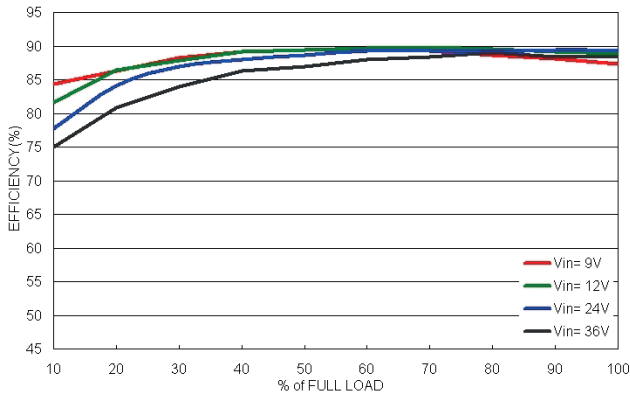

Efficiency versus Output Current

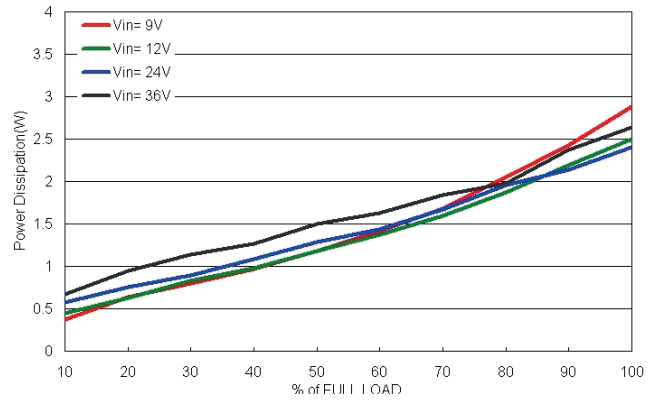

Power Dissipation versus Output Current

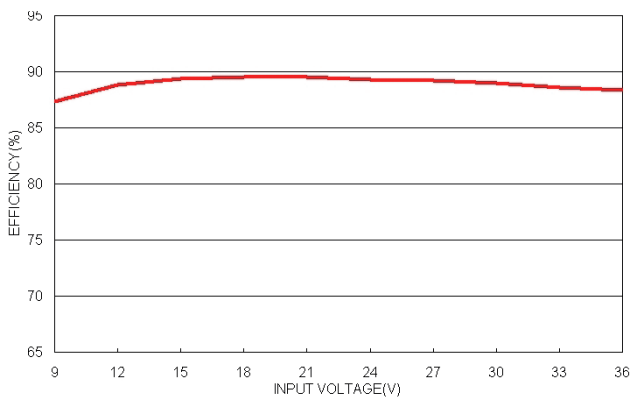

Efficiency versus Input Voltage Full Load

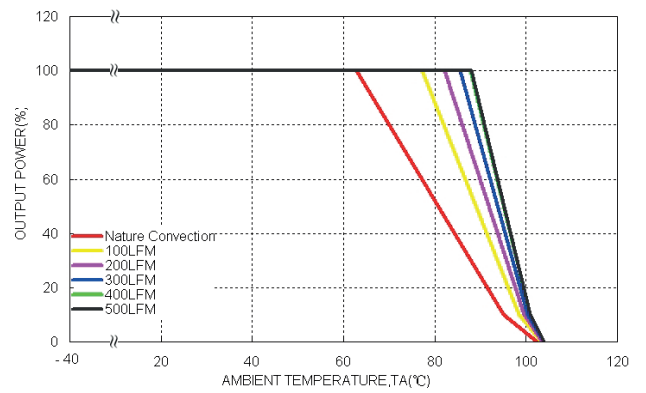

Derating Output Current versus Ambient Temperature and Airflow Vin(nom)

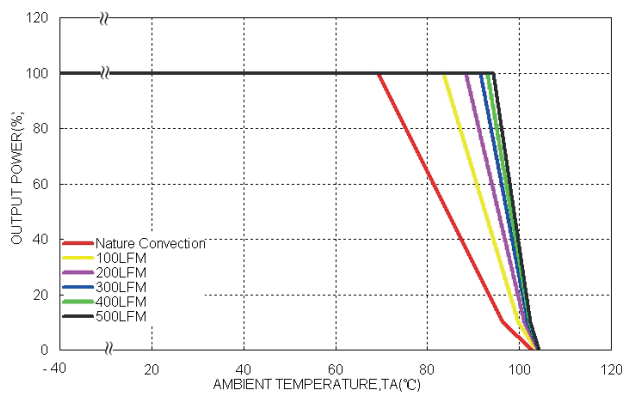

Derating Output Current versus Ambient Temperature with Heat-sink and Airflow, Vin(nom)

POWERBOX Industrial Line
 PMF20W Series
 20W 4:1 Dual Output
 DC/DC Converter
 Manual

All test conditions are at 25°C. The figures are identical for PMF20-24D12W

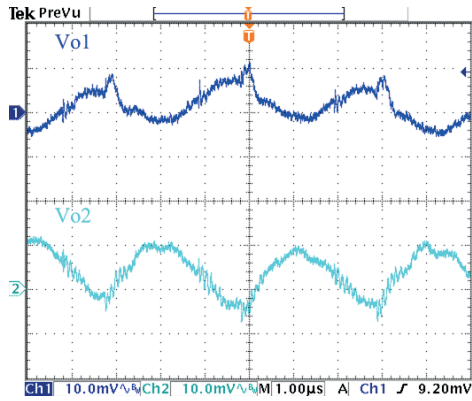

Typical Output Ripple and Noise.
 $V_{in}(\text{nom})$; Full Load

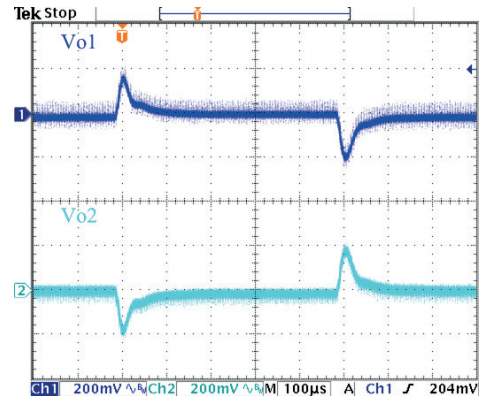

Transient Response to Dynamic Load Change from
 100% to 75% to 100% of Full Load; $V_{in}(\text{nom})$

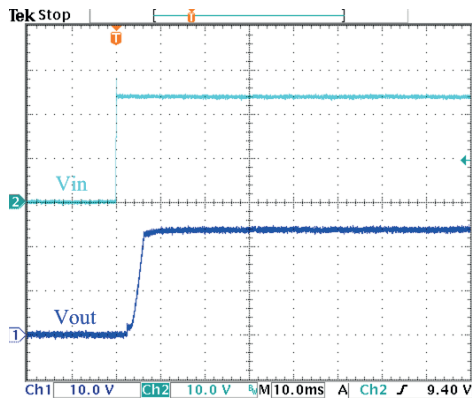

Typical Input Start-Up and Output Rise Characteristic
 $V_{in}(\text{nom})$; Full Load

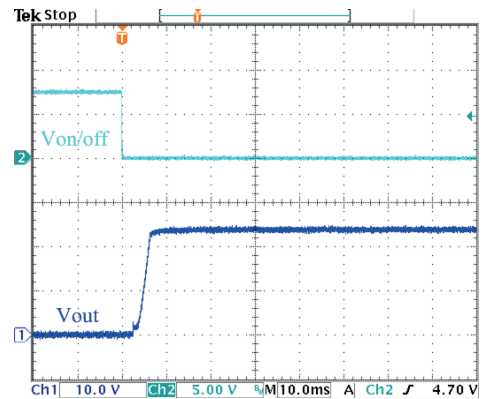

Using ON/OFF Voltage Start-Up and Output Rise Characteristic
 $V_{in}(\text{nom})$; Full Load

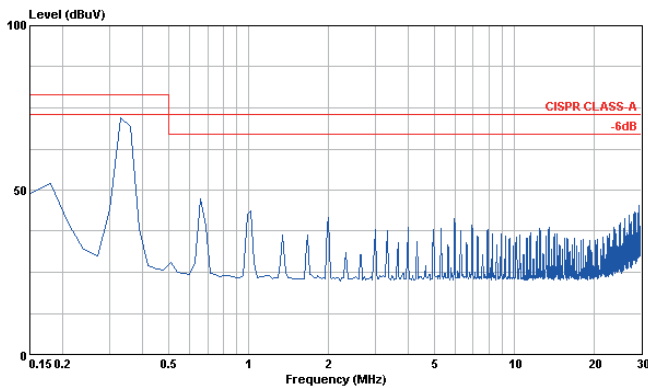

Conduction Emission of EN55022 Class A
 $V_{in}(\text{nom})$; Full Load

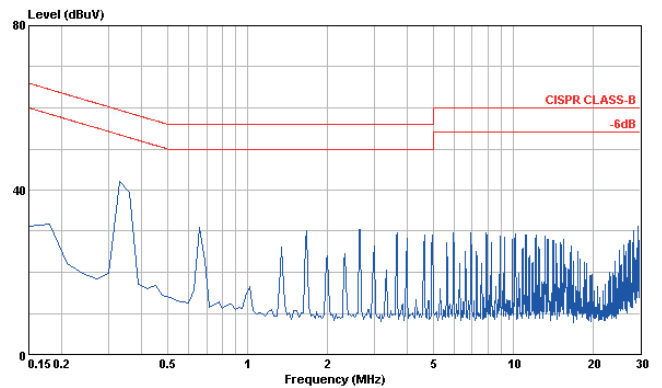

Conduction Emission of EN55022 Class B
 $V_{in}(\text{nom})$; Full Load

POWERBOX Industrial Line
 PMF20W Series
 20W 4:1 Dual Output
 DC/DC Converter
 Manual

All test conditions are at 25°C. The figures are identical for PMF20-24D15W

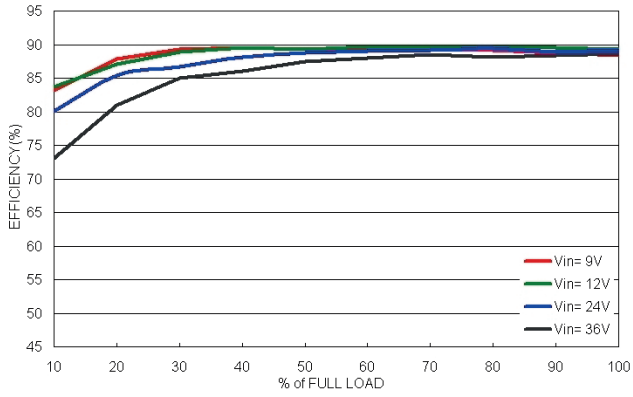

Efficiency versus Output Current

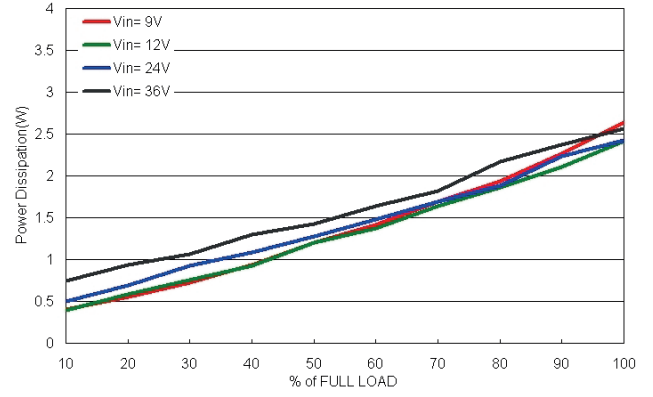

Power Dissipation versus Output Current

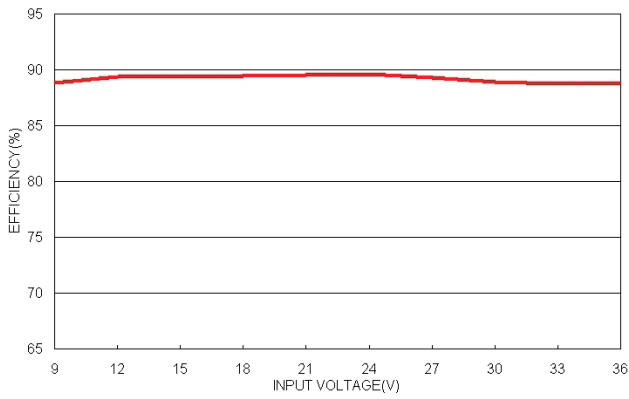

Efficiency versus Input Voltage Full Load

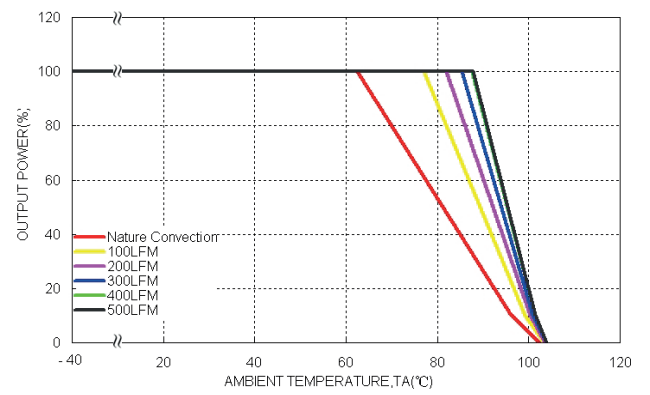

Derating Output Current versus Ambient Temperature and Airflow Vin(nom)

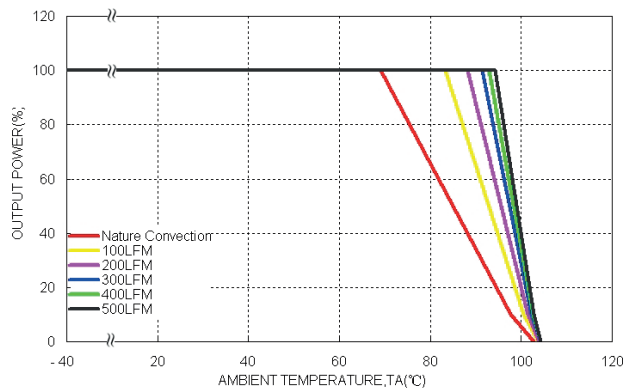

Derating Output Current versus Ambient Temperature with Heat-sink and Airflow, Vin(nom)

POWERBOX Industrial Line
 PMF20W Series
 20W 4:1 Dual Output
 DC/DC Converter
 Manual

All test conditions are at 25°C. The figures are identical for PMF20-24D15W

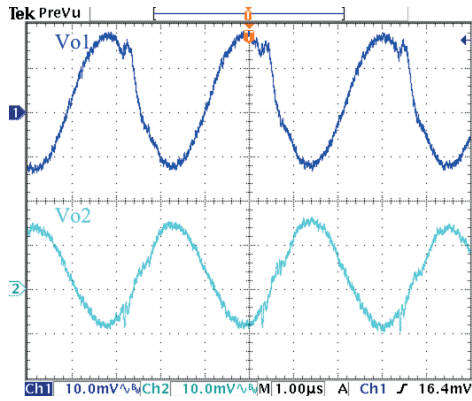

Typical Output Ripple and Noise.
 Vin(nom); Full Load

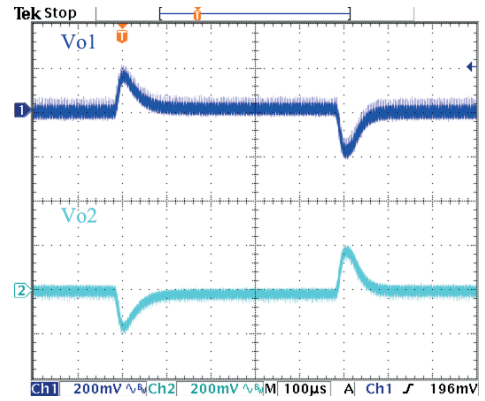

Transient Response to Dynamic Load Change from
 100% to 75% to 100% of Full Load; Vin(nom)

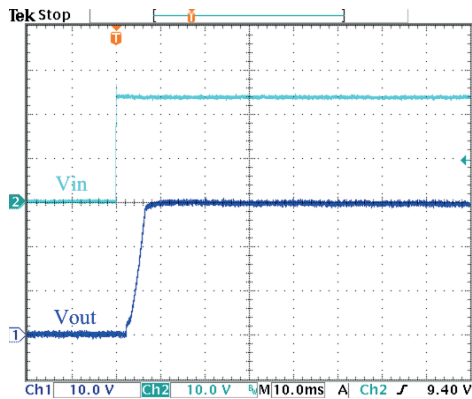

Typical Input Start-Up and Output Rise Characteristic
 Vin(nom); Full Load

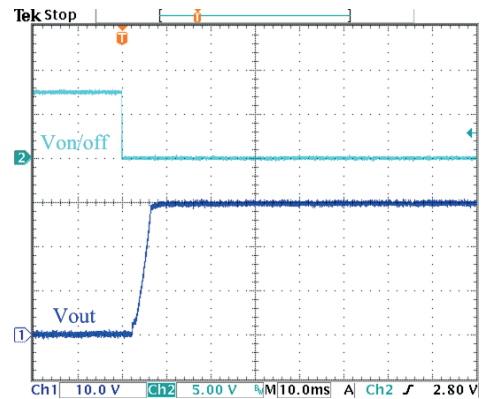

Using ON/OFF Voltage Start-Up and Output Rise Characteristic
 Vin(nom); Full Load

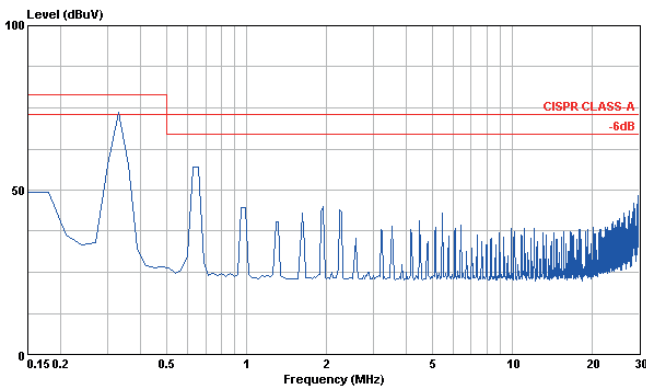

Conduction Emission of EN55022 Class A
 Vin(nom); Full Load

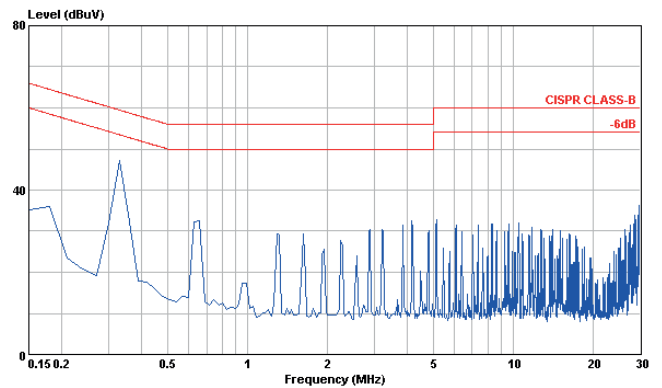

Conduction Emission of EN55022 Class B
 Vin(nom); Full Load

POWERBOX Industrial Line
 PMF20W Series
 20W 4:1 Dual Output
 DC/DC Converter
 Manual

All test conditions are at 25°C. The figures are identical for PMF20-24D24W

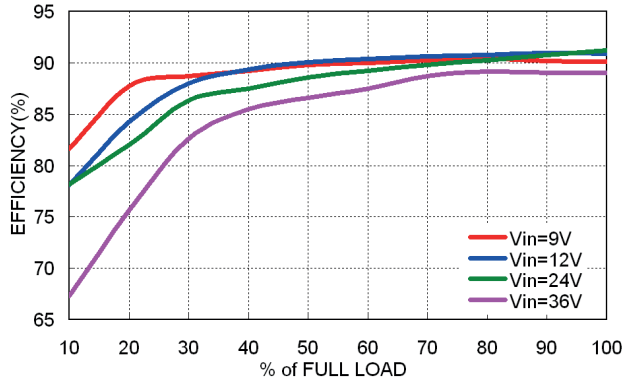

Efficiency versus Output Current

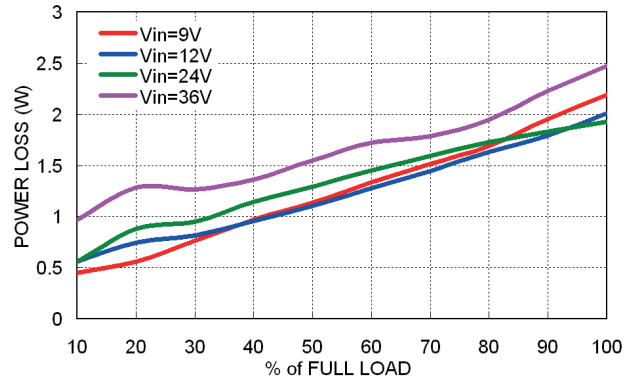

Power Dissipation versus Output Current

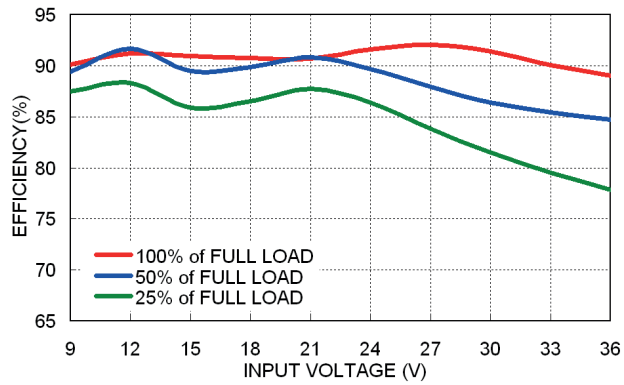

Efficiency versus Input Voltage Full Load

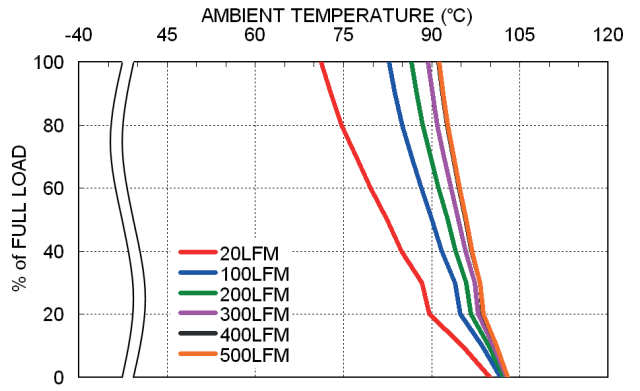

Derating Output Current versus Ambient Temperature and Airflow Vin(nom)

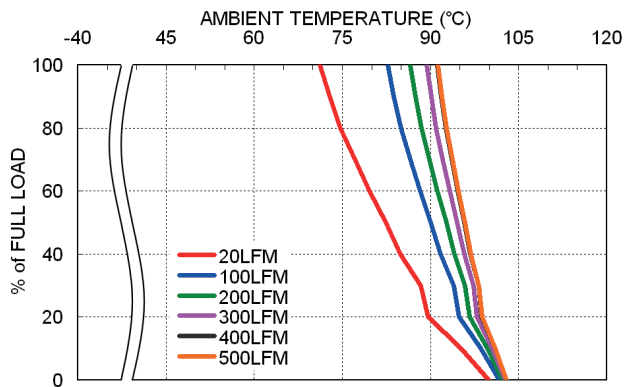

Derating Output Current versus Ambient Temperature with Heat-sink and Airflow, Vin(nom)

All test conditions are at 25°C. The figures are identical for PMF20-24D24W

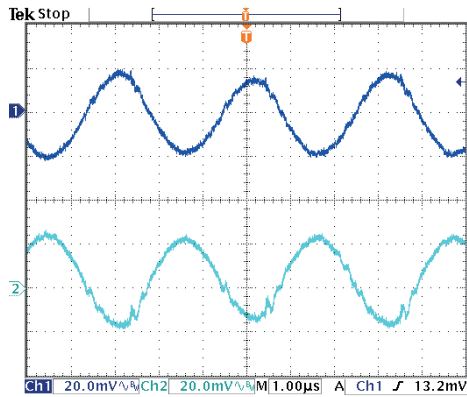

Typical Output Ripple and Noise.
 $V_{in}(nom)$; Full Load

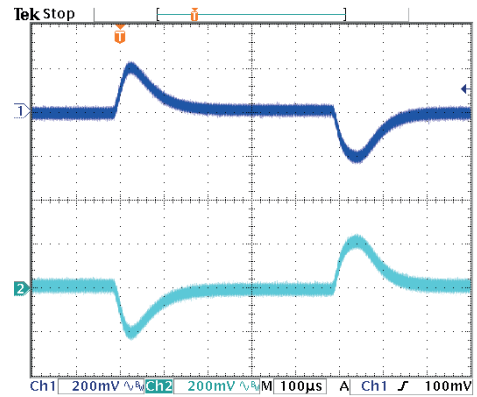

Transient Response to Dynamic Load Change from
 100% to 75% to 100% of Full Load; $V_{in}(nom)$

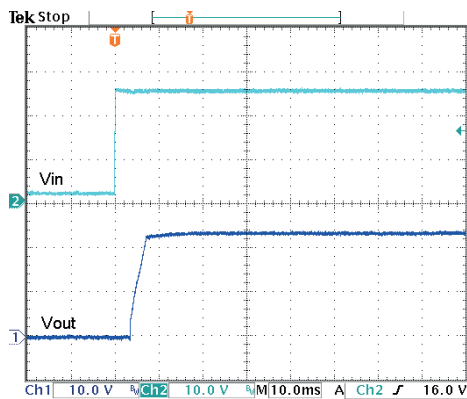

Typical Input Start-Up and Output Rise Characteristic
 $V_{in}(nom)$; Full Load

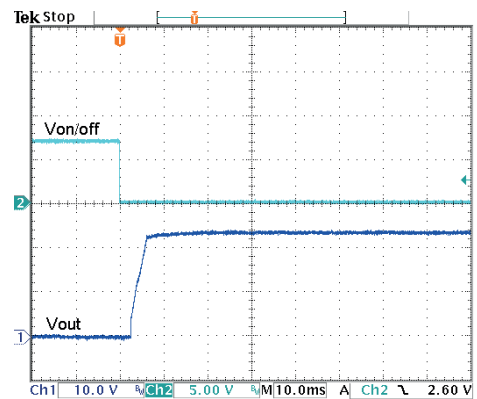

Using ON/OFF Voltage Start-Up and Output Rise Characteristic
 $V_{in}(nom)$; Full Load

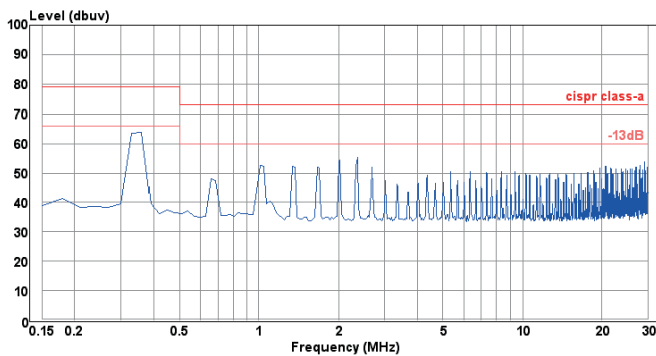

Conduction Emission of EN55022 Class A
 $V_{in}(nom)$; Full Load

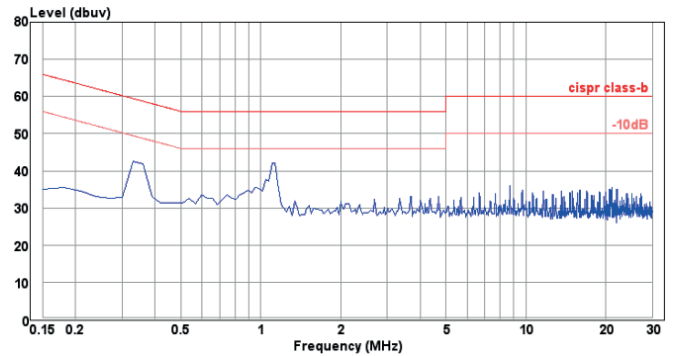

Conduction Emission of EN55022 Class B
 $V_{in}(nom)$; Full Load

POWERBOX Industrial Line
 PMF20W Series
 20W 4:1 Dual Output
 DC/DC Converter
 Manual

All test conditions are at 25°C. The figures are identical for PMF20-48D12W

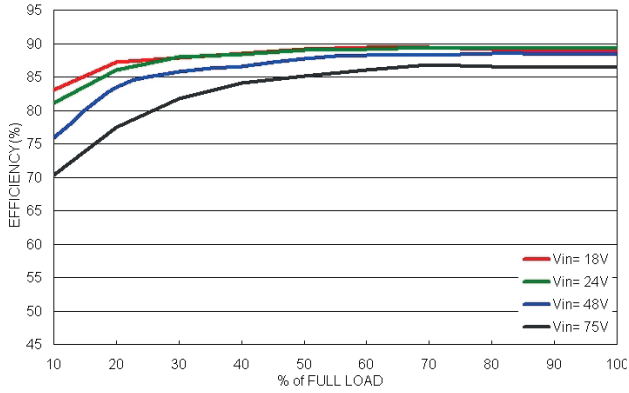

Efficiency versus Output Current

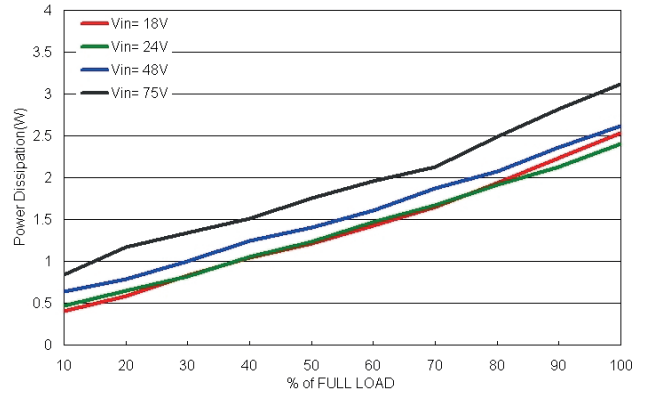

Power Dissipation versus Output Current

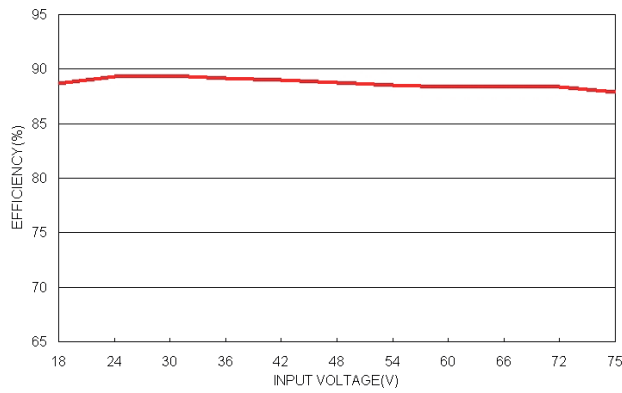

Efficiency versus Input Voltage Full Load

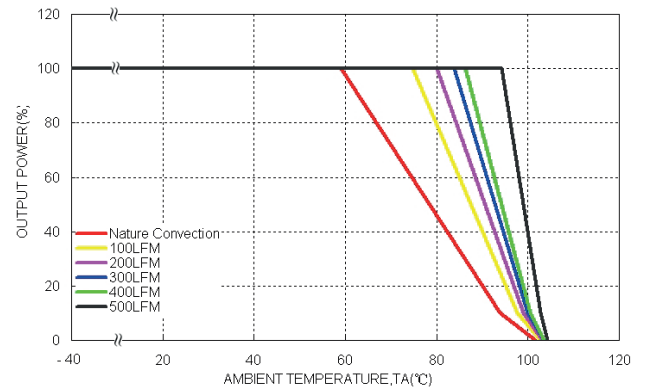

Derating Output Current versus Ambient Temperature and Airflow Vin(nom)

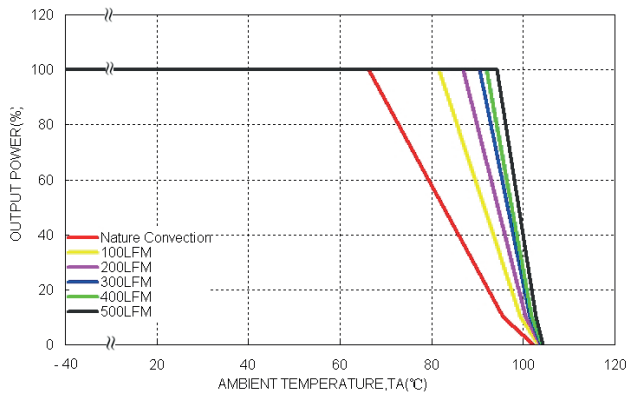

Derating Output Current versus Ambient Temperature with Heat-sink and Airflow, Vin(nom)

All test conditions are at 25°C. The figures are identical for PMF20-48D12W

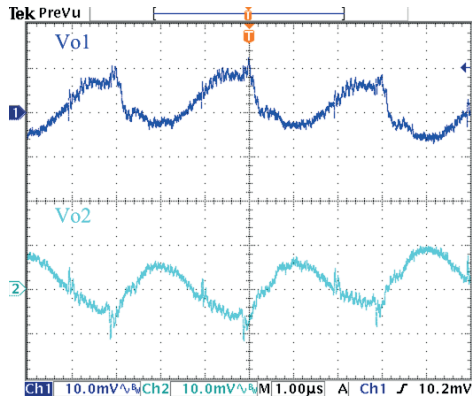

Typical Output Ripple and Noise.
 $V_{in}(nom)$; Full Load

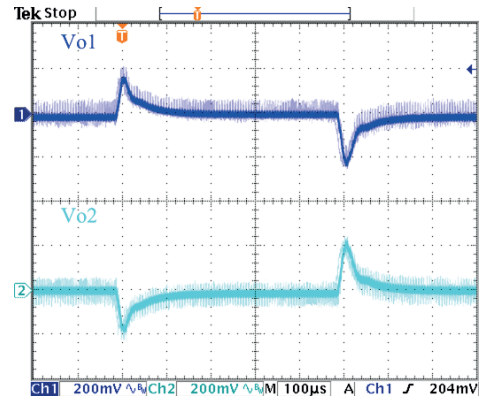

Transient Response to Dynamic Load Change from
 100% to 75% to 100% of Full Load; $V_{in}(nom)$

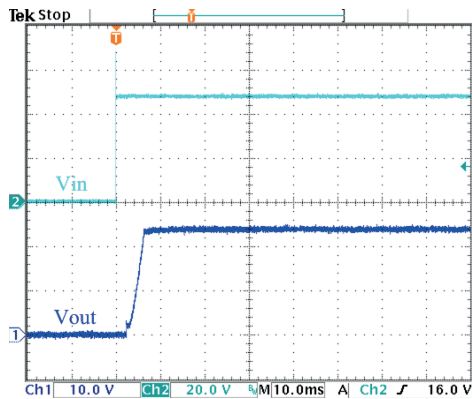

Typical Input Start-Up and Output Rise Characteristic
 $V_{in}(nom)$; Full Load

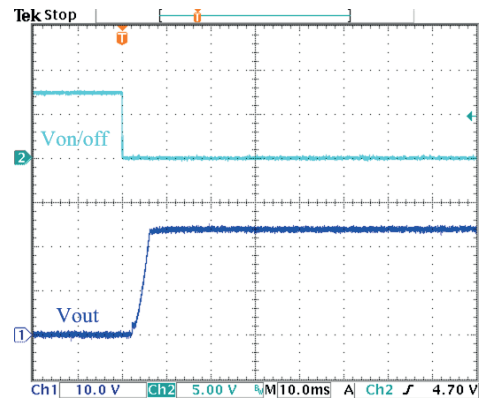

Using ON/OFF Voltage Start-Up and Output Rise Characteristic
 $V_{in}(nom)$; Full Load

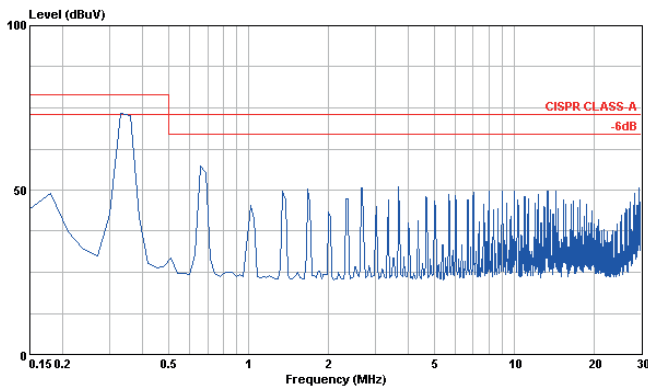

Conduction Emission of EN55022 Class A
 $V_{in}(nom)$; Full Load

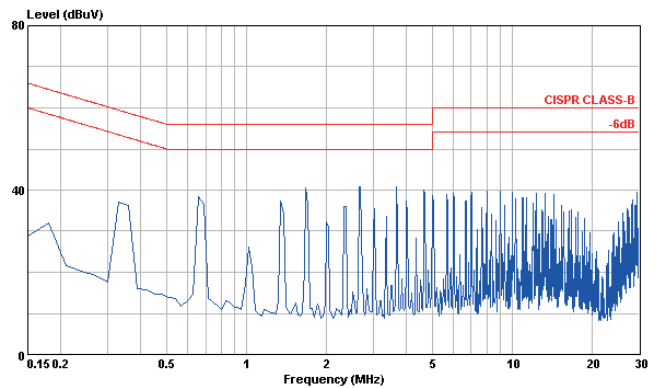

Conduction Emission of EN55022 Class B
 $V_{in}(nom)$; Full Load

POWERBOX Industrial Line
 PMF20W Series
 20W 4:1 Dual Output
 DC/DC Converter
 Manual

All test conditions are at 25°C. The figures are identical for PMF20-48D15W

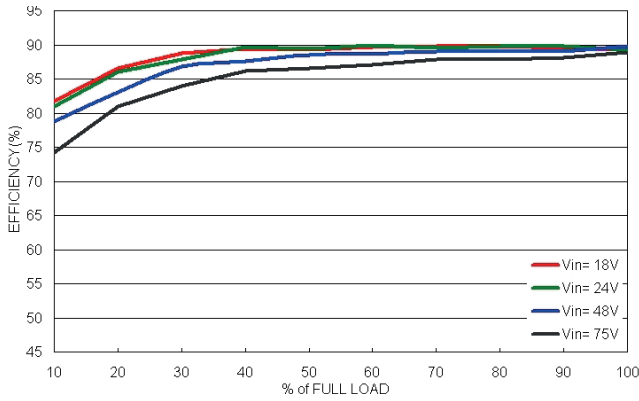

Efficiency versus Output Current

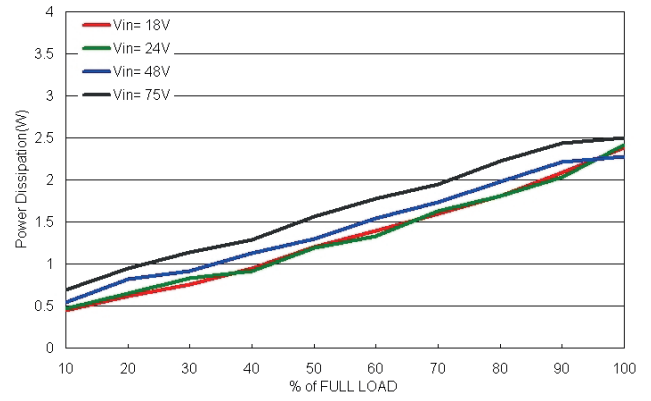

Power Dissipation versus Output Current

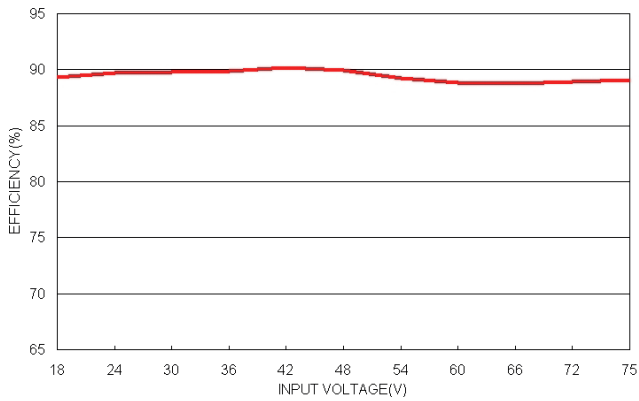

Efficiency versus Input Voltage Full Load

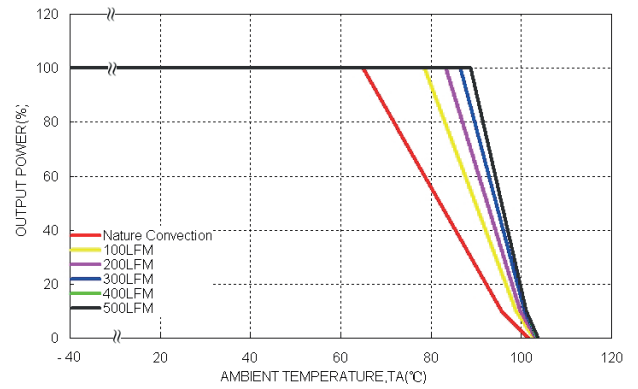

Derating Output Current versus Ambient Temperature and Airflow Vin(nom)

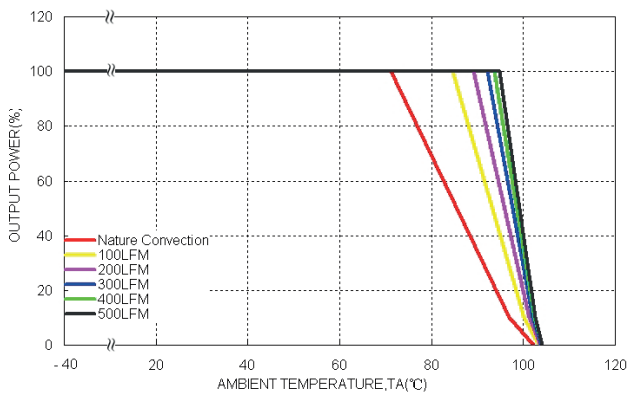

Derating Output Current versus Ambient Temperature with Heat-sink and Airflow, Vin(nom)

All test conditions are at 25°C. The figures are identical for PMF20-48D15W

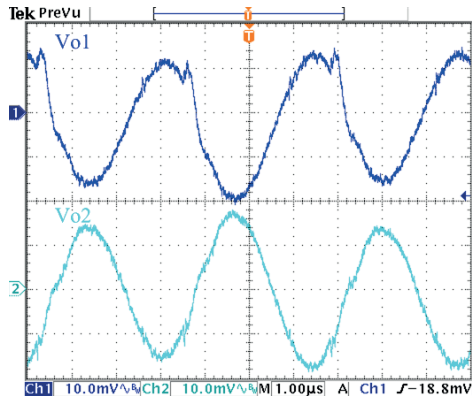

Typical Output Ripple and Noise.
 $V_{in}(nom)$; Full Load

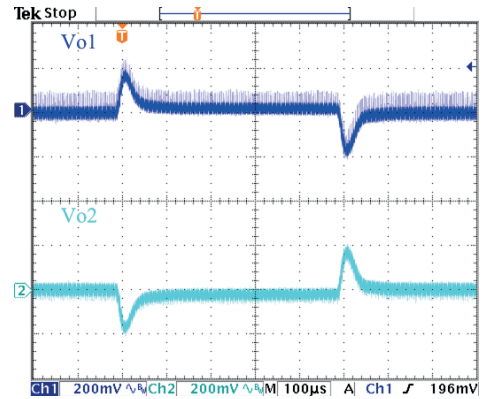

Transient Response to Dynamic Load Change from
 100% to 75% to 100% of Full Load; $V_{in}(nom)$

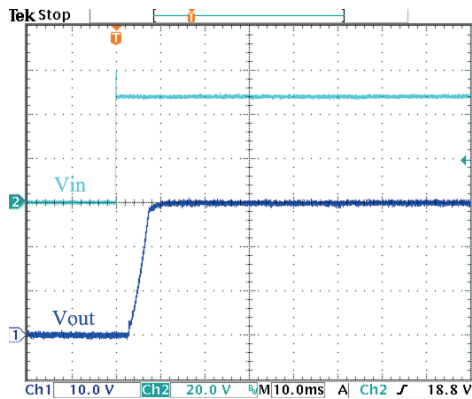

Typical Input Start-Up and Output Rise Characteristic
 $V_{in}(nom)$; Full Load

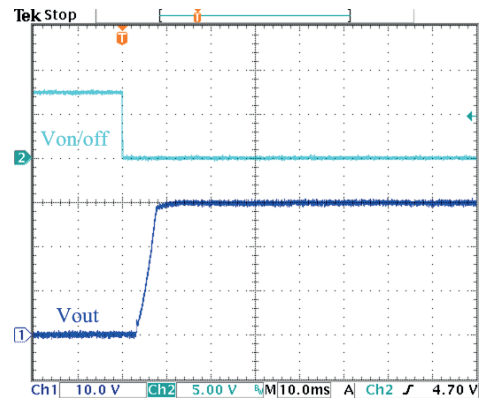

Using ON/OFF Voltage Start-Up and Output Rise Characteristic
 $V_{in}(nom)$; Full Load

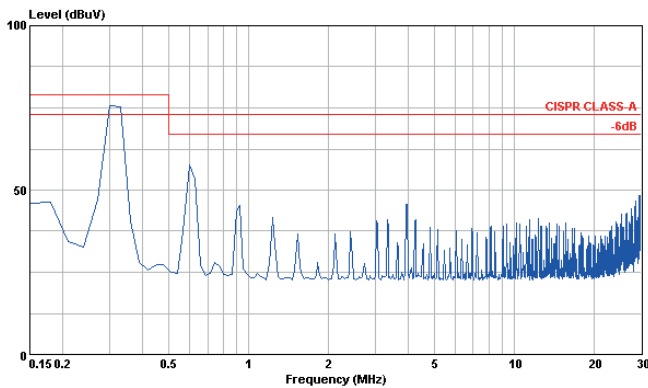

Conduction Emission of EN55022 Class A
 $V_{in}(nom)$; Full Load

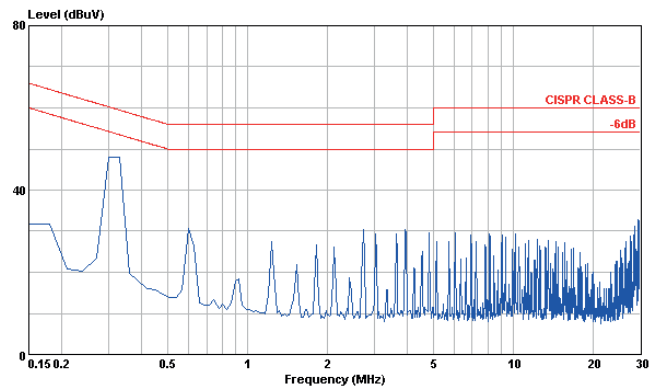

Conduction Emission of EN55022 Class B
 $V_{in}(nom)$; Full Load

POWERBOX Industrial Line
 PMF20W Series
 20W 4:1 Dual Output
 DC/DC Converter
 Manual

All test conditions are at 25°C. The figures are identical for PMF20-48D24W

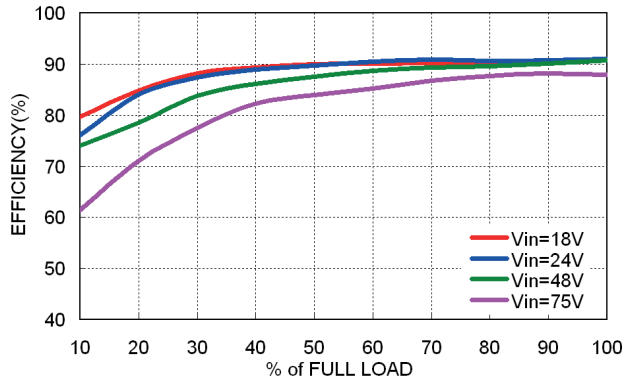

Efficiency versus Output Current

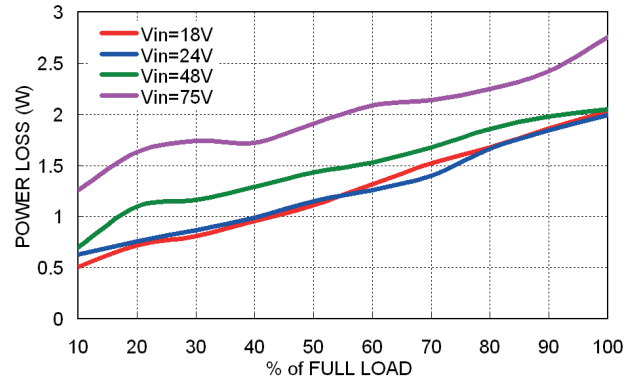

Power Dissipation versus Output Current

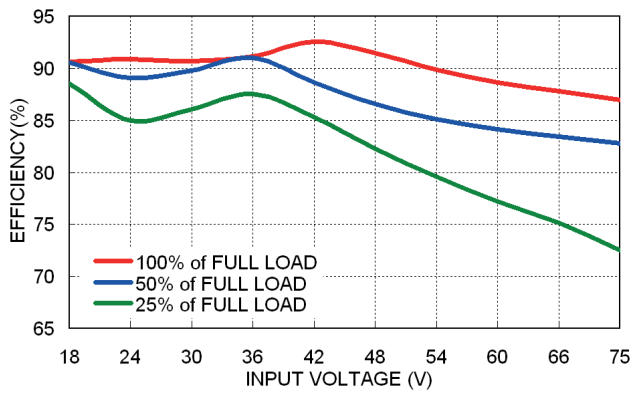

Efficiency versus Input Voltage Full Load

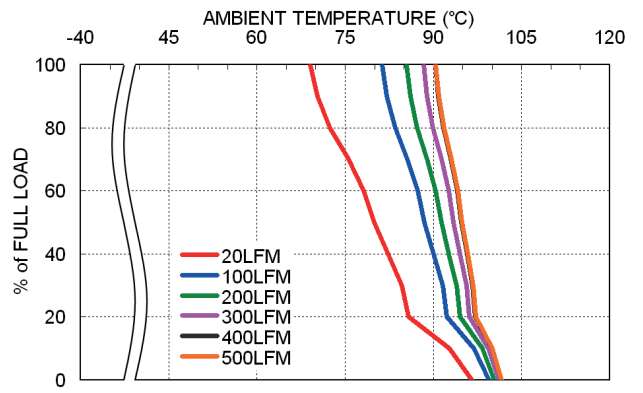

Derating Output Current versus Ambient Temperature and Airflow Vin(nom)

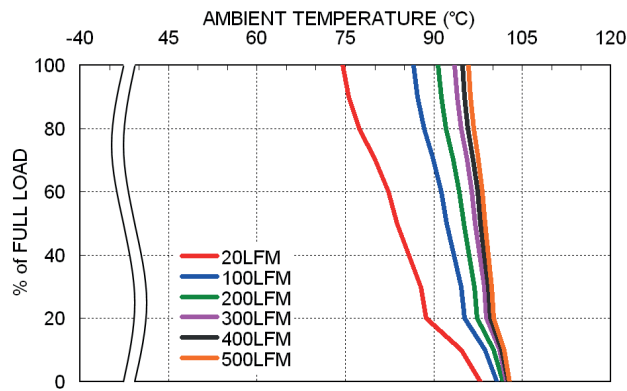

Derating Output Current versus Ambient Temperature with Heat-sink and Airflow, Vin(nom)

All test conditions are at 25°C. The figures are identical for PMF20-48D24W

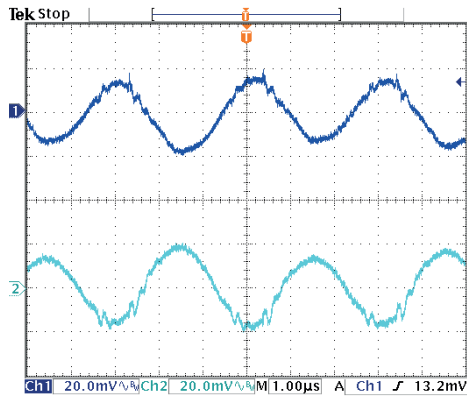

Typical Output Ripple and Noise.
 $V_{in}(nom)$; Full Load

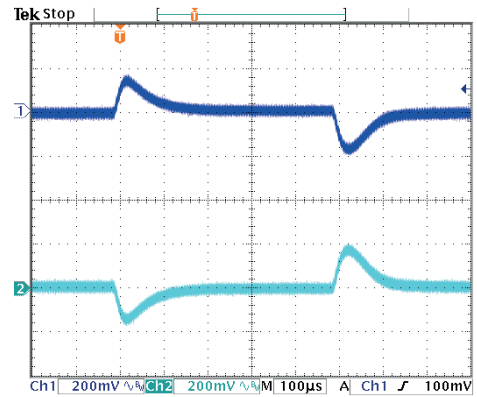

Transient Response to Dynamic Load Change from
 100% to 75% to 100% of Full Load; $V_{in}(nom)$

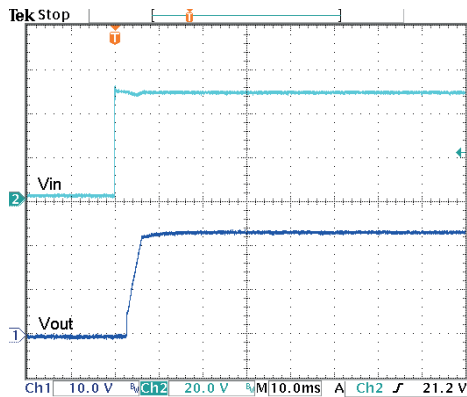

Typical Input Start-Up and Output Rise Characteristic
 $V_{in}(nom)$; Full Load

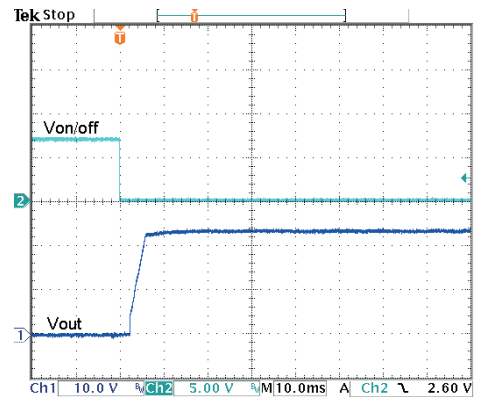

Using ON/OFF Voltage Start-Up and Output Rise Characteristic
 $V_{in}(nom)$; Full Load

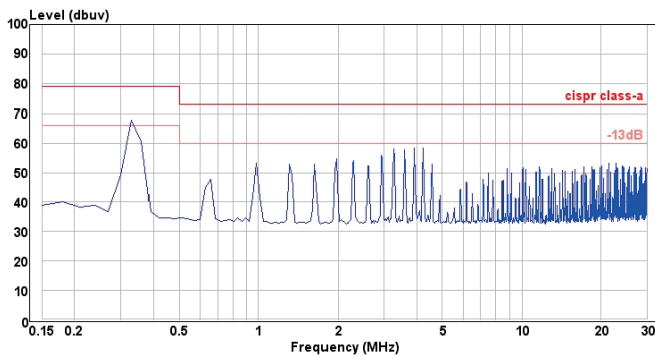

Conduction Emission of EN55022 Class A
 $V_{in}(nom)$; Full Load

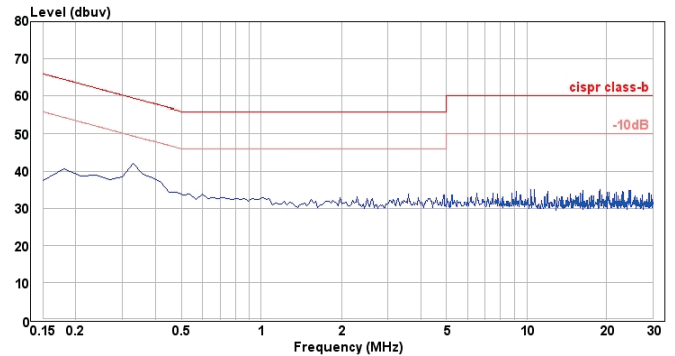

Conduction Emission of EN55022 Class B
 $V_{in}(nom)$; Full Load

Input Source Impedance

The power module should be connected to a low impedance input source. Highly inductive source impedance can affect the stability of the power module. Install CSIM and LSIM to simulate the impedance of power source. External input capacitors CFILTER serve primarily as energy-storage elements, minimizing line voltage variations caused by transient IR drops in conductors from backplane to the DC/DC. The capacitor must as close as possible to the input terminals of the power module for lower impedance. For the input reflected-ripple current measurement configuration is shown as below:

Input Reflected Ripple Current Measurement Setup

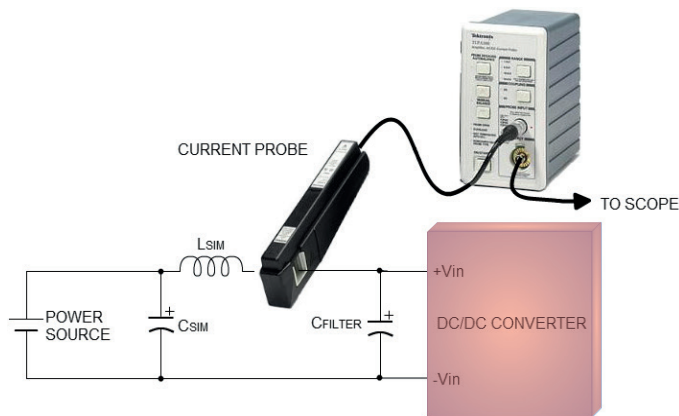

PMF20-□□S□□W

Component	Value	Voltage	Reference
LSIM	12 μ H	----	Inductor
CSIM CFILTER	10 μ F	100V	Nippon chemi-con KY-series

Output Over Current Protection

When excessive output currents occur in the system, circuit protection is required on all power supplies. Normally, overload current is maintained at approximately 150 percent of rated current for PMF20W dual output series. Hiccup-mode is a method of operation in a power supply whose purpose is to protect the power supply from being damaged during an over-current fault condition. It also enables the power supply to restart when the fault is removed. There are other ways of protecting the power supply when it is over-loaded, such as the maximum current limiting or current fold-back methods. One of the problems resulting from over current is that excessive heat may be generated in power devices; especially MOSFET and Schottky diodes and the temperature of those devices may exceed their specified limits. A protection mechanism has to be used to prevent those power devices from being damaged.

The operation of hiccup is as follows. When the current sense circuit sees an over-current event, the controller shuts off the power supply for a given time and then tries to start up the power supply again. If the over-load condition has been removed, the power supply will start up and operate normally; otherwise, the controller will see another over-current event and shut off the power supply again, repeating the previous cycle. Hiccup operation has none of the drawbacks of the other two protection methods, although its circuit is more complicated because it requires a timing circuit. The excess heat due to overload lasts for only a short duration in the hiccup cycle, hence the junction temperature of the power devices is much lower.

The hiccup operation can be done in various ways. For example, one can start hiccup operation any time an over-current event is detected; or prohibit hiccup during a designated start-up is usually larger than during normal operation and it is easier for an over-current event is detected; or prohibit hiccup during a designated start-up interval (usually a few milliseconds). The reason for the latter operation is that during start-up, the power supply needs to provide extra current to charge up the output capacitor. Thus the current demand during start-up is usually larger than during normal operation and it is easier for an over-current event to occur. If the power supply starts to hiccup once there is an over-current, it might never start up successfully. Hiccup mode protection will give the best protection for a power supply against over current situations, since it will limit the average current to the load at a low level, so reducing power dissipation and case temperature in the power devices.

Output Short Circuitry Protection

Continuous, auto-recovery mode. During short circuit, converter still shut down. The average current during this condition will be very low and the device can be safety in this condition.

Output Over Voltage Protection

The output over-voltage protection consists of Zener diode that monitors the output voltage on the feedback loop. If the voltage on the output terminals exceeds the over-voltage protection threshold, then the Zener diode will send a current signal to the control IC to limiting the output voltage.

Thermal Consideration

The power module operates in a variety of thermal environments. However, sufficient cooling should be provided to help ensure reliable operation of the unit. Heat is removed by conduction, convection, and radiation to the surrounding environment. Proper cooling can be verified by measuring the point as the figure below. The temperature at this location should not exceed 105°C. When operating, adequate cooling must be provided to maintain the test point temperature at or below 105°C. Although the maximum point temperature of the power modules is 105°C, you can limit this temperature to a lower value for extremely high reliability.

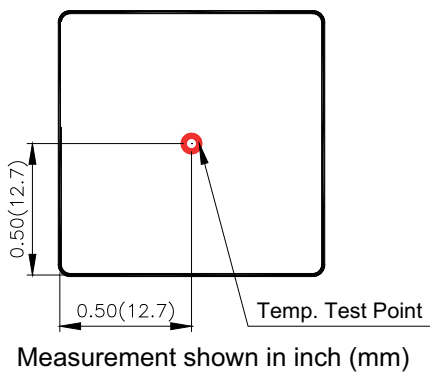

Heat-Sink Considerations

Equip heat-sink for lower temperature and higher reliability of the module. There are two types for choosing.

Suffix – HC : Heat-sink + Clamp

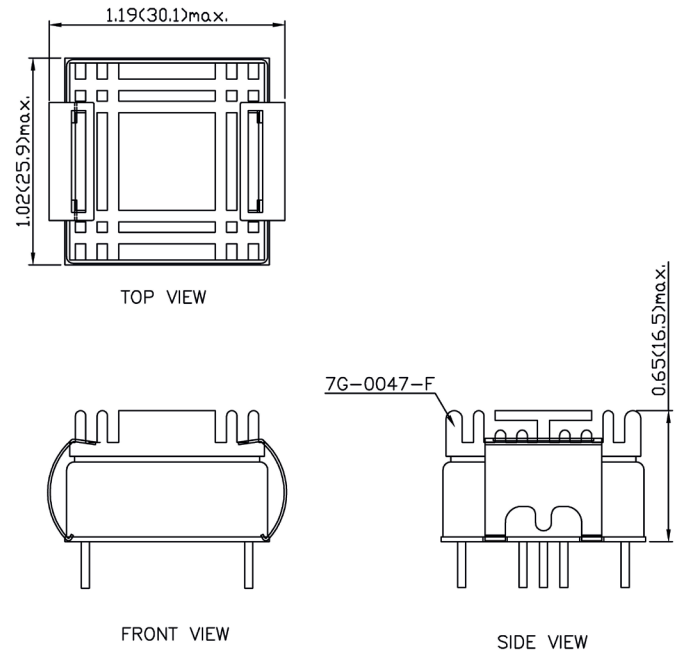

Suffix –HS : Heat-sink

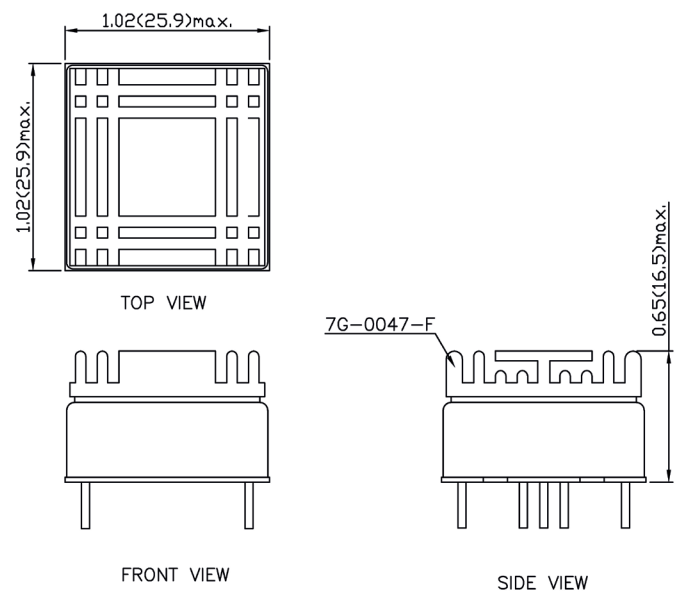

All dimensions in inch (mm)

Remote On/Off Control

The Ctrl Pin is controlled DC/DC power module to turn on and off, the user must use a switch to control the logic voltage high or low level of the pin referenced to -Vin. The switch can be open collector transistor, FET and Photo-Coupler. The switch must be capable of sinking up to 1 mA at low-level logic voltage. High-level logic of the Ctrl pin signal maximum voltage is allowable leakage current of the switch at 12V is 0.5 mA.

Remote ON/OFF Implementation

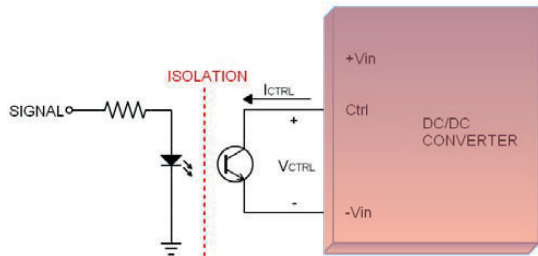

Isolated-Closure Remote ON/OFF

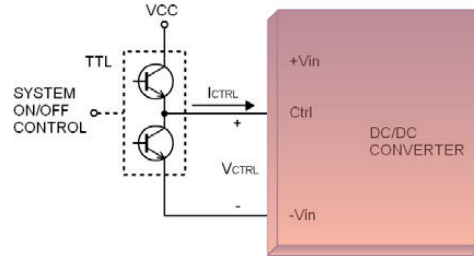

Level Control Using TTL Output

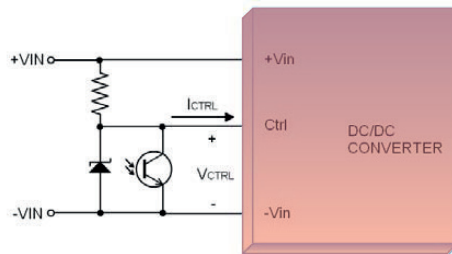

Level Control Using Line Voltage

There are two remote control options available, positive logic and negative logic.

a. The positive logic structure turned on of the DC/DC module when the Ctrl pin is at high-level logic and low-level logic is turned off it.

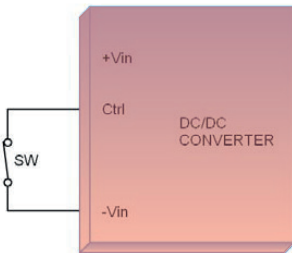

When PMF20W module is turned off at Low-level logic

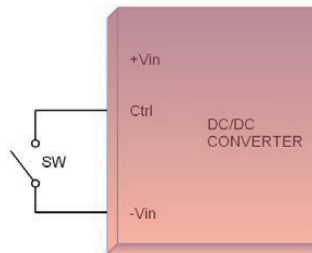

When PMF20W module is turned on at High-level logic

b. The negative logic structure turned on of the DC/DC module when the Ctrl pin is at low-level logic and turned off when at high-level logic.

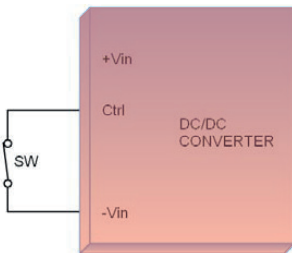

When PMF20W module is turned on at Low-level logic

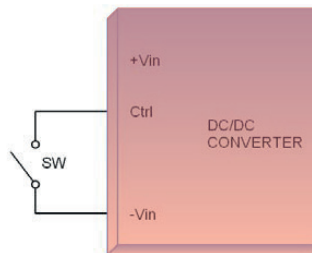

When PMF20W module is turned off at High-level logic

EMS Considerations

The PMF20 series can meet Fast Transient EN61000-4-4 and Surge EN61000-4-5 performance criteria A with external components connected to the input terminals of the module. Please see the following schematics as below.

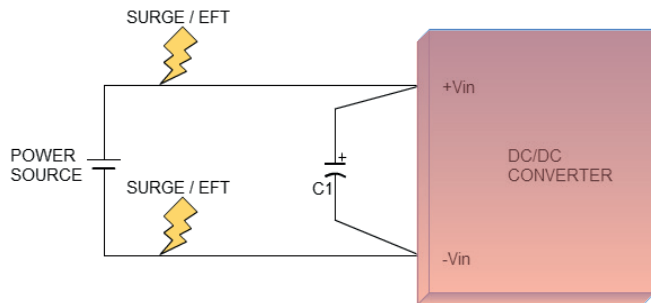

Surge/Fast Transient

PMF20-□□S□□W

Component	Value	Voltage	Reference
C1	220μF	100V	Nippon chemi-con KY-series

Mechanical Data

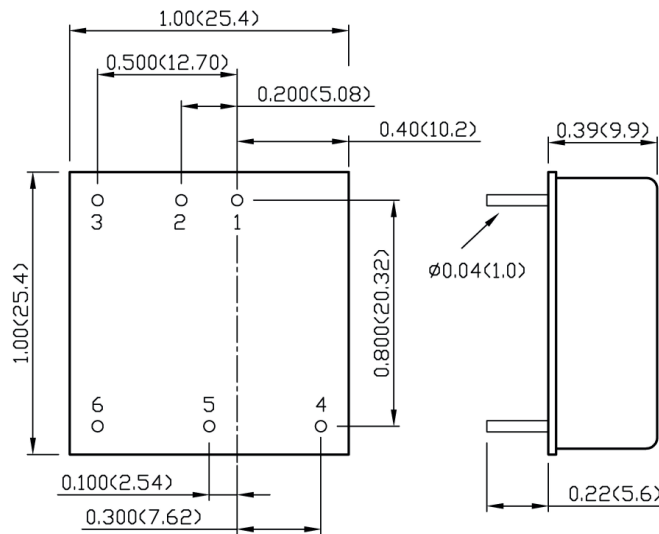

BOTTOM VIEW

- All dimensions in inch (mm)
- Tolerance: X.XX±0.02 (X.X±0.5)
X.XXX±0.01 (X.XX±0.25)
- Pin pitch tolerance ±0.01(0.25)
- Pin dimension tolerance ±0.004 (0.1)

Pin Connection

Pin	Define
1	+Vin
2	-Vin
3	Ctrl
4	+Vout
5	Trim
6	-Vout

Recommended Pad Layout

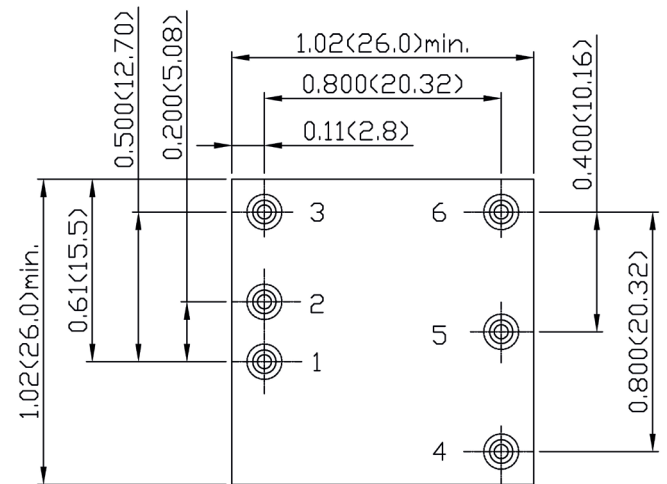

All dimensions in inch(mm)
 Pad size(lead free recommended)
 Through hole:ø0.051(ø1.30)
 Top view pad:ø0.064(ø1.63)
 Bottom view pad:ø0.102(ø2.60)

Soldering Considerations

Lead free wave solder profile

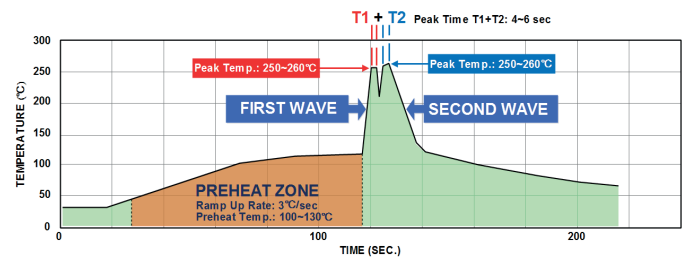

Reference Solder: Sn-Ag-Cu: Sn-Cu

Hand Welding (Reference):

Soldering iron: Power 150W

Welding Time: 3~6 sec

Temp: 410~430°C

Packing Information

Tube

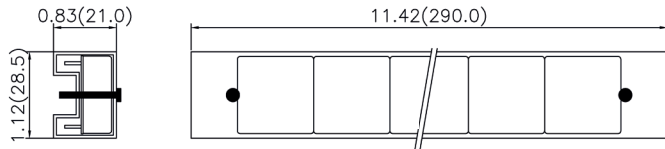

Tray

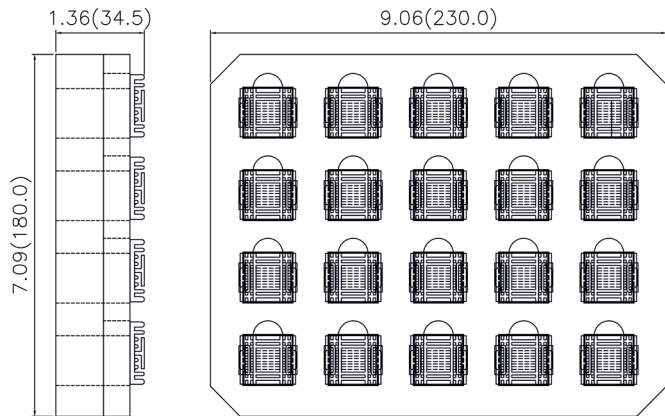

Model Type	Packing Material	Quantity
Without Heat-sink	Tube	10 PCS / Tube
With Heat-sink	Tray	20 PCS / Tray

Safety and Installation Instruction

Fusing Consideration

Caution: This power module is not internally fused. An input line fuse must always be used.

This encapsulated power module can be used in a wide variety of applications, ranging from simple stand-alone operation to an integrated part of sophisticated power architecture. To maximum flexibility, internal fusing is not included; however, to achieve maximum safety and system protection, always use an input line fuse. The input line fuse suggest as below:

Model	Fuse Rating	Fuse Type
PMF20-24D□□W	4	Slow-Blow
PMF20-48D□□W	2	Slow-Blow

Based on the information provided in this application note on Inrush energy and maximum DC input current at low Vin. If customer have another used condition and need more information, please contact Powerbox.

MTBF and Reliability

The MTBF of PMF20W DUAL-SERIES of DC/DC converters has been calculated using MIL-HDBK 217F NOTICE2 FULL LOAD, Operating Temperature at 25°C. The resulting figure for MTBF is 1.469x10⁶ hours.

The series modules can meet EN55022 A without external filter

Recommended external EMI filter for EN55022 Class B

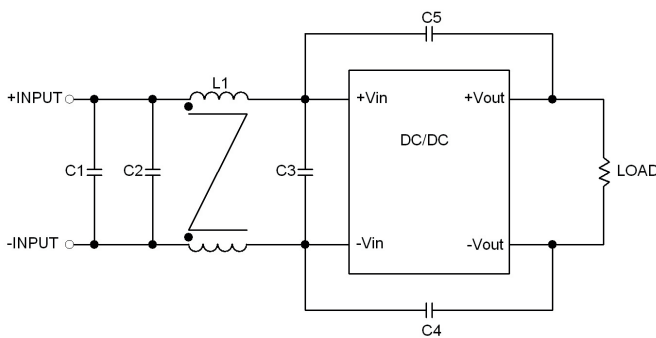

Single Output

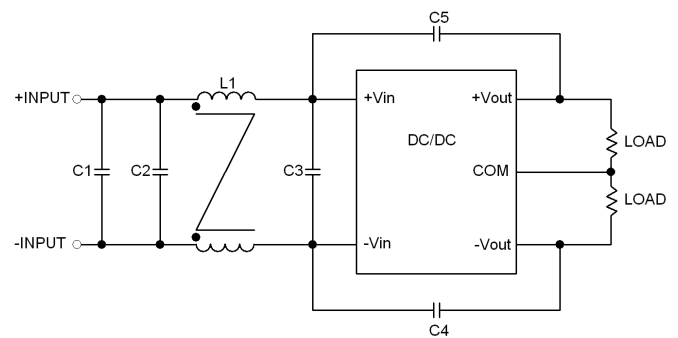

Dual Output

Model	C1	C2	C3	C4, C5	L1
PMF20-24□□□W	4.7μF/50V 1812 MLCC	N/A	N/A	470pF/2kV 1808 MLCC	325μH Common Choke PMT-050
PMF20-48□□□W	2.2μF/100V 1812 MLCC	2.2μF/100V 1812 MLCC	2.2μF/100V 1812 MLCC	1000pF/2kV 1808 MLCC	325μH Common Choke PMT-050