

# P R B X

## POWERBOX Industrial Line PFB400W Series 400W 4:1 Single Output DC/DC Converter

### Features

400W isolated output
Efficiency to 90%
Fixed switching frequency
Input under/over-voltage protection
Over temperature protection
Over voltage/current protection
Remote ON/OFF
Industry full-brick package
Fully isolated 1500VAC
Without tantalum capacitor inside

### Input

Voltage range	24V 9-36V 48V 18-75V
Under voltage lockout	24Vin power up: 8.5V. 24Vin power down: 7.5V 48Vin power up: 17V. 48Vin power down: 15V
Over voltage protection	24Vin turn off: 42V. 24V turn on: 40V 48Vin turn off: 83V. 48V turn on: 80V
Opto isolated remote ON/OFF	
Input filter	PI type.

### Output

Voltage accuracy	±1.5% max.
Transient response	<500u sec.
External trim adj. range	80-110%.
Load share accuracy <sup>5</sup>	±10% at 50% to 100% full load.
Auxiliary voltage/current	10±3VDC/20mA max.
Ripple and noise	5V 40mV rms max, 100mV pk-pk max
20MHz BW	12V 60mV rms max, 120mV pk-pk max 24V 100mV rms max, 240mV pk-pk max 28V 100mV rms max, 280mV pk-pk max 48V 120mV rms max, 480mV pk-pk max
Temperature coefficient	±0.03%/°C max.
Short circuit protection	Continuous.
Line regulation <sup>1</sup>	±0.2% max.
Load regulation <sup>2</sup>	±0.5% max.
Overvoltage protection	115-140%.
Current limit	110-150% nominal output.
Start up time	120ms typ.



### Environmental

Operating case temp.	-40°C to +100°C.
Storage temperature	-55°C to +110°C.
Thermal shutdown	Case temperature 110°C typ.
Humidity	95% RH max. Non-condensing.

### General

Efficiency	See table.
Isolation voltage	1500VDC min input/output, input/case, output/case.
Isolation resistance	10 <sup>7</sup> ohms, min.
Isolation capacitance	TBD typ.
Switching frequency	230KHz typ
MTBF	MIL-STD-217F, TBD hrs.
Dimensions	116.8 x 61.0 x 12.7 mm.
Case material	Aluminum baseplate with plastic case.
Weight	220 g.

### Standards

Safety standards	UL60950-1 approval.
------------------	---------------------

### Note:

1. Measured from high line to low line.
2. Measured from full load to zero load.
3. Output ripple and noise measured with 10uF tantalum and 1uF ceramic capacitor across output.
4. The output adjustment circuit and trim equations show as figure 1 and figure 2.
5. An external input capacitor 1000uF for 24Vin or 330uF for 48Vin models are recommended to reduce input ripple voltage.

**POWERBOX Industrial Line**  
**PFB400W Series**  
**400W 4:1 Single Output**  
**DC/DC Converter**

Model Number	Input Voltage	Output Voltage	Output Current		Input Current		Efficiency	Capacitive Load Max
			Min	Max	No Load	Full Load		
PFB400W-24S05	9-36VDC	5VDC	0mA	80 A	600mA	19.05A	87.5%	10000uF
PFB400W-24S12	9-36VDC	12VDC	0mA	33.3A	120mA	19.36A	86%	10000uF
PFB400W-24S24	9-36VDC	24VDC	0mA	16.7A	120mA	19.19A	87%	4700uF
PFB400W-24S28	9-36VDC	28VDC	0mA	14.3A	120mA	19.18A	87%	4700uF
PFB400W-24S48	9-36VDC	48VDC	0mA	8.3A	120mA	19.19A	86.5%	2200uF
PFB400W-48S05	18-75VDC	5VDC	0mA	80 A	300mA	9.36A	89%	10000uF
PFB400W-48S12	18-75VDC	12VDC	0mA	33.3A	60mA	9.41A	88.5%	10000uF
PFB400W-48S24	18-75VDC	24VDC	0mA	16.7A	60mA	9.28A	90%	4700uF
PFB400W-48S28	18-75VDC	28VDC	0mA	14.3A	60mA	9.27A	90%	4700uF
PFB400W-48S48	18-75VDC	48VDC	0mA	8.3A	60mA	9.27A	89.5%	2200uF

**Notes:**

- Nominal Input Voltage 24,48 VDC
- The output terminal of 12V,24V,28V&48Vout models required a minimum capacitor 330uF to maintain specified regulation.The output terminal of 05Vout models required a minimum capacitor 680uF to maintain specified regulation.

**Mechanical**

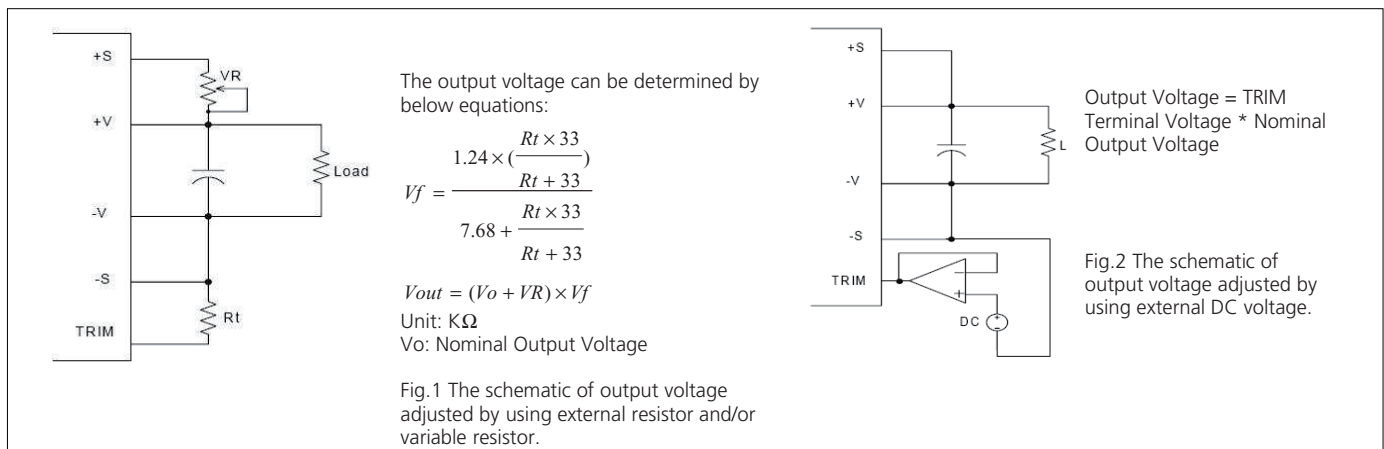
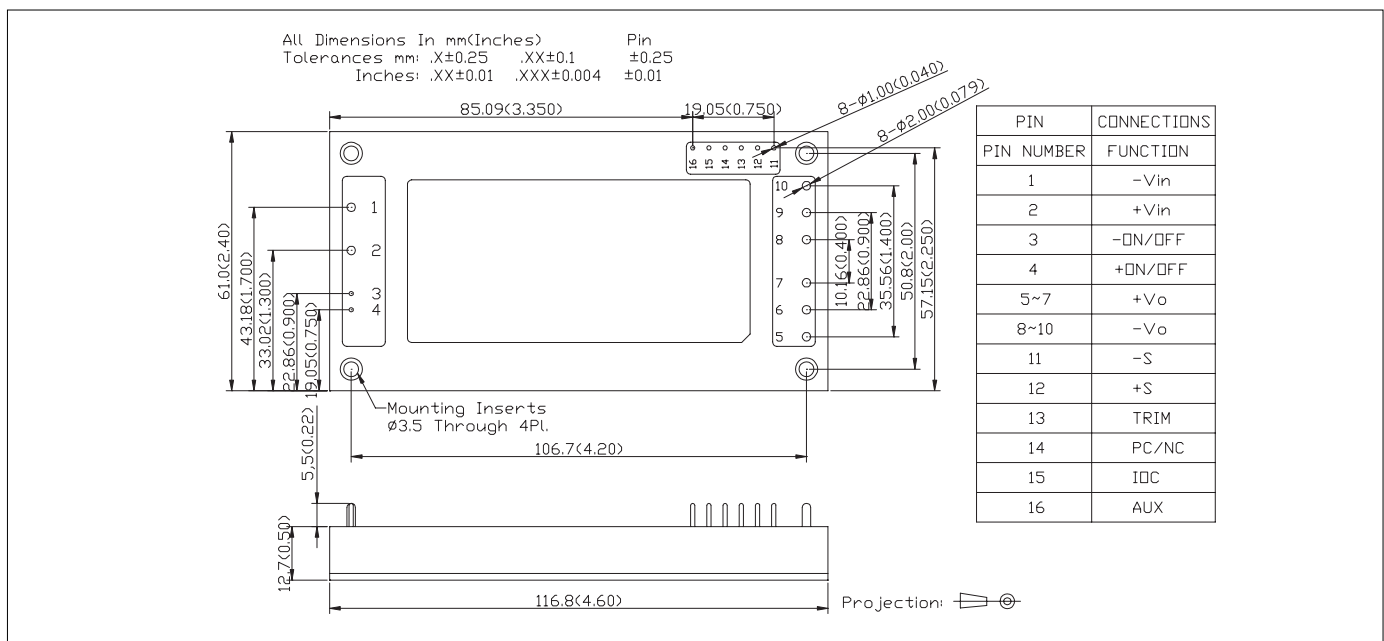

Specifications are subject to change without notice.