

POWERBOX

POWERBOX Industrial Line PED40W Series 40W 4:1 Single Output DC/DC Converter Manual

Table of Contents

Output specification	P2
Input specification	P3
General specification	P4
Environmental specifications	P4
EMC characteristic curves	P5
Test configurations	P35
EMC considerations	P36
Output voltage adjustment	P38
Input source impedance	P40
Output over current protection	P40
Thermal considerations	P40
Heat-sink considerations	P41
Remote on/off control	P41
Mechanical data	P42
Recommended pad layout	P42
Soldering considerations	P43
Packaging information	P43
Safety and installaion instruction	P43
MTBF and reliability	P43

Introduction

The PED40W series offer 40 watts of output power from a 2.00 x 1.00 x 0.40 inch package. PED40W series have 4:1 ultra wide input voltage of 9~36VDC, 18~75VDC and 43~160VDC. The PED40W have features 1600VDC of isolation, short circuit protection, over-current protection, over-voltage protection, over-temperature protection and six sided shielding.

DC/DC Converter Features

Single output up to 10A
Six-sided continuous shield
No minimum load required
High power density
High efficiency up to 92%
Small size 2.00x1.00x0.40 inch
Input to output isolation 1600VDC
4:1 ultra wide input voltage range
Fixed switching frequency
Input under-voltage protection
Output over-voltage protection
Over-current protection
Over-protection
Output short circuit protection
Remote on/off
Case grounding
Compliance to EN50155 and EN45545-2 railway standard

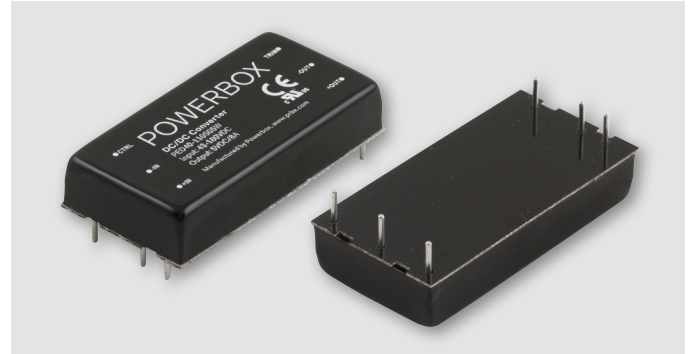

Output Specifications

Parameters	Model	Min	Typ	Max	Unit
Output voltage ($V_{in(nom)}$; full load; $T_a=25^\circ\text{C}$)	□□S3P3W	3.267	3.3	3.333	VDC
	□□S05W	4.95	5	5.05	VDC
	□□S12W	11.88	12	12.12	VDC
	□□S15W	14.85	15	15.15	VDC
	□□S24W	23.76	24	24.24	VDC
Voltage adjustability	□□S15W	-10		+20	% of V_{out}
	□□S24W	-10		+20	% of V_{out}
	Others	-10		+10	% of V_{out}
<i>Output regulation</i>					
Line ($V_{in(min)}$ to $V_{in(max)}$; full load)	All	-0.2		+0.2	%
Load (0% to 100% of full load)	All	-0.5		+0.5	%
Output ripple and noise Peak to peak (5Hz to 20MHz bandwidth) (Measured with 0.1 μF /50V MLCC)	□□S3P3W		75	100	mVp-p
	□□S05W		75	100	mVp-p
	□□S12W		100	150	mVp-p
	□□S15W		100	150	mVp-p
	□□S24W		150	200	mVp-p
Temperature coefficient	All	-0.02		+0.02	%/ $^\circ\text{C}$
Output voltage overshoot ($V_{in(min)}$ to $V_{in(max)}$ full load; $T_a=25^\circ\text{C}$)	All		0	3	% of V_{out}
<i>Dynamic load response ($V_{in(nom)}$; $T_a=25^\circ\text{C}$)</i>					
Load step change from 75% to 100% or 100 to 75% of full load					
Peak deviation	All		200		mV
Setting time ($V_o < 10\%$ peak deviation)	All		250		μs
Output current	□□S3P3W	0		10000	mA
	□□S05W	0		8000	mA
	□□S12W	0		3333	mA
	□□S15W	0		2666	mA
	□□S24W	0		1666	mA
Output capacitance load	□□S3P3W			26600	μF
	□□S05W			20000	μF
	□□S12W			3900	μF
	□□S15W			2600	μF
	□□S24W			1300	μF
Output over voltage protection (zener diode clamp)	□□S3P3W		3.9		VDC
	□□S05W		6.2		VDC
	□□S12W		15		VDC
	□□S15W		20		VDC
	□□S24W		31		VDC
Output over current protection (% of I_{out} rated; hiccup mode)	All		150		% of FL
Output short circuit protection	All	Hiccup, automatic recovery			

POWERBOX Industrial Line
 PED40W Series
 40W 4:1 Single Output
 DC/DC Converter
 Manual

Input Specifications

Parameters	Model	Min	Typ	Max	Unit
<i>Operating input voltage</i>					
Continuous	24S□□W	9	24	36	VDC
	48S□□W	18	48	75	VDC
	110S□□W	43	110	160	VDC
Transient (100ms,max)	24S□□W			50	VDC
	48S□□W			100	VDC
	110S□□W			185	VDC
Input standby current (Vin(nom); No Load)	24S3P3W		15		mA
	24S05W		15		mA
	24S12W		15		mA
	24S15W		15		mA
	24S24W		15		mA
	48S3P3W		10		mA
	48S05W		10		mA
	48S12W		10		mA
	48S15W		10		mA
	48S24W		10		mA
	110S3P3W		6		mA
	110S05W		6		mA
	110S12W		6		mA
110S15W		6		mA	
110S24W		6		mA	
Under voltage lockout turn-on threshold	24S□□W			9	VDC
	48S□□W			18	VDC
	110S□□W			43	VDC
Under voltage lockout turn-off threshold	24S□□W		8		VDC
	48S□□W		16		VDC
	110S□□W		40		VDC
Input reflected ripple current (5 to 20MHz, 12μH source impedance)	All		20		mA _{p-p}
Start up time (Vin(nom) and constant resistive load)					
Power up	All		60		ms
Remote on/off	All		60		ms
<i>Remote ON/OFF control (The Ctrl pin voltage is referenced to negative input)</i>					
Positive logic (standard)					
Device code without suffix					
On/Off pin high voltage (Remote ON)	All	3.0		12	VDC
On/Off pin low voltage (Remote OFF)	All	0		1.2	VDC
Negative logic (option)					
Device code with suffix "N"					
On/Off pin low voltage (Remote ON)	All	0		1.2	VDC
On/Off pin high voltage (Remote OFF)	All	3.0		12	VDC
Remote off state input current			3		mA
Input current of remote control pin		-0.5		0.5	mA

General Specifications

Parameters	Model	Min	Typ	Max	Unit
Efficiency (Vin(nom); full load; Ta=25°C)	24S3P3W		90		%
	24S05W		91		%
	24S12W		91		%
	24S15W		91		%
	24S24W		91		%
	48S3P3W		90		%
	48S05W		91		%
	48S12W		92		%
	48S15W		92		%
	48S24W		91		%
	110S3P3W		88		%
	110S05W		89		%
	110S12W		90.5		%
	110S15W		90		%
110S24W		90		%	
Isolation voltage (1 minute) Input to output	110V(nom)	3000			VDC
	Input to chassis, output to chassis	110V(nom)	1600		VDC
Isolation voltage (1 minute) Input to output	Others	1600			VDC
	Input to chassis, output to chassis	Others	1600		VDC
Isolation resistance (500VDC)	All	1			GΩ
Isolation capacitance	All			1500	pF
Switching frequency	All	225	250	275	kHz
Weight	All		32.0		g
MTBF MIL-HDBK-217F	All		9.073 x 10 ⁵		hours
Dimensions	All	2.00 x 1.00 x 0.40			Inch
	All	50.8 x 25.4 x 10.2			mm
Case material	All	Copper			
Base material	All	FR4 PCB			
Potting material	All	Silicone (UL94 V-0)			

Environmental Specifications

Parameters	Model	Min	Typ	Max	Unit
Operating case temperature	All	-40		105	°C
Storage temperature	All	-55		125	°C
Over temperature protection	All		115		°C
<i>Thermal impedance (20LFM)</i>					
Without heat-sink	All		10.8		°C/W
With heat-sink	All		10.3		°C/W
Relative humidity	All	5		95	% RH
Thermal shock/Vibration	All	EN61373, MIL-STD-810F			

EMC Characteristics

Parameters	Standard	Condition		Level
EMI	EN55011			Class A
	EN55022			Perf. Criteria A
ESD	EN61000-4-2	Air	±8kV	
		Contact	±6kV	
Radiated Immunity	EN61000-4-3		20V/m	Perf. Criteria A
Fast Transient	EN61000-4-4		±2kV	Perf. Criteria A
Surge	EN61000-4-5		±2kV	Perf. Criteria A
Conducted Immunity	EN61000-4-6		10V r.m.s	Perf. Criteria A
Power Frequency Magnetic Field	EN61000-4-8	100A/m continuous;		Perf. Criteria A
		1000A/m 1 second		

POWERBOX Industrial Line
 PED40W Series
 40W 4:1 Single Output
 DC/DC Converter
 Manual

All test conditions are at 25°C. The figures are identical for PED40-24S3P3W

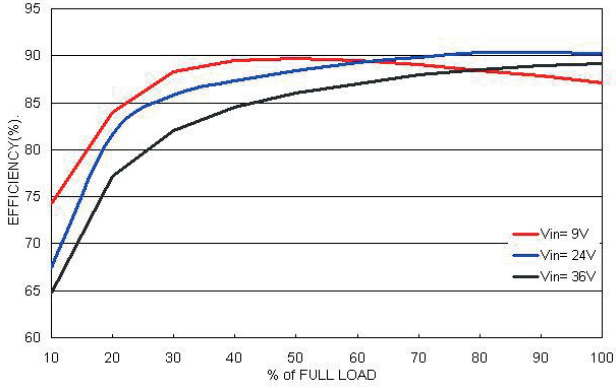

Efficiency versus Output Current
 $V_{in}=V_{in(nom)}$

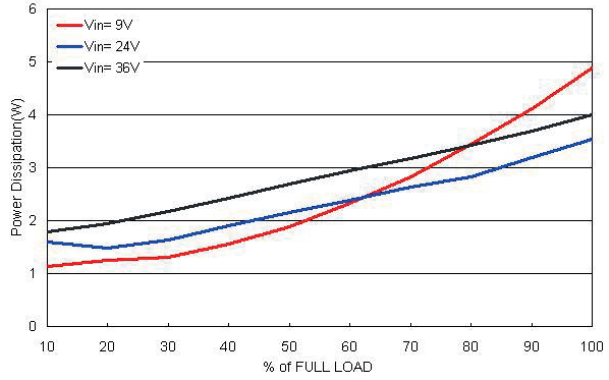

Power dissipation versus Output Current
 $V_{in}=V_{in(nom)}$

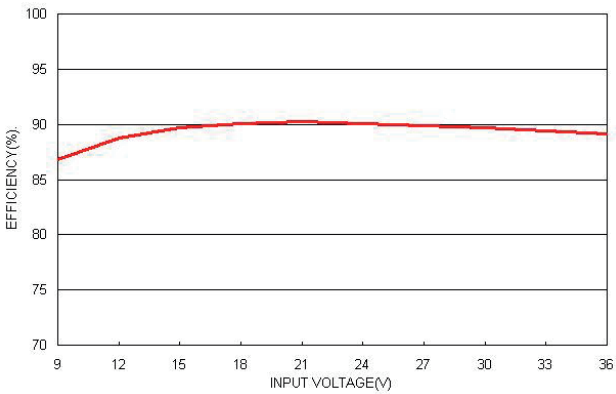

Efficiency versus Input Voltage
 Full Load

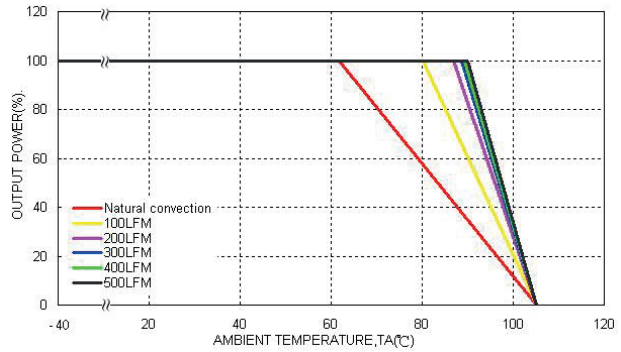

Derating Output Current versus Ambient Temperature and Airflow
 $V_{in}=V_{in(nom)}$

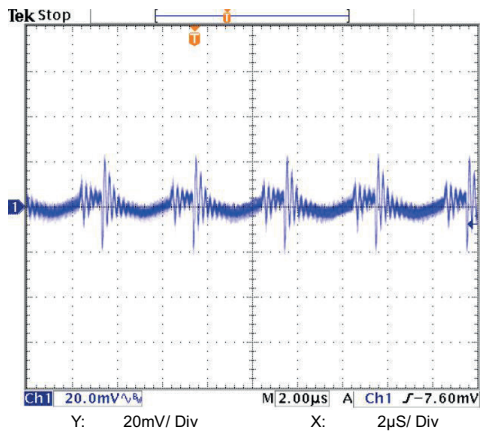

Typical Output Ripple and Noise.
 $V_{in}=V_{in(nom)}$; Full Load

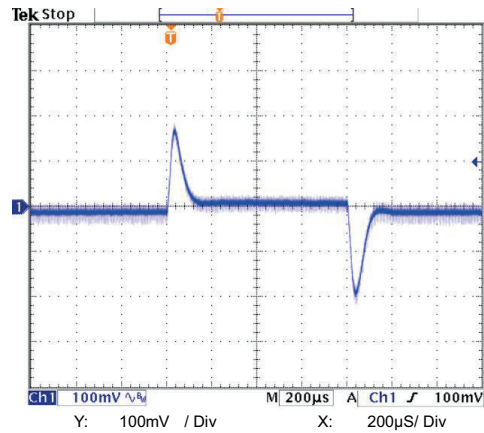

Transient Response to Dynamic Load Change from
 100% to 75% to 100% of Full Load; $V_{in}=V_{in(nom)}$

All test conditions are at 25°C. The figures are identical for PED40-24S3P3W

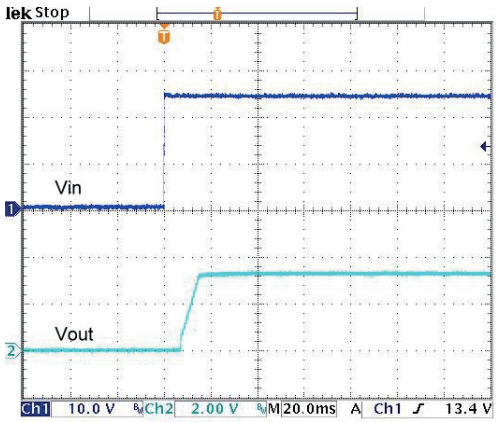

Typical Input Start-Up and Output Rise Characteristic
 $V_{in}=V_{in}(nom)$; Full Load

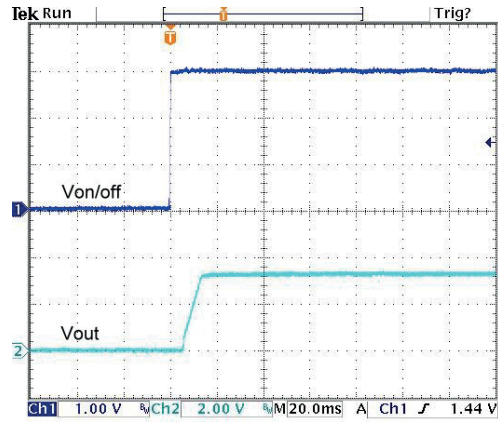

Using ON/OFF Voltage Start-Up and Output Rise Characteristic
 $V_{in}=V_{in}(nom)$; Full Load

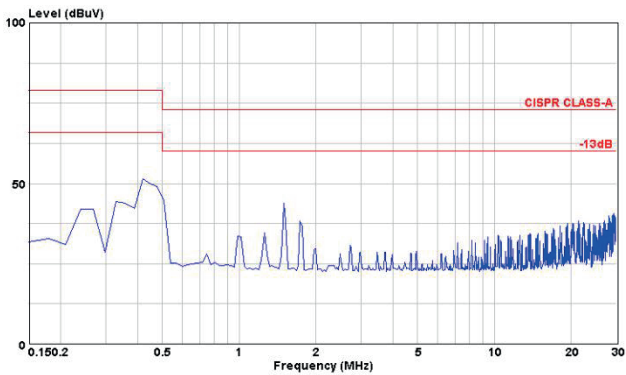

Conduction Emission of EN55022 Class A
 $V_{in}=V_{in}(nom)$; Full Load

POWERBOX Industrial Line
 PED40W Series
 40W 4:1 Single Output
 DC/DC Converter
 Manual

All test conditions are at 25°C. The figures are identical for PED40-24S05W

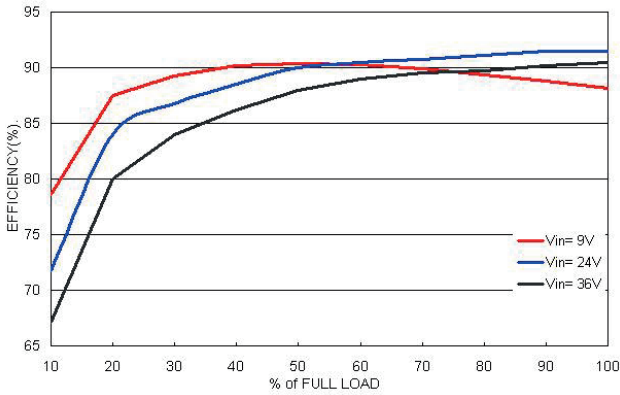

Efficiency versus Output Current
 Vin=Vin(nom)

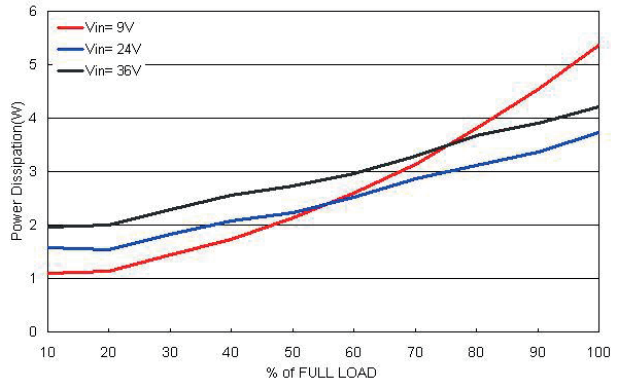

Power dissipation versus Output Current
 Vin=Vin(nom)

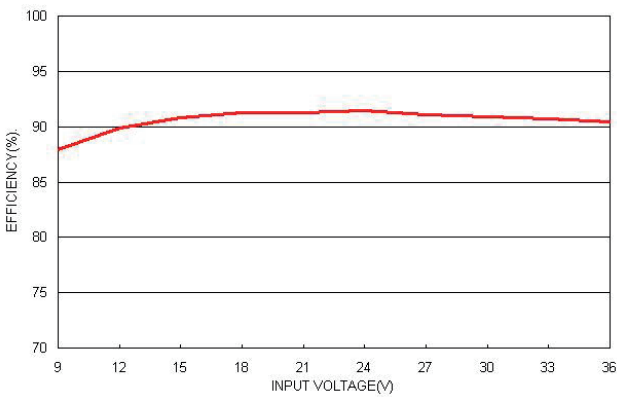

Efficiency versus Input Voltage
 Full Load

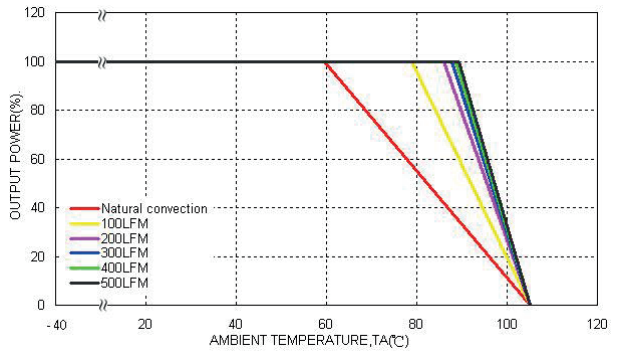

Derating Output Current versus Ambient Temperature and Airflow
 Vin=Vin(nom)

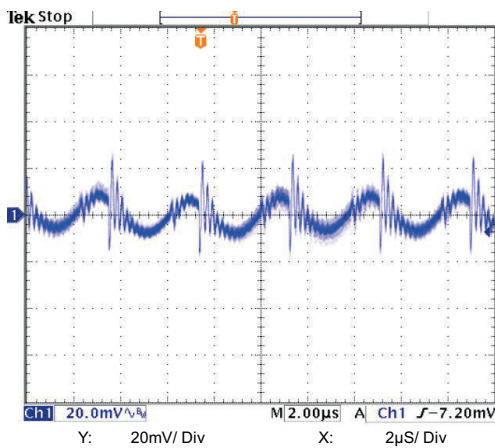

Typical Output Ripple and Noise.
 Vin=Vin(nom); Full Load

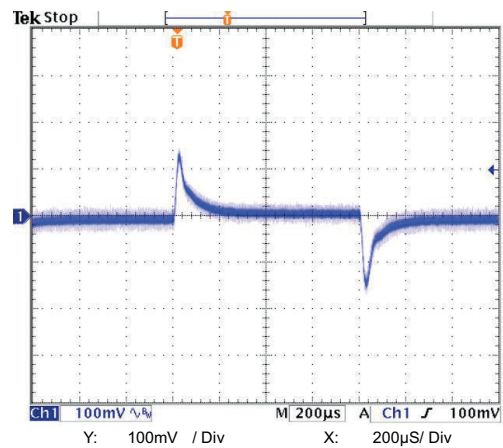

Transient Response to Dynamic Load Change from
 100% to 75% to 100% of Full Load; Vin=Vin(nom)

All test conditions are at 25°C. The figures are identical for PED40-24S05W

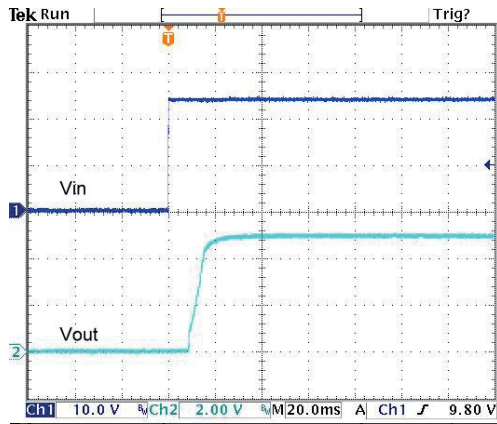

Typical Input Start-Up and Output Rise Characteristic
 $V_{in}=V_{in(nom)}$; Full Load

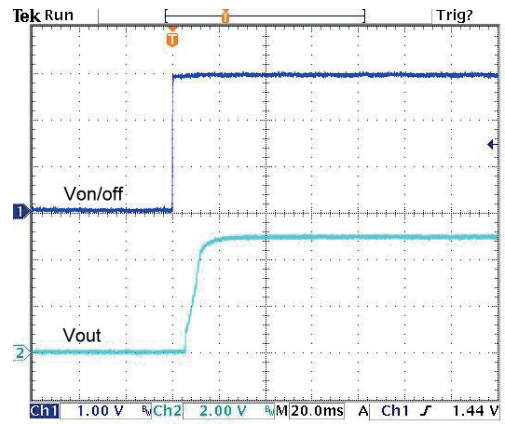

Using ON/OFF Voltage Start-Up and Output Rise Characteristic
 $V_{in}=V_{in(nom)}$; Full Load

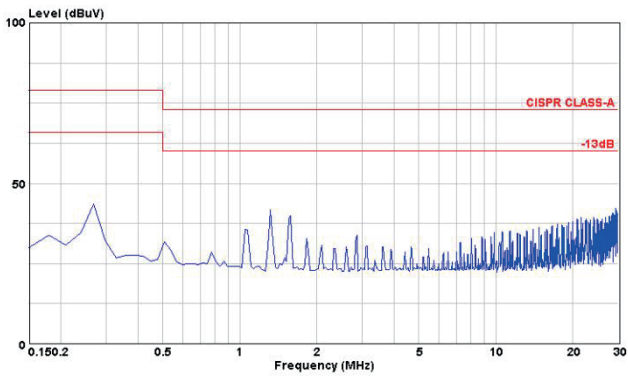

Conduction Emission of EN55022 Class A
 $V_{in}=V_{in(nom)}$; Full Load

POWERBOX Industrial Line
 PED40W Series
 40W 4:1 Single Output
 DC/DC Converter
 Manual

All test conditions are at 25°C. The figures are identical for PED40-24S12W

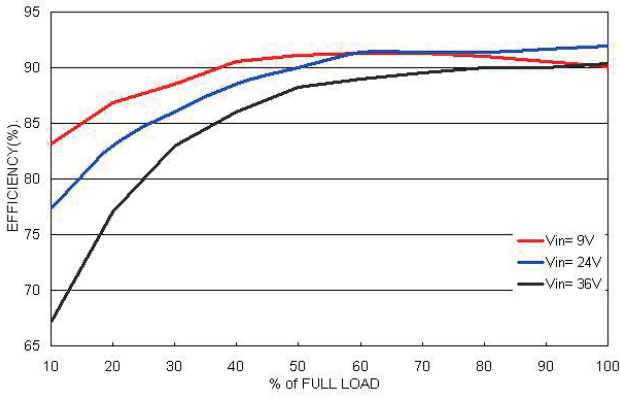

Efficiency versus Output Current
 Vin=Vin(nom)

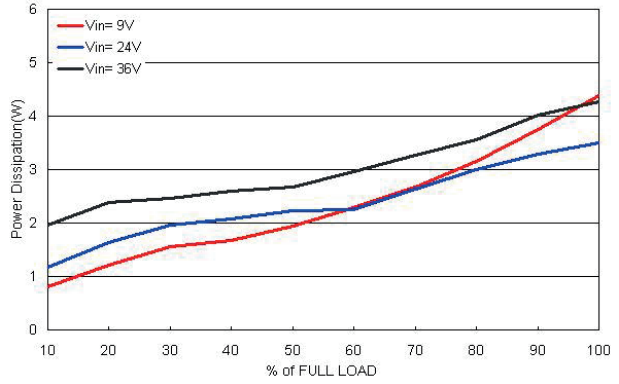

Power dissipation versus Output Current
 Vin=Vin(nom)

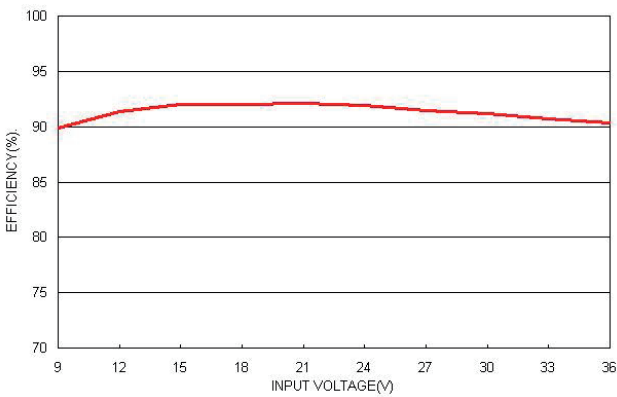

Efficiency versus Input Voltage
 Full Load

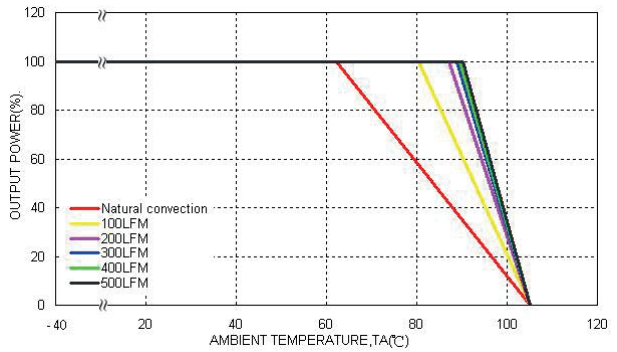

Derating Output Current versus Ambient Temperature and Airflow
 Vin=Vin(nom)

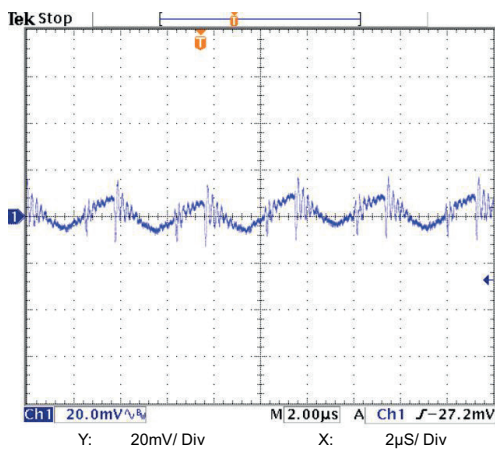

Typical Output Ripple and Noise.
 Vin=Vin(nom); Full Load

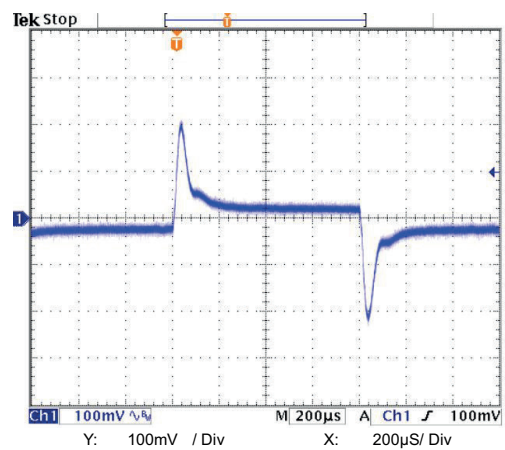

Transient Response to Dynamic Load Change from
 100% to 75% to 100% of Full Load; Vin=Vin(nom)

All test conditions are at 25°C. The figures are identical for PED40-24S12W

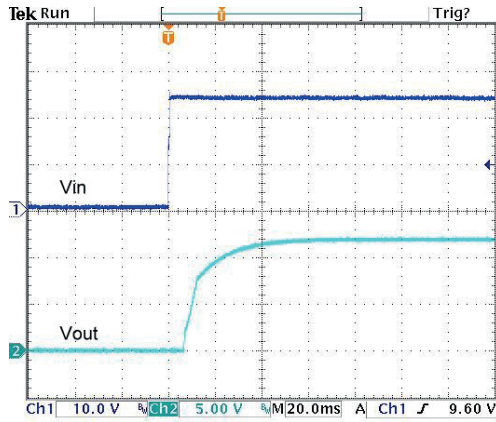

Typical Input Start-Up and Output Rise Characteristic
 $V_{in}=V_{in}(nom)$; Full Load

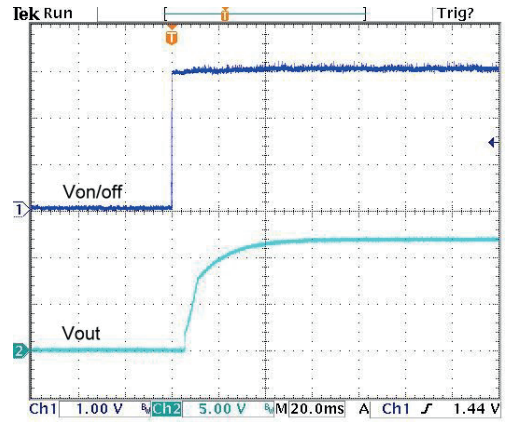

Using ON/OFF Voltage Start-Up and Output Rise Characteristic
 $V_{in}=V_{in}(nom)$; Full Load

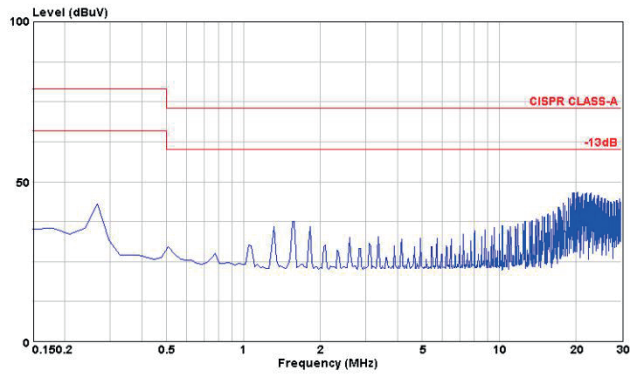

Conduction Emission of EN55022 Class A
 $V_{in}=V_{in}(nom)$; Full Load

POWERBOX Industrial Line
 PED40W Series
 40W 4:1 Single Output
 DC/DC Converter
 Manual

All test conditions are at 25°C. The figures are identical for PED40-24S15W

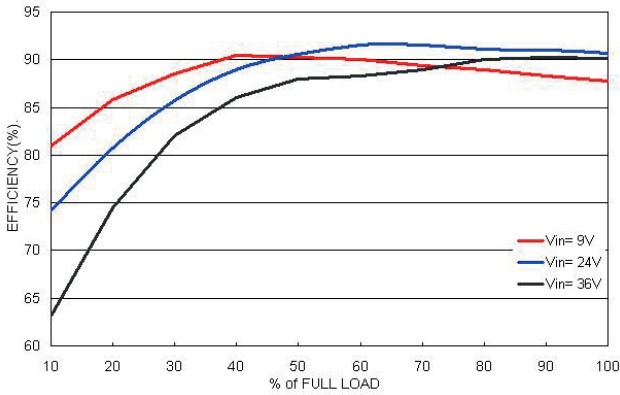

Efficiency versus Output Current
 Vin=Vin(nom)

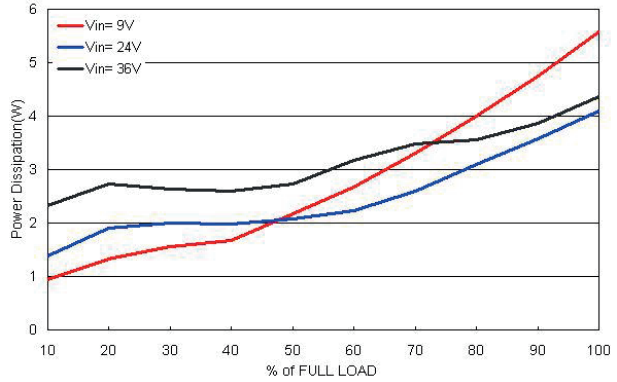

Power dissipation versus Output Current
 Vin=Vin(nom)

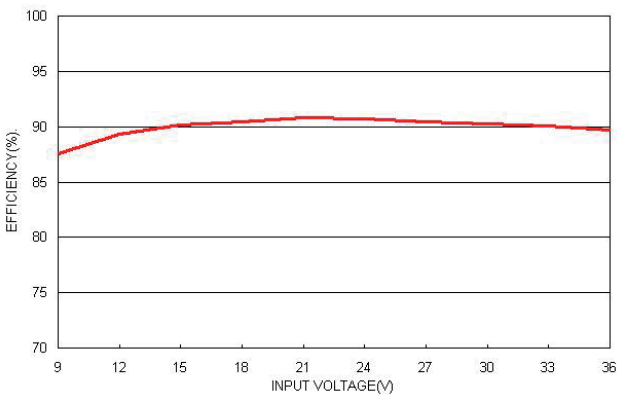

Efficiency versus Input Voltage
 Full Load

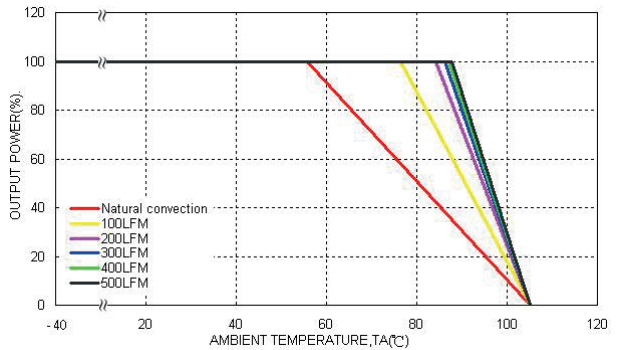

Derating Output Current versus Ambient Temperature and Airflow
 Vin=Vin(nom)

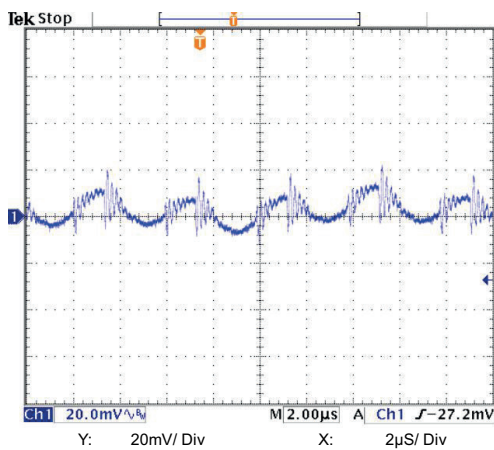

Typical Output Ripple and Noise.
 Vin=Vin(nom); Full Load

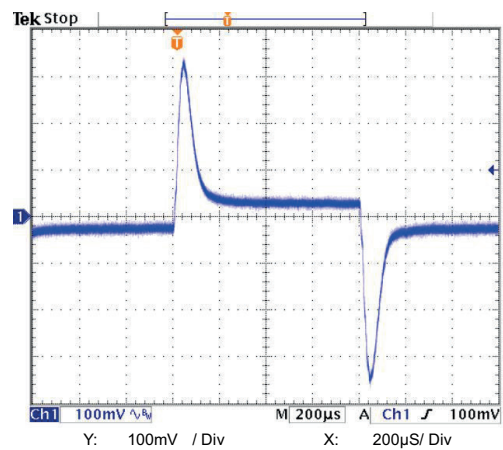

Transient Response to Dynamic Load Change from
 100% to 75% to 100% of Full Load; Vin=Vin(nom)

All test conditions are at 25°C. The figures are identical for PED40-24S15W

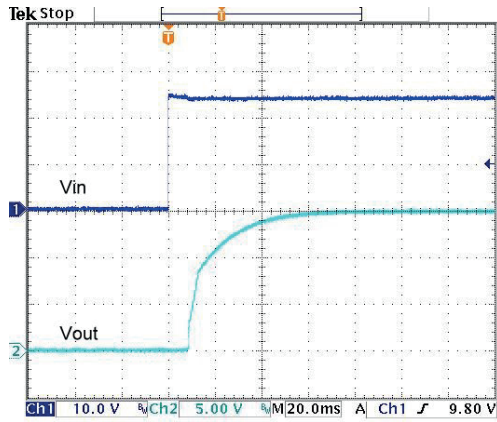

Typical Input Start-Up and Output Rise Characteristic
 $V_{in}=V_{in}(nom)$; Full Load

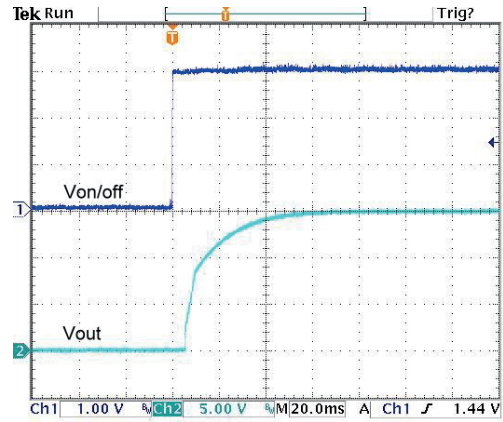

Using ON/OFF Voltage Start-Up and Output Rise Characteristic
 $V_{in}=V_{in}(nom)$; Full Load

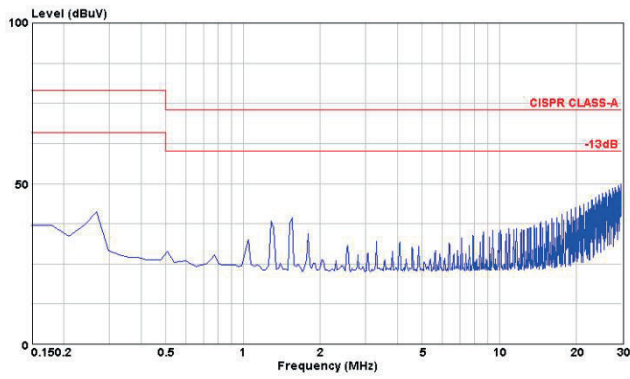

Conduction Emission of EN55022 Class A
 $V_{in}=V_{in}(nom)$; Full Load

POWERBOX Industrial Line
 PED40W Series
 40W 4:1 Single Output
 DC/DC Converter
 Manual

All test conditions are at 25°C. The figures are identical for PED40-24S24W

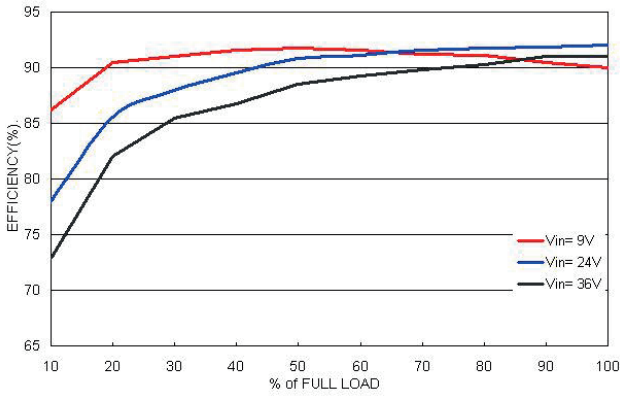

Efficiency versus Output Current
 Vin=Vin(nom)

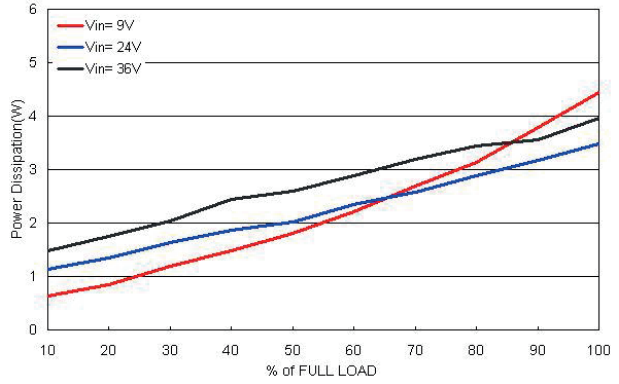

Power dissipation versus Output Current
 Vin=Vin(nom)

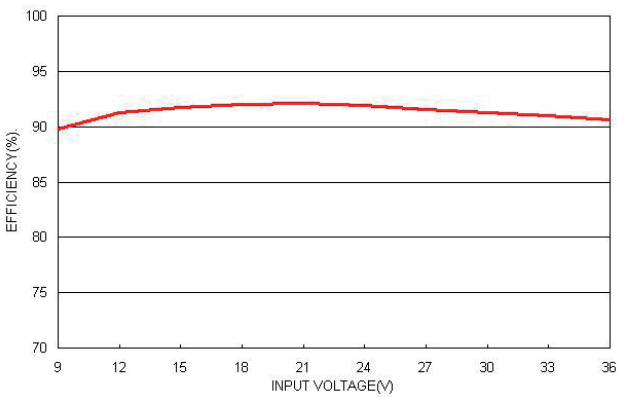

Efficiency versus Input Voltage
 Full Load

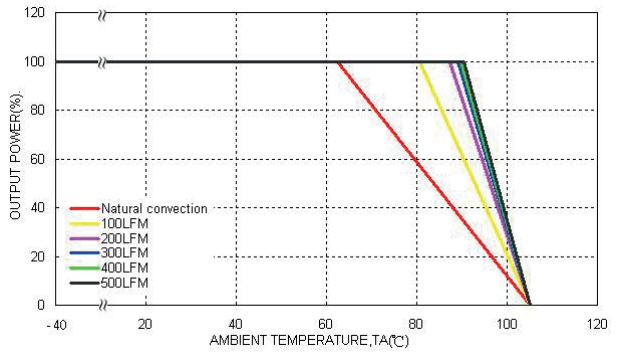

Derating Output Current versus Ambient Temperature and Airflow
 Vin=Vin(nom)

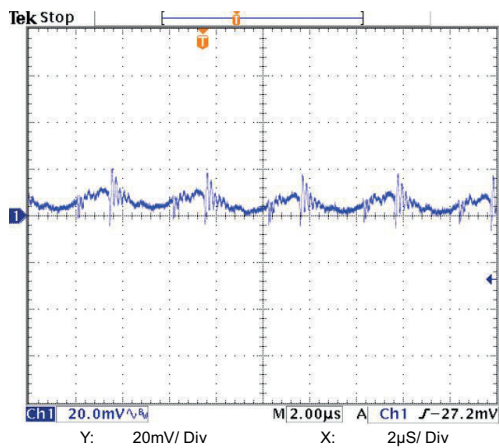

Typical Output Ripple and Noise.
 Vin=Vin(nom); Full Load

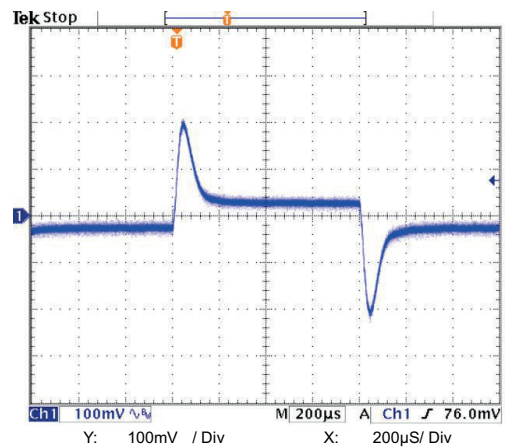

Transient Response to Dynamic Load Change from
 100% to 75% to 100% of Full Load; Vin=Vin(nom)

All test conditions are at 25°C. The figures are identical for PED40-24S24W

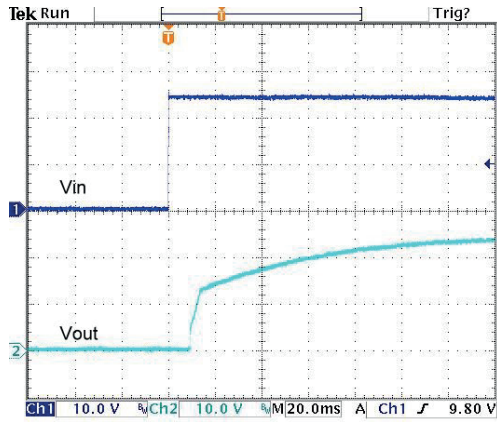

Typical Input Start-Up and Output Rise Characteristic
 $V_{in}=V_{in(nom)}$; Full Load

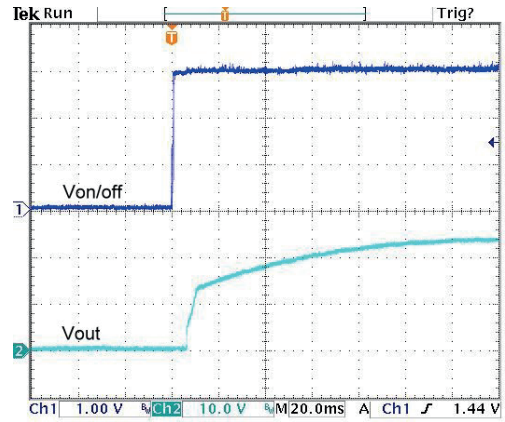

Using ON/OFF Voltage Start-Up and Output Rise Characteristic
 $V_{in}=V_{in(nom)}$; Full Load

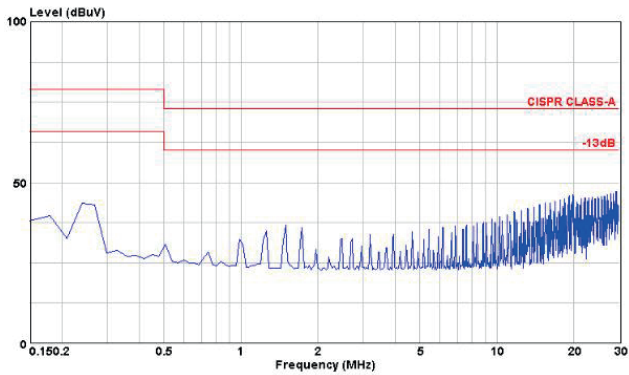

Conduction Emission of EN5522 Class A
 $V_{in}=V_{in(nom)}$; Full Load

POWERBOX Industrial Line
 PED40W Series
 40W 4:1 Single Output
 DC/DC Converter
 Manual

All test conditions are at 25°C. The figures are identical for PED40-48S3P3W

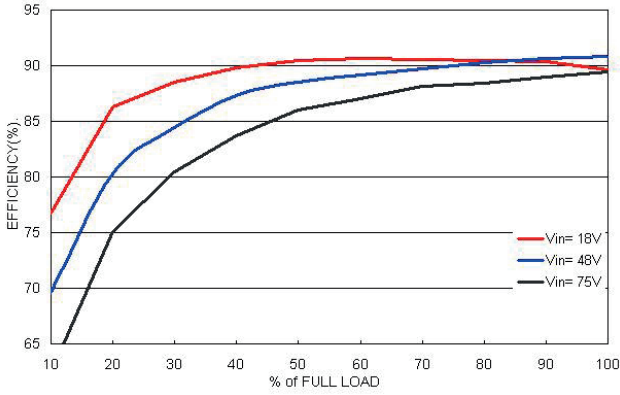

Efficiency versus Output Current
 Vin=Vin(nom)

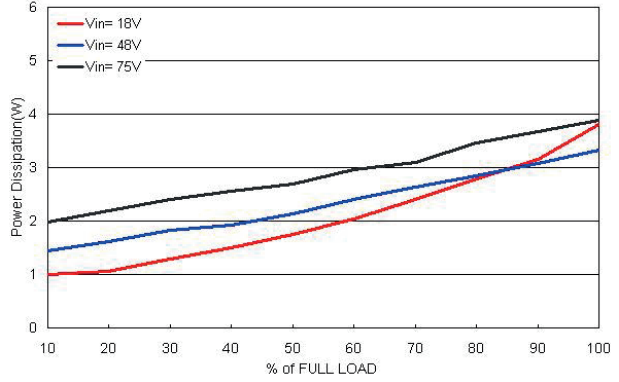

Power dissipation versus Output Current
 Vin=Vin(nom)

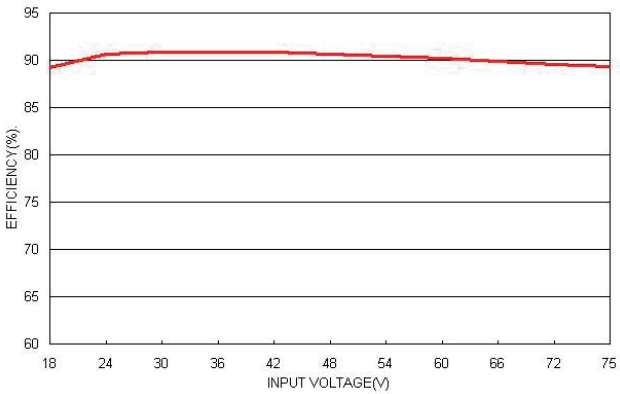

Efficiency versus Input Voltage
 Full Load

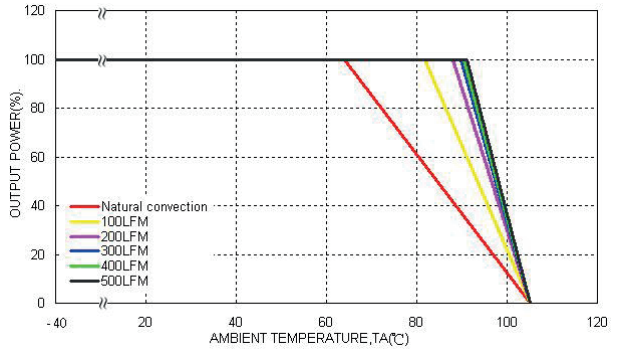

Derating Output Current versus Ambient Temperature and Airflow
 Vin=Vin(nom)

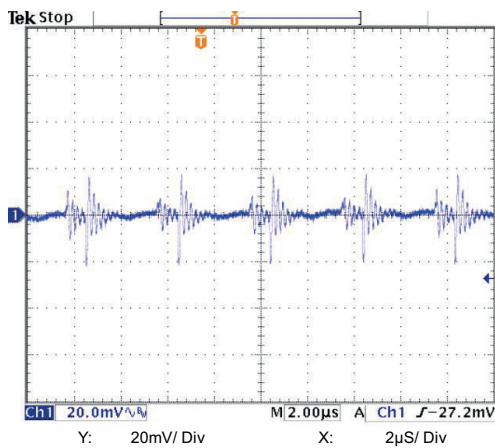

Typical Output Ripple and Noise.
 Vin=Vin(nom); Full Load

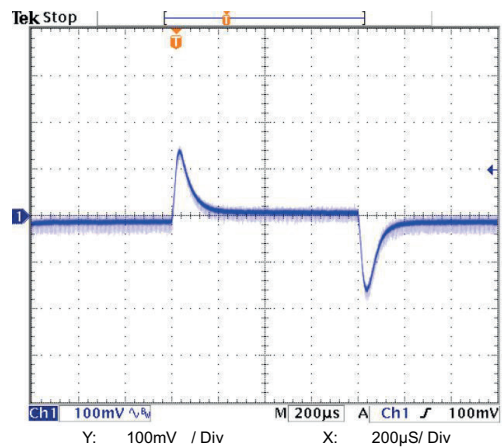

Transient Response to Dynamic Load Change from
 100% to 75% to 100% of Full Load; Vin=Vin(nom)

All test conditions are at 25°C. The figures are identical for PED40-48S3P3W

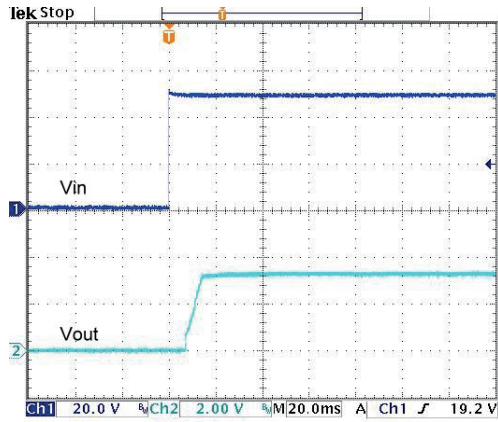

Typical Input Start-Up and Output Rise Characteristic
 $V_{in}=V_{in}(nom)$; Full Load

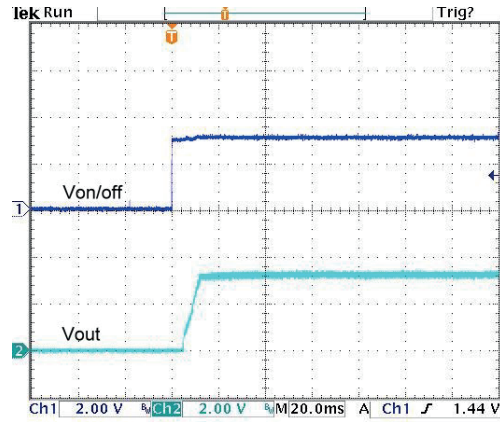

Using ON/OFF Voltage Start-Up and Output Rise Characteristic
 $V_{in}=V_{in}(nom)$; Full Load

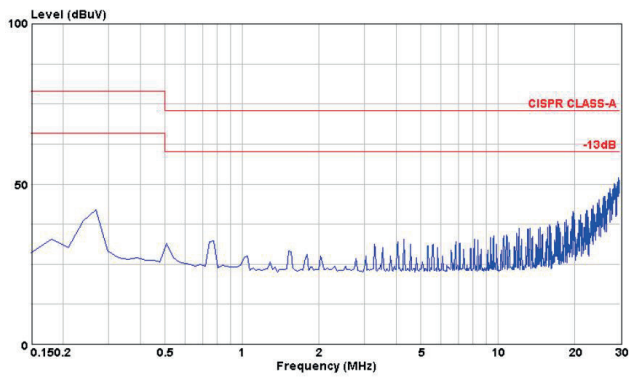

Conduction Emission of EN55022 Class A
 $V_{in}=V_{in}(nom)$; Full Load

POWERBOX Industrial Line
 PED40W Series
 40W 4:1 Single Output
 DC/DC Converter
 Manual

All test conditions are at 25°C. The figures are identical for PED40-48S05W

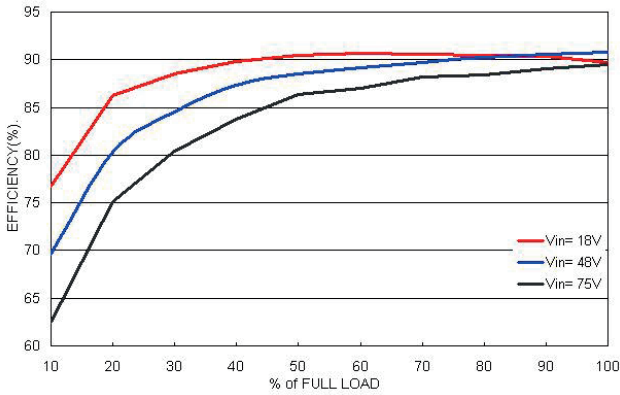

Efficiency versus Output Current
 $V_{in}=V_{in(nom)}$

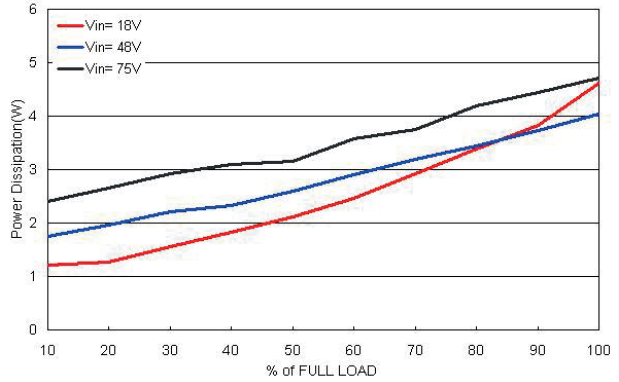

Power dissipation versus Output Current
 $V_{in}=V_{in(nom)}$

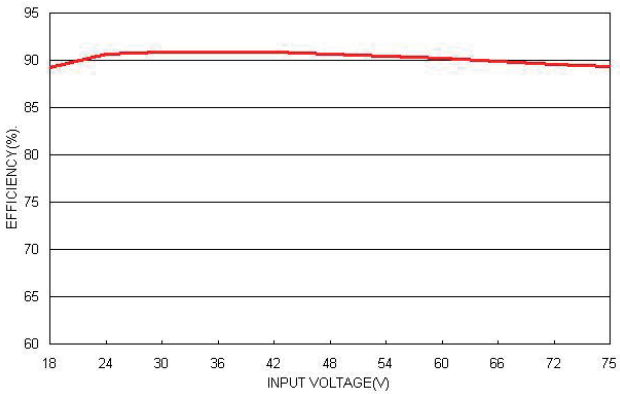

Efficiency versus Input Voltage
 Full Load

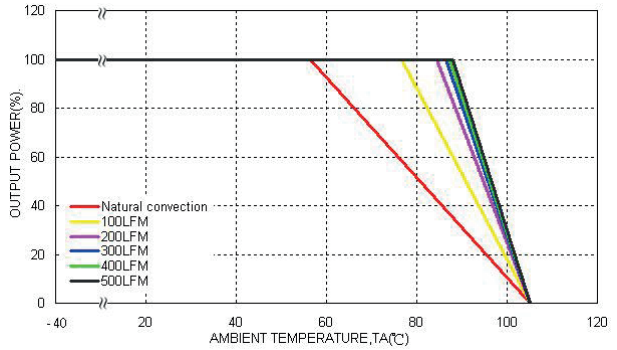

Derating Output Current versus Ambient Temperature and Airflow
 $V_{in}=V_{in(nom)}$

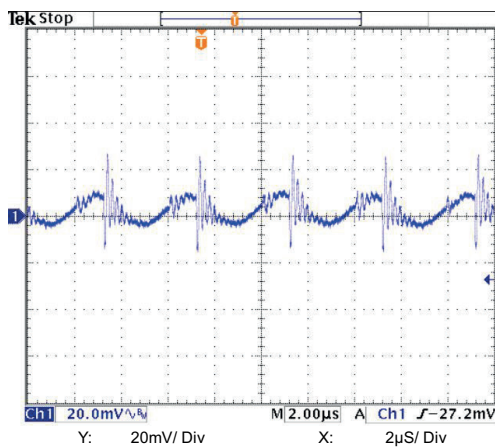

Typical Output Ripple and Noise.
 $V_{in}=V_{in(nom)}$; Full Load

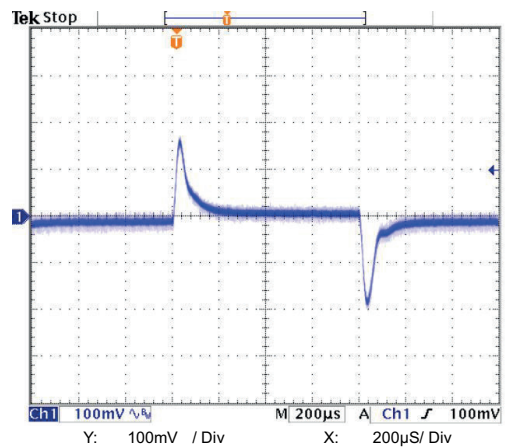

Transient Response to Dynamic Load Change from
 100% to 75% to 100% of Full Load; $V_{in}=V_{in(nom)}$

All test conditions are at 25°C. The figures are identical for PED40-48S05W

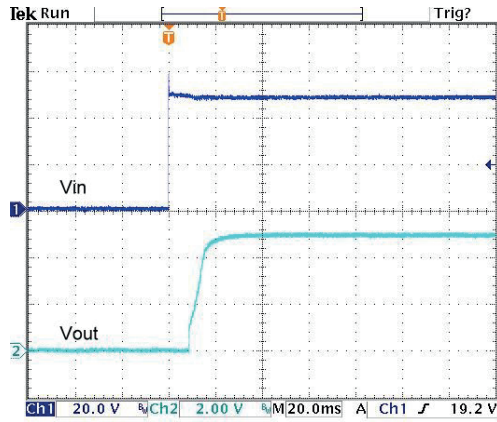

Typical Input Start-Up and Output Rise Characteristic
 $V_{in}=V_{in}(nom)$; Full Load

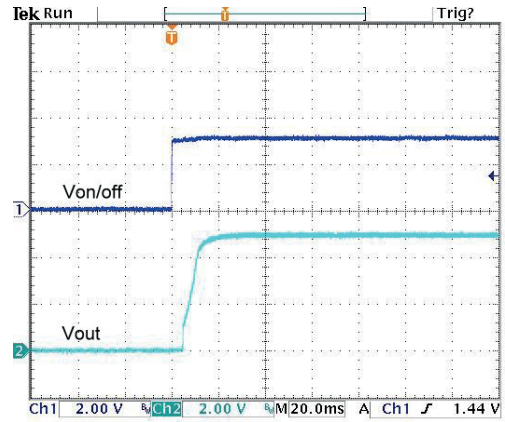

Using ON/OFF Voltage Start-Up and Output Rise Characteristic
 $V_{in}=V_{in}(nom)$; Full Load

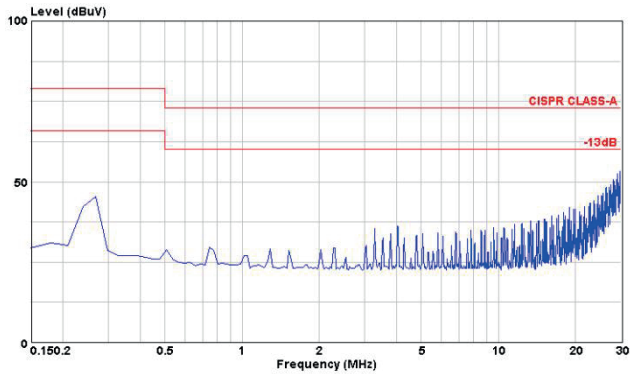

Conduction Emission of EN55022 Class A
 $V_{in}=V_{in}(nom)$; Full Load

POWERBOX Industrial Line
 PED40W Series
 40W 4:1 Single Output
 DC/DC Converter
 Manual

All test conditions are at 25°C. The figures are identical for PED40-48S12W

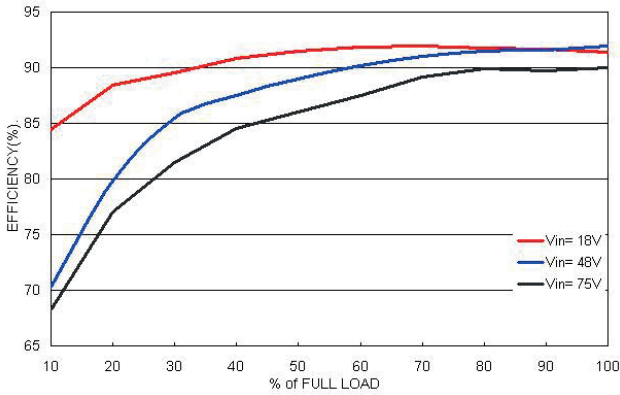

Efficiency versus Output Current
 Vin=Vin(nom)

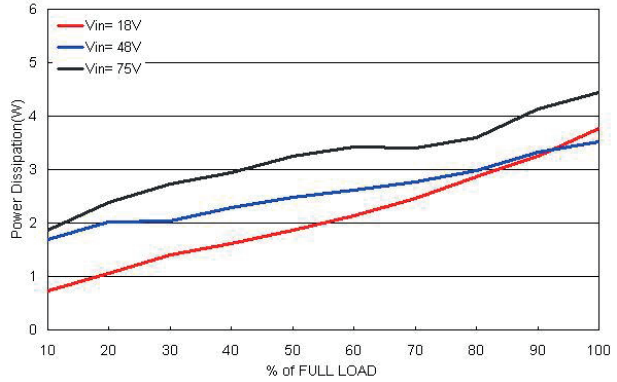

Power dissipation versus Output Current
 Vin=Vin(nom)

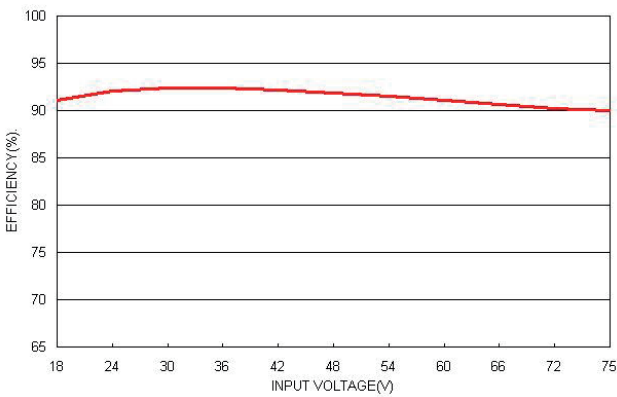

Efficiency versus Input Voltage
 Full Load

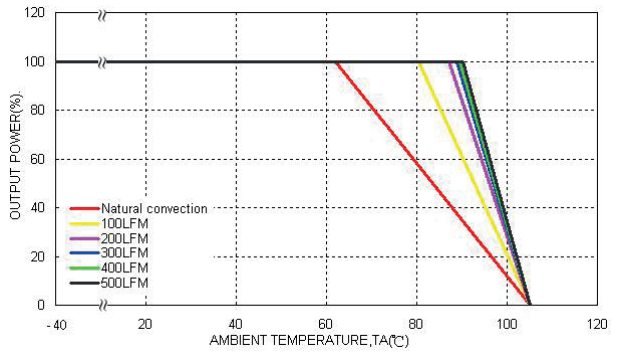

Derating Output Current versus Ambient Temperature and Airflow
 Vin=Vin(nom)

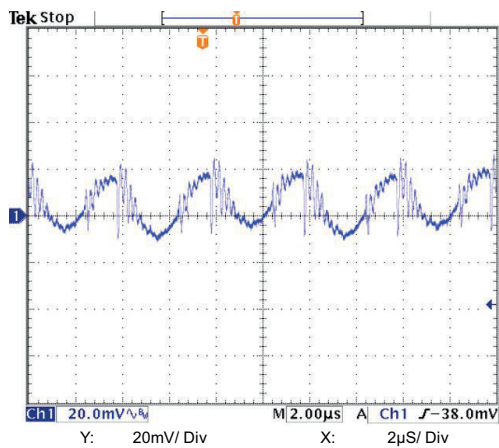

Typical Output Ripple and Noise.
 Vin=Vin(nom); Full Load

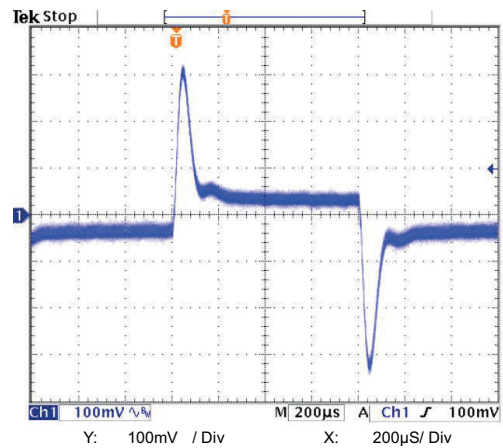

Transient Response to Dynamic Load Change from
 100% to 75% to 100% of Full Load; Vin=Vin(nom)

All test conditions are at 25°C. The figures are identical for PED40-48S12W

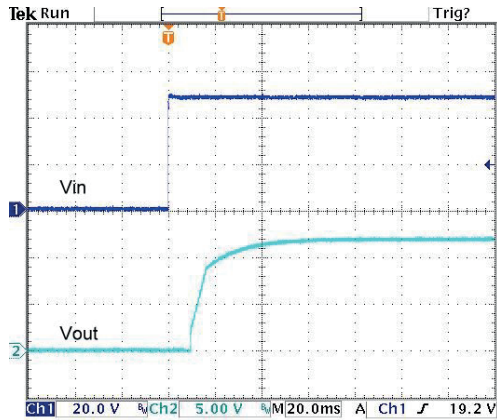

Typical Input Start-Up and Output Rise Characteristic
 $V_{in}=V_{in}(nom)$; Full Load

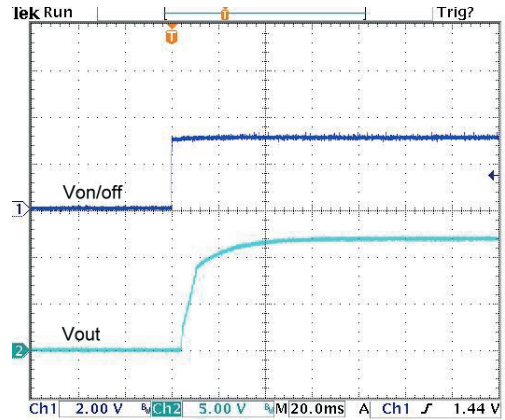

Using ON/OFF Voltage Start-Up and Output Rise Characteristic
 $V_{in}=V_{in}(nom)$; Full Load

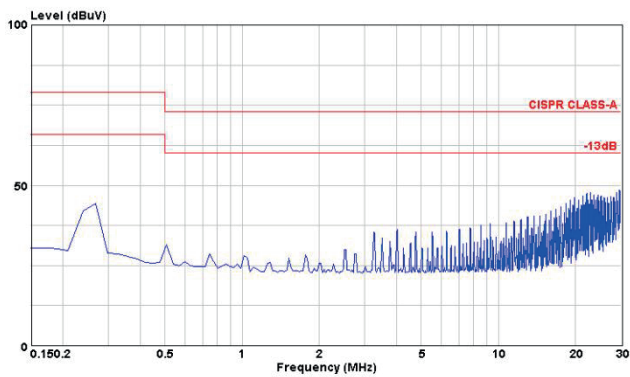

Conduction Emission of EN55022 Class A
 $V_{in}=V_{in}(nom)$; Full Load

POWERBOX Industrial Line
 PED40W Series
 40W 4:1 Single Output
 DC/DC Converter
 Manual

All test conditions are at 25°C. The figures are identical for PED40-48S15W

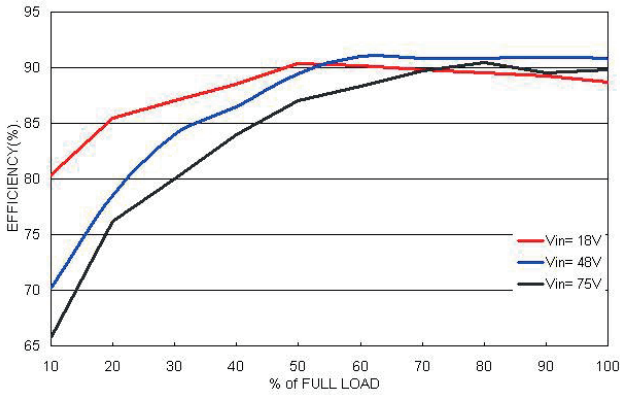

Efficiency versus Output Current
 Vin=Vin(nom)

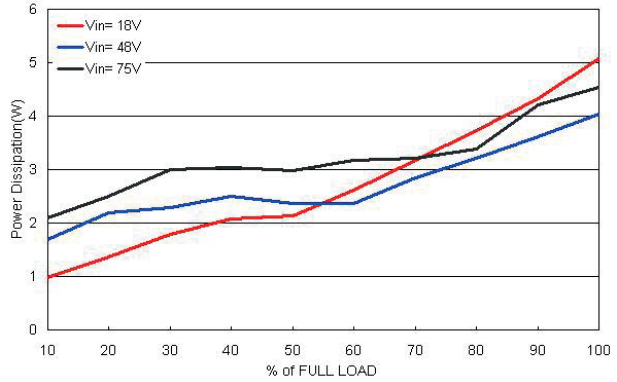

Power dissipation versus Output Current
 Vin=Vin(nom)

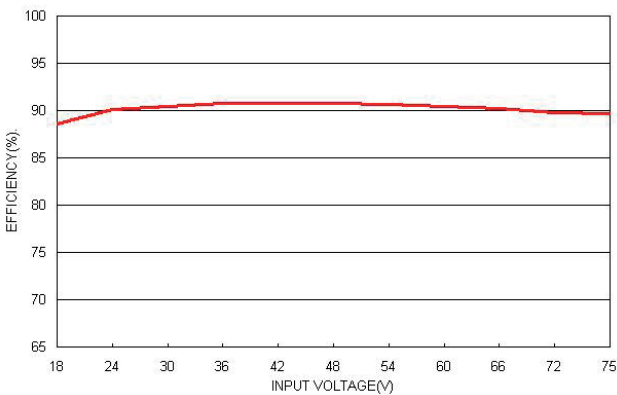

Efficiency versus Input Voltage
 Full Load

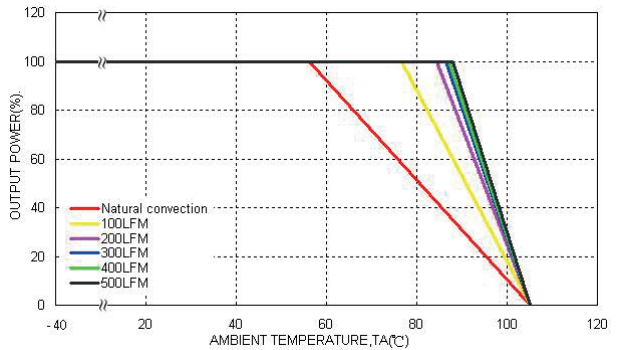

Derating Output Current versus Ambient Temperature and Airflow
 Vin=Vin(nom)

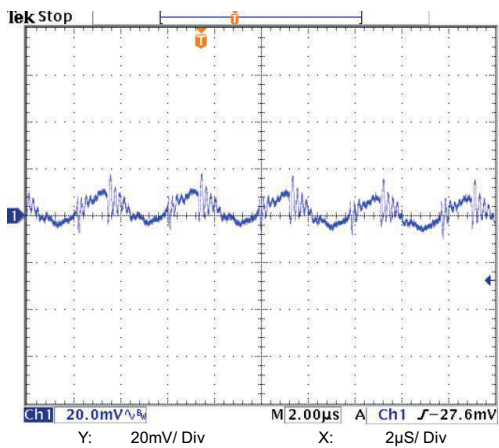

Typical Output Ripple and Noise.
 Vin=Vin(nom); Full Load

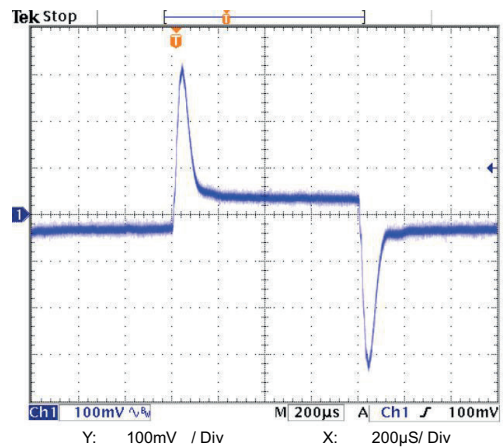

Transient Response to Dynamic Load Change from
 100% to 75% to 100% of Full Load; Vin=Vin(nom)

All test conditions are at 25°C. The figures are identical for PED40-48S15W

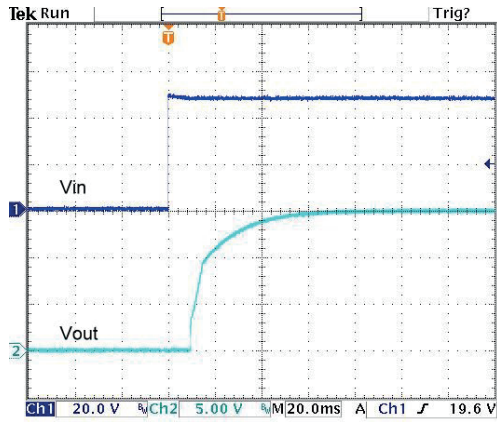

Typical Input Start-Up and Output Rise Characteristic
 $V_{in}=V_{in}(nom)$; Full Load

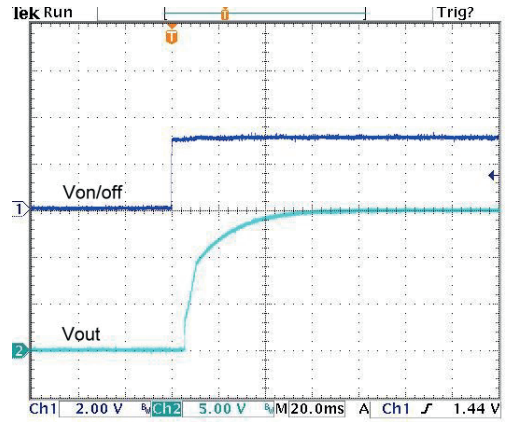

Using ON/OFF Voltage Start-Up and Output Rise Characteristic
 $V_{in}=V_{in}(nom)$; Full Load

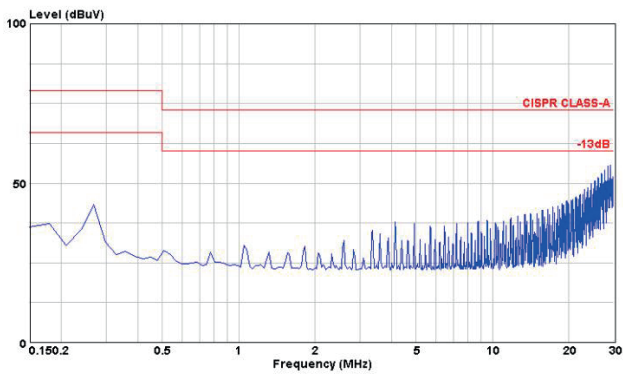

Conduction Emission of EN55022 Class A
 $V_{in}=V_{in}(nom)$; Full Load

POWERBOX Industrial Line
 PED40W Series
 40W 4:1 Single Output
 DC/DC Converter
 Manual

All test conditions are at 25°C. The figures are identical for PED40-48S24W

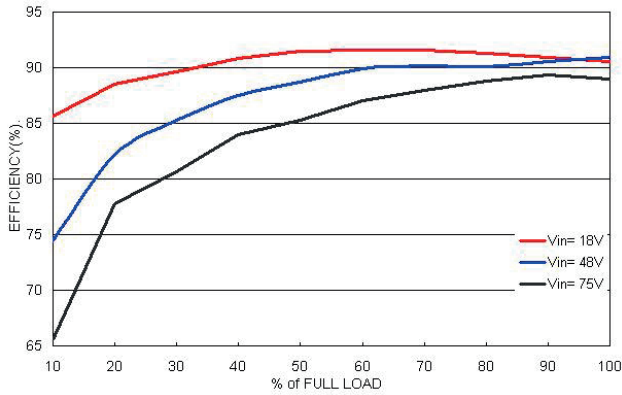

Efficiency versus Output Current
 Vin=Vin(nom)

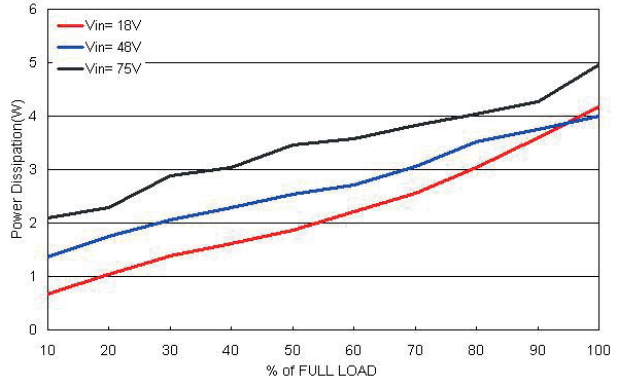

Power dissipation versus Output Current
 Vin=Vin(nom)

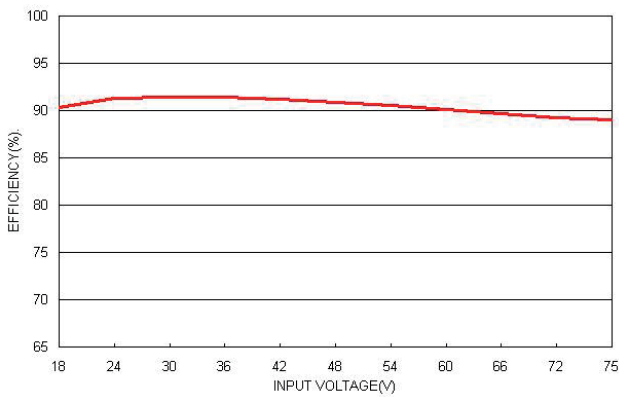

Efficiency versus Input Voltage
 Full Load

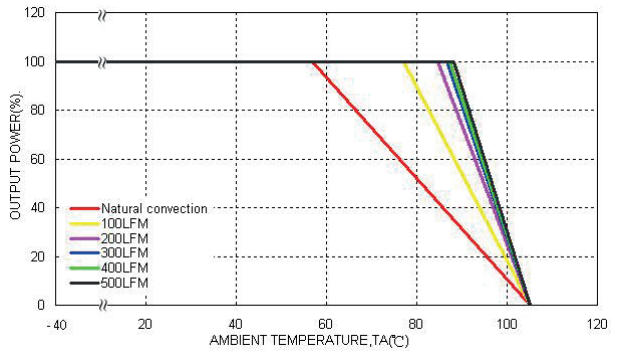

Derating Output Current versus Ambient Temperature and Airflow
 Vin=Vin(nom)

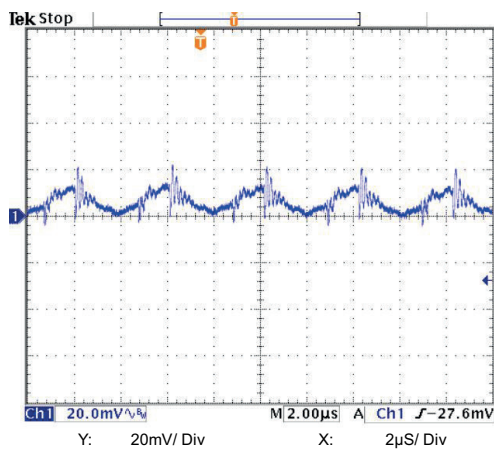

Typical Output Ripple and Noise.
 Vin=Vin(nom); Full Load

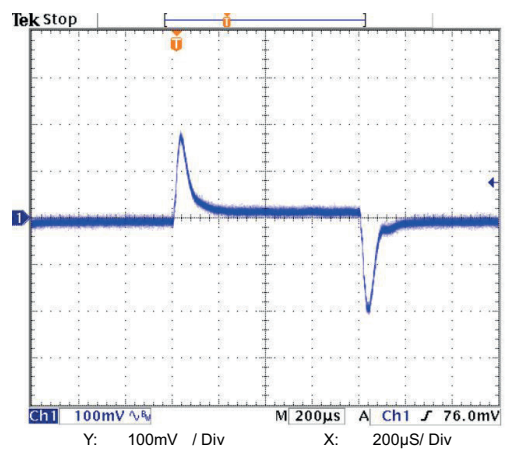

Transient Response to Dynamic Load Change from
 100% to 75% to 100% of Full Load; Vin=Vin(nom)

All test conditions are at 25°C. The figures are identical for PED40-48S24W

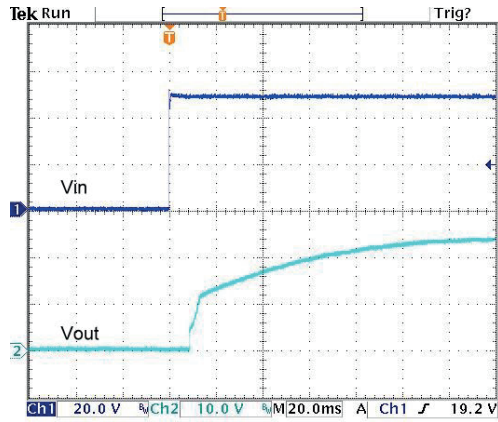

Typical Input Start-Up and Output Rise Characteristic
 $V_{in}=V_{in}(nom)$; Full Load

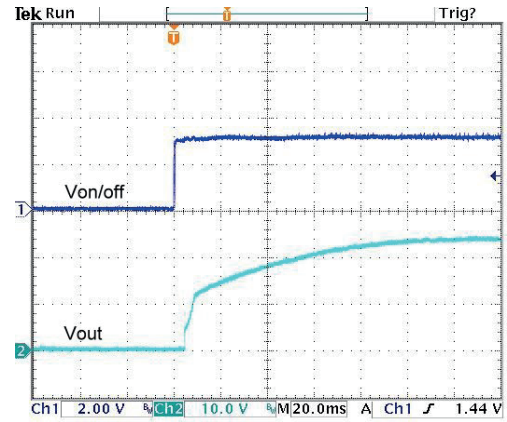

Using ON/OFF Voltage Start-Up and Output Rise Characteristic
 $V_{in}=V_{in}(nom)$; Full Load

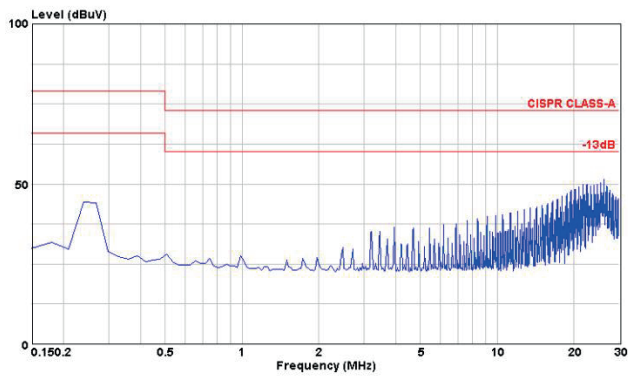

Conduction Emission of EN55022 Class A
 $V_{in}=V_{in}(nom)$; Full Load

POWERBOX Industrial Line
 PED40W Series
 40W 4:1 Single Output
 DC/DC Converter
 Manual

All test conditions are at 25°C. The figures are identical for PED40-110S3P3W

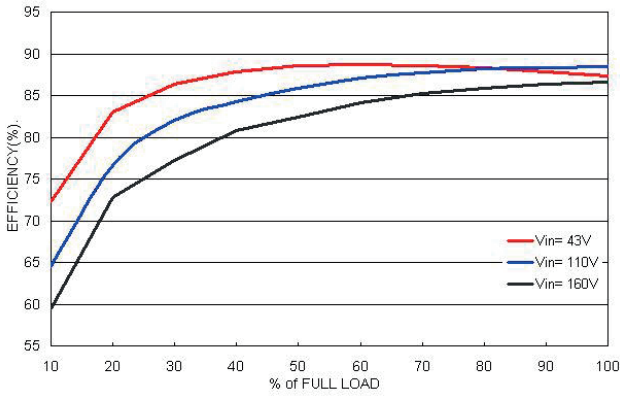

Efficiency versus Output Current
 Vin=Vin(nom)

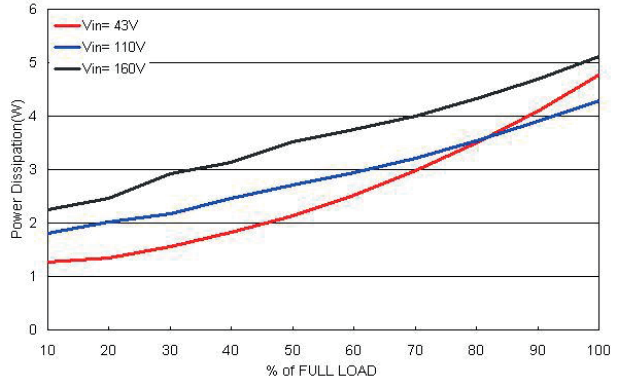

Power dissipation versus Output Current
 Vin=Vin(nom)

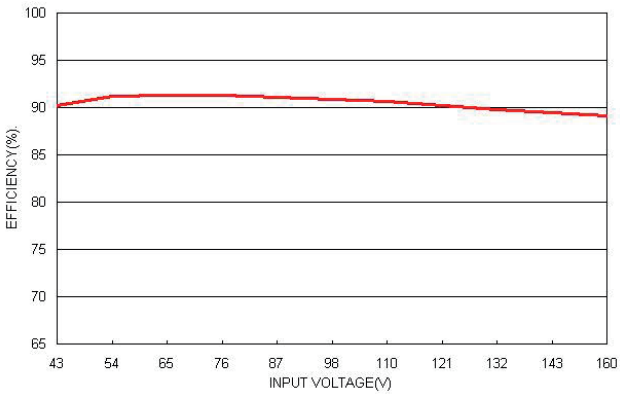

Efficiency versus Input Voltage
 Full Load

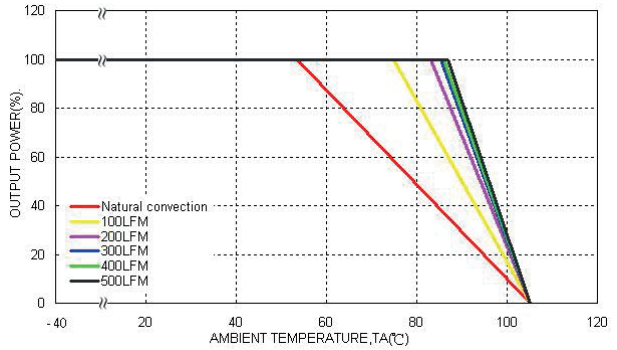

Derating Output Current versus Ambient Temperature and Airflow
 Vin=Vin(nom)

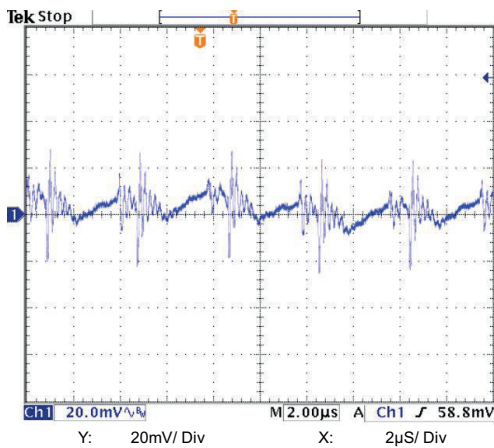

Typical Output Ripple and Noise.
 Vin=Vin(nom); Full Load

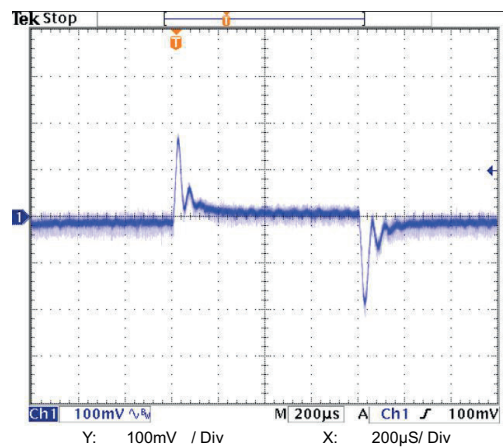

Transient Response to Dynamic Load Change from
 100% to 75% to 100% of Full Load; Vin=Vin(nom)

POWERBOX Industrial Line
 PED40W Series
 40W 4:1 Single Output
 DC/DC Converter
 Manual

All test conditions are at 25°C. The figures are identical for PED40-110S3P3W

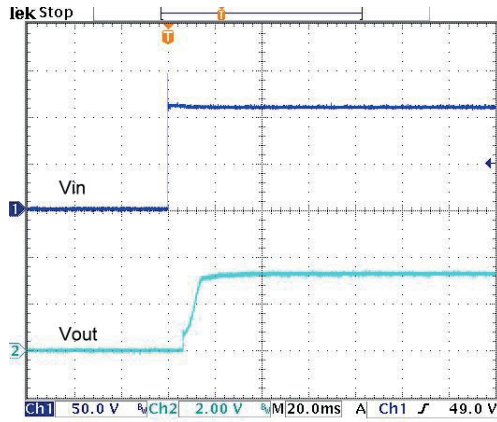

Typical Input Start-Up and Output Rise Characteristic
 $V_{in}=V_{in}(nom)$; Full Load

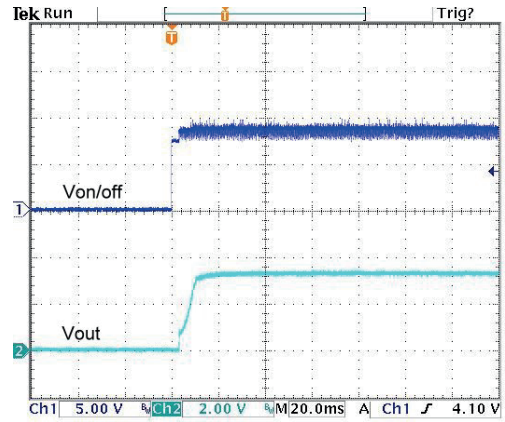

Using ON/OFF Voltage Start-Up and Output Rise Characteristic
 $V_{in}=V_{in}(nom)$; Full Load

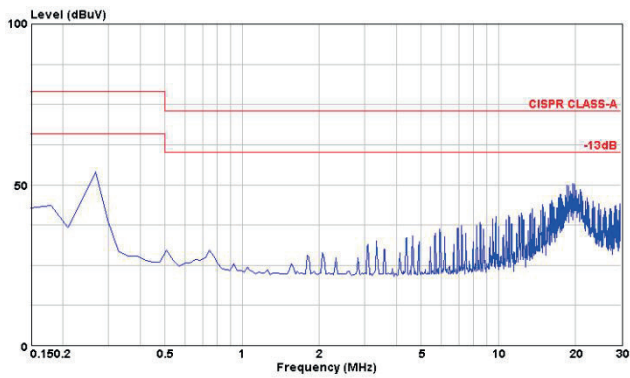

Conduction Emission of EN55022 Class A
 $V_{in}=V_{in}(nom)$; Full Load

POWERBOX Industrial Line
 PED40W Series
 40W 4:1 Single Output
 DC/DC Converter
 Manual

All test conditions are at 25°C. The figures are identical for PED40-110S05W

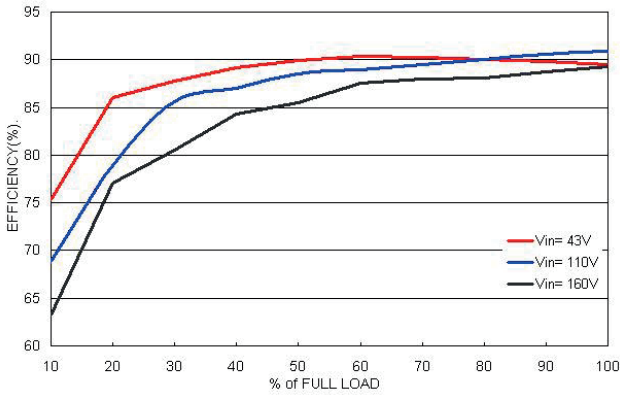

Efficiency versus Output Current
 Vin=Vin(nom)

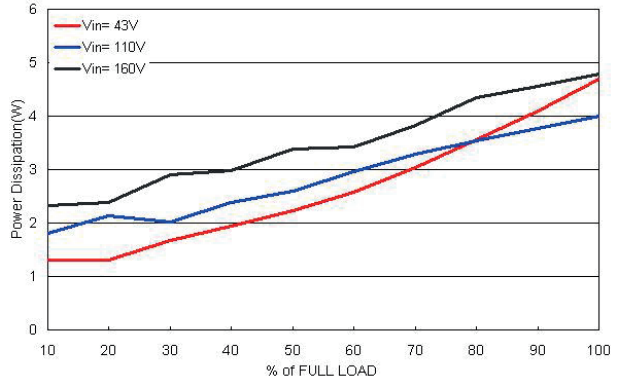

Power dissipation versus Output Current
 Vin=Vin(nom)

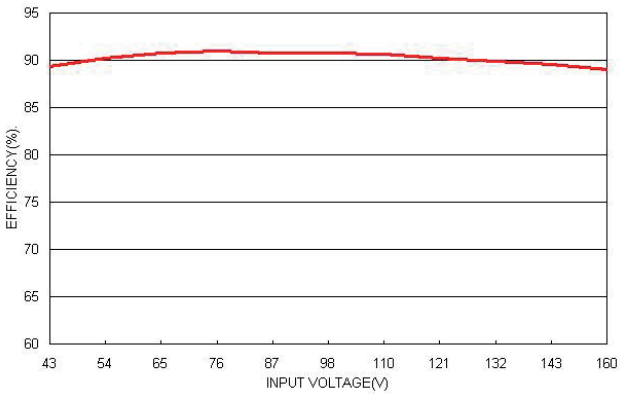

Efficiency versus Input Voltage
 Full Load

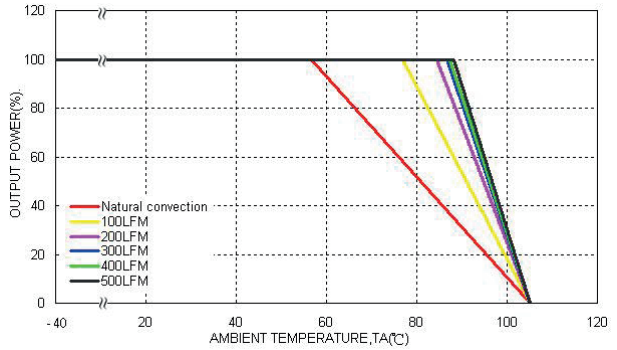

Derating Output Current versus Ambient Temperature and Airflow
 Vin=Vin(nom)

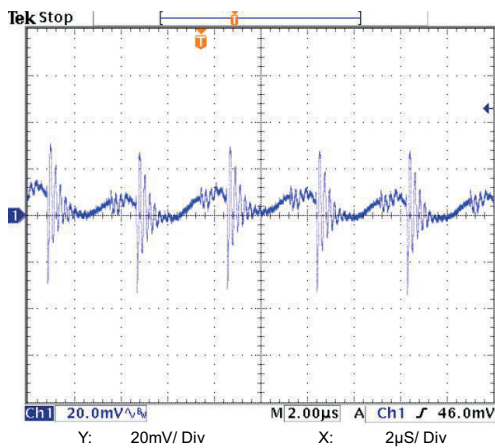

Typical Output Ripple and Noise.
 Vin=Vin(nom); Full Load

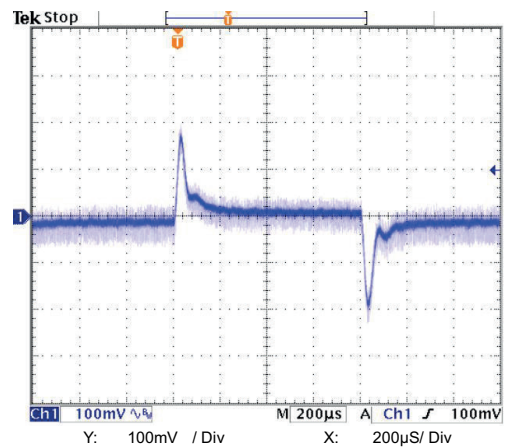

Transient Response to Dynamic Load Change from
 100% to 75% to 100% of Full Load; Vin=Vin(nom)

All test conditions are at 25°C. The figures are identical for PED40-110S05W

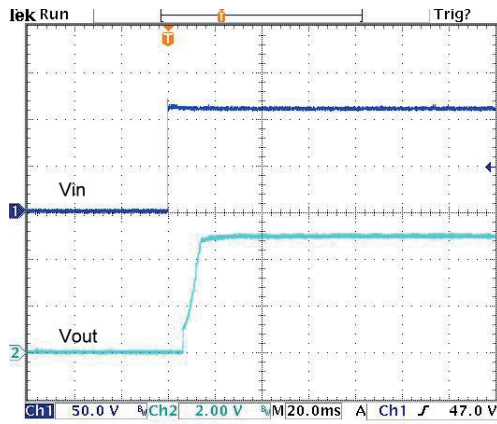

Typical Input Start-Up and Output Rise Characteristic
 $V_{in}=V_{in}(nom)$; Full Load

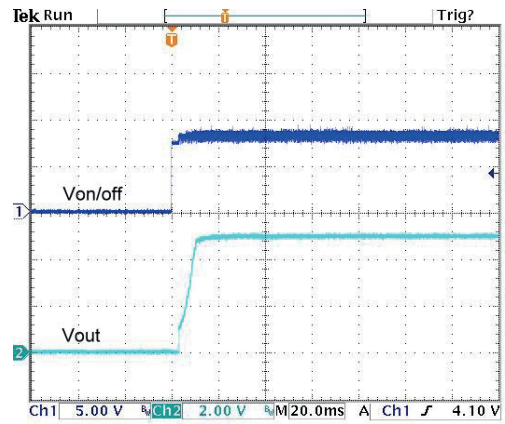

Using ON/OFF Voltage Start-Up and Output Rise Characteristic
 $V_{in}=V_{in}(nom)$; Full Load

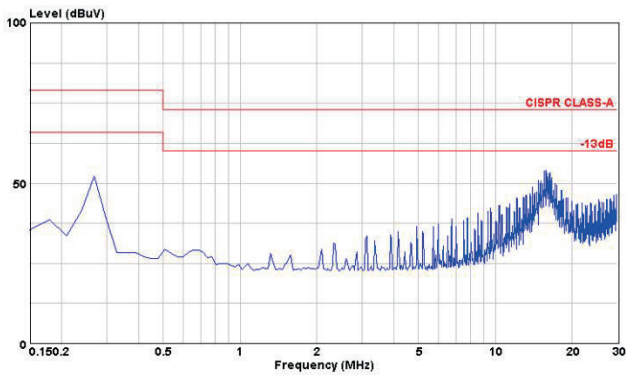

Conduction Emission of EN55022 Class A
 $V_{in}=V_{in}(nom)$; Full Load

POWERBOX Industrial Line
 PED40W Series
 40W 4:1 Single Output
 DC/DC Converter
 Manual

All test conditions are at 25°C. The figures are identical for PED40-110S12W

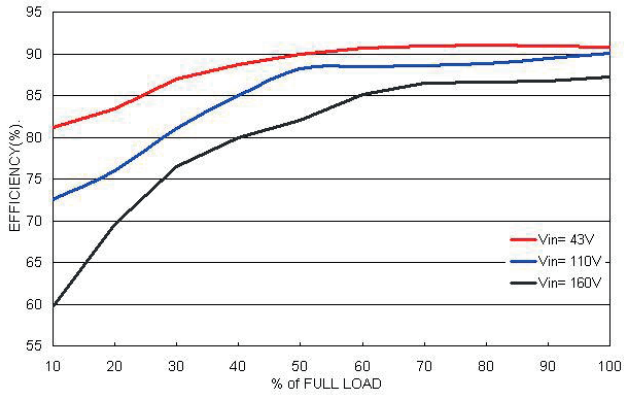

Efficiency versus Output Current
 $V_{in}=V_{in(nom)}$

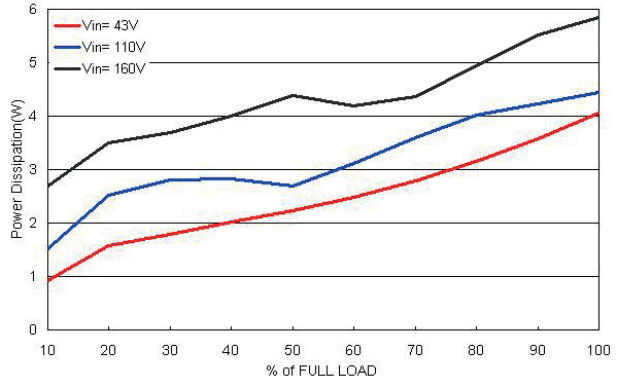

Power dissipation versus Output Current
 $V_{in}=V_{in(nom)}$

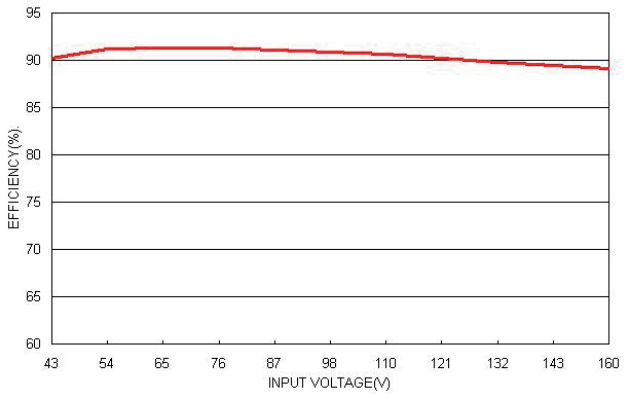

Efficiency versus Input Voltage
 Full Load

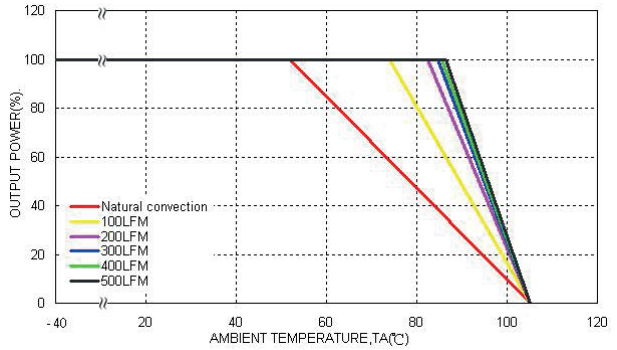

Derating Output Current versus Ambient Temperature and Airflow
 $V_{in}=V_{in(nom)}$

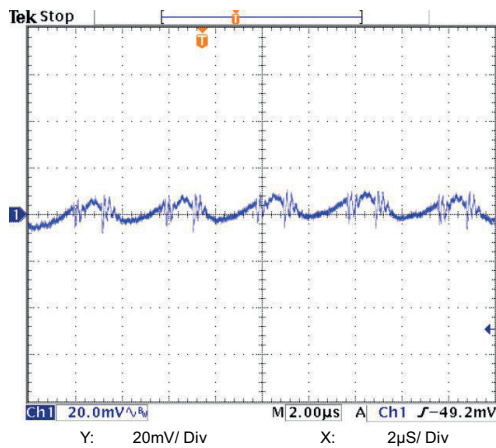

Typical Output Ripple and Noise.
 $V_{in}=V_{in(nom)}$; Full Load

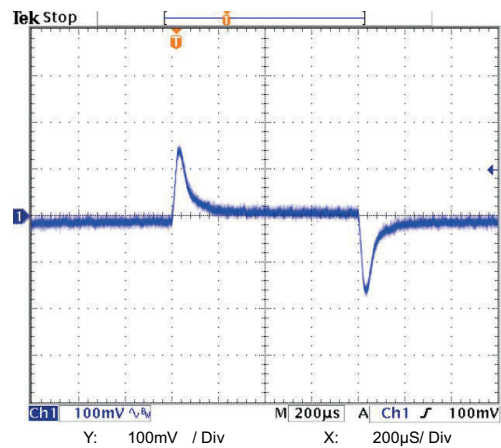

Transient Response to Dynamic Load Change from
 100% to 75% to 100% of Full Load; $V_{in}=V_{in(nom)}$

All test conditions are at 25°C. The figures are identical for PED40-110S12W

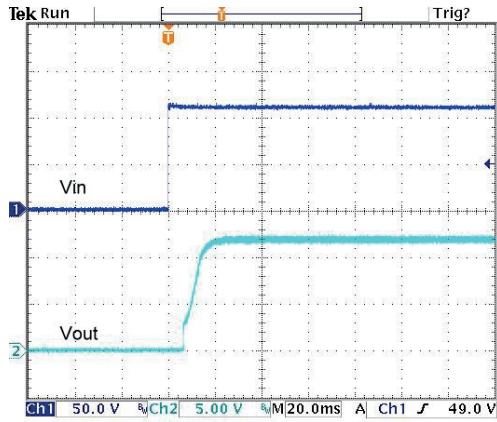

Typical Input Start-Up and Output Rise Characteristic
 $V_{in}=V_{in}(nom)$; Full Load

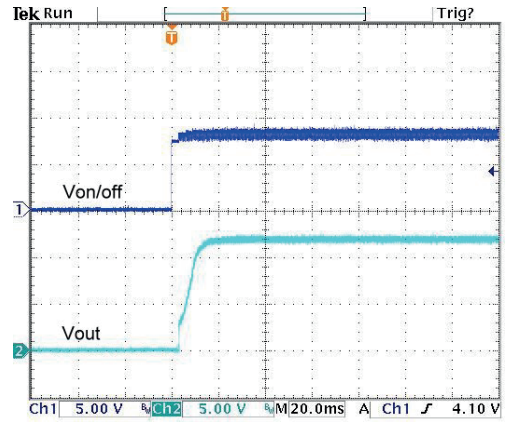

Using ON/OFF Voltage Start-Up and Output Rise Characteristic
 $V_{in}=V_{in}(nom)$; Full Load

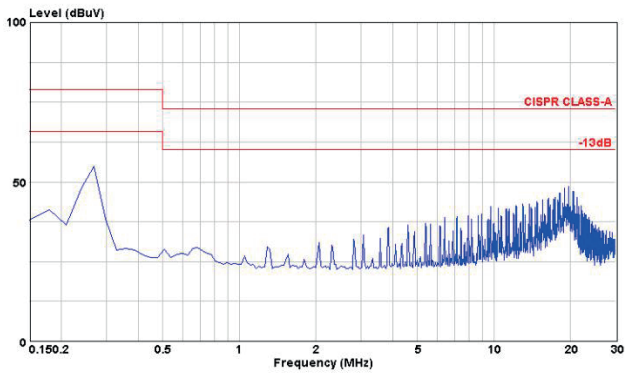

Conduction Emission of EN55022 Class A
 $V_{in}=V_{in}(nom)$; Full Load

POWERBOX Industrial Line
 PED40W Series
 40W 4:1 Single Output
 DC/DC Converter
 Manual

All test conditions are at 25°C. The figures are identical for PED40-110S15W

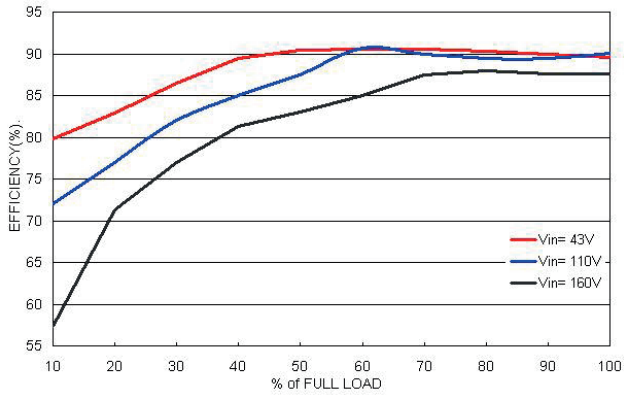

Efficiency versus Output Current
 Vin=Vin(nom)

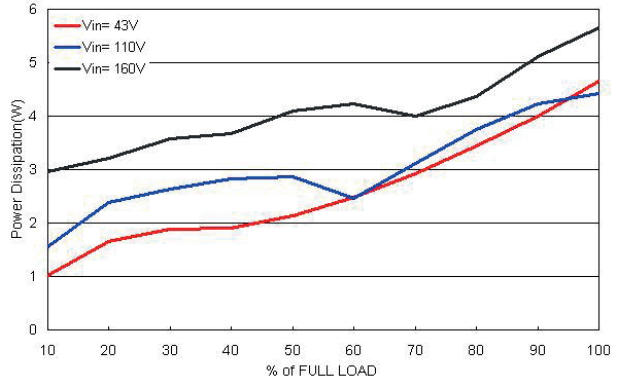

Power dissipation versus Output Current
 Vin=Vin(nom)

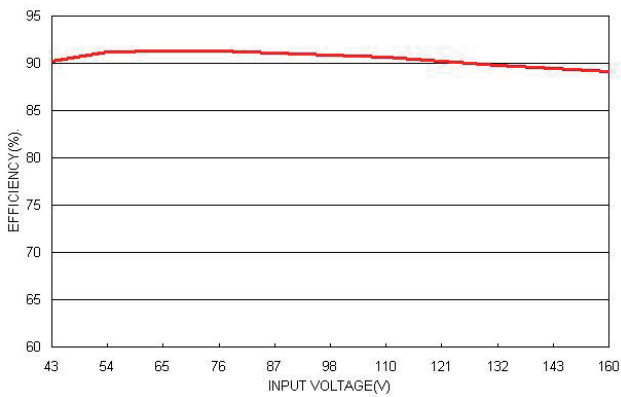

Efficiency versus Input Voltage
 Full Load

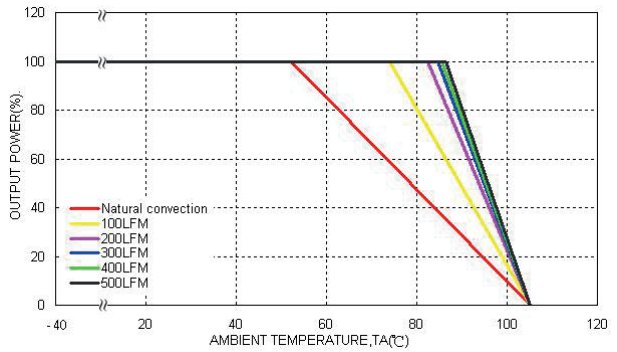

Derating Output Current versus Ambient Temperature and Airflow
 Vin=Vin(nom)

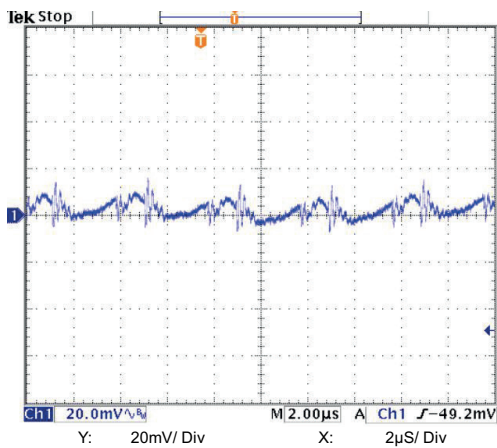

Typical Output Ripple and Noise.
 Vin=Vin(nom); Full Load

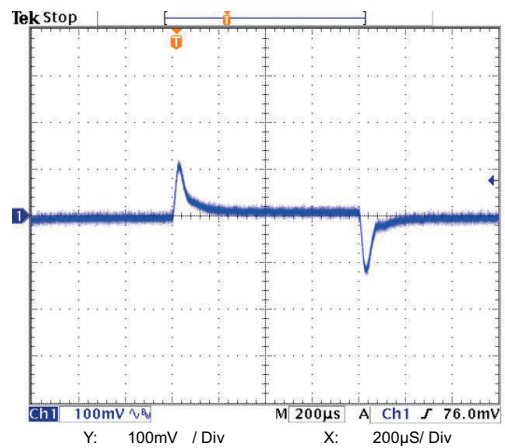

Transient Response to Dynamic Load Change from
 100% to 75% to 100% of Full Load; Vin=Vin(nom)

All test conditions are at 25°C. The figures are identical for PED40-110S15W

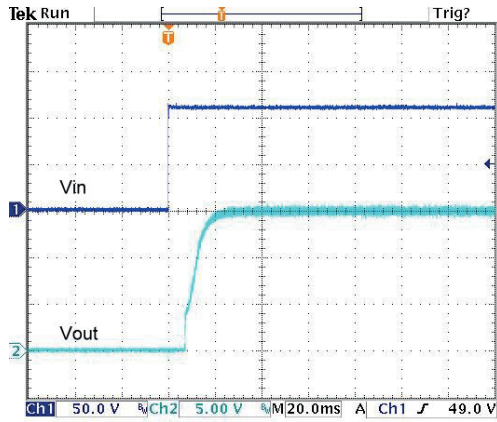

Typical Input Start-Up and Output Rise Characteristic
 $V_{in}=V_{in}(nom)$; Full Load

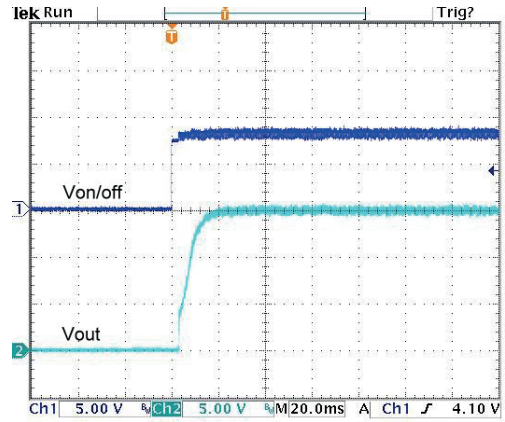

Using ON/OFF Voltage Start-Up and Output Rise Characteristic
 $V_{in}=V_{in}(nom)$; Full Load

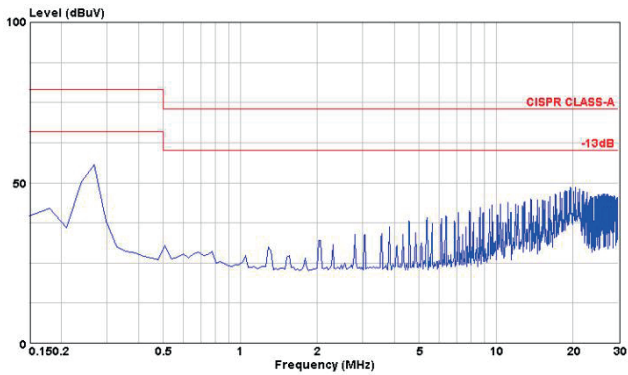

Conduction Emission of EN55022 Class A
 $V_{in}=V_{in}(nom)$; Full Load

POWERBOX Industrial Line
 PED40W Series
 40W 4:1 Single Output
 DC/DC Converter
 Manual

All test conditions are at 25°C. The figures are identical for PED40-110S24W

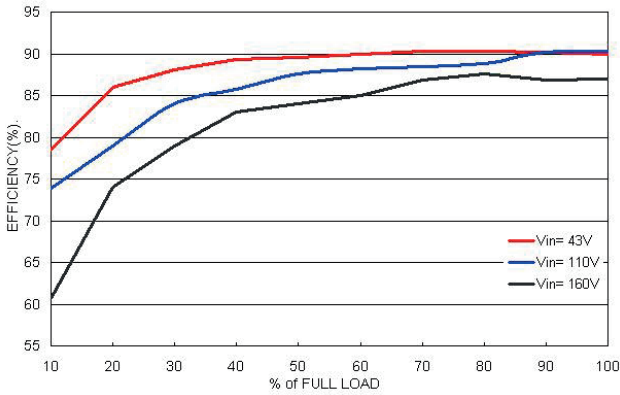

Efficiency versus Output Current
 $V_{in}=V_{in(nom)}$

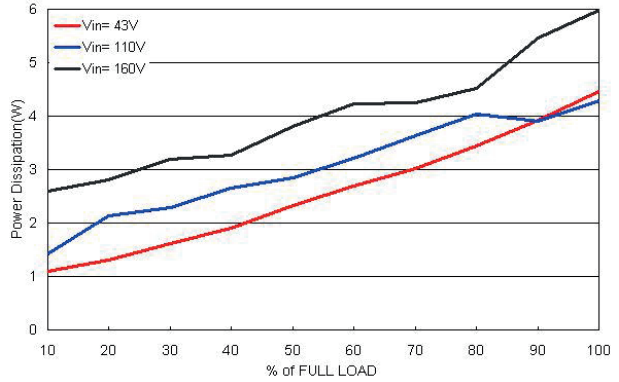

Power dissipation versus Output Current
 $V_{in}=V_{in(nom)}$

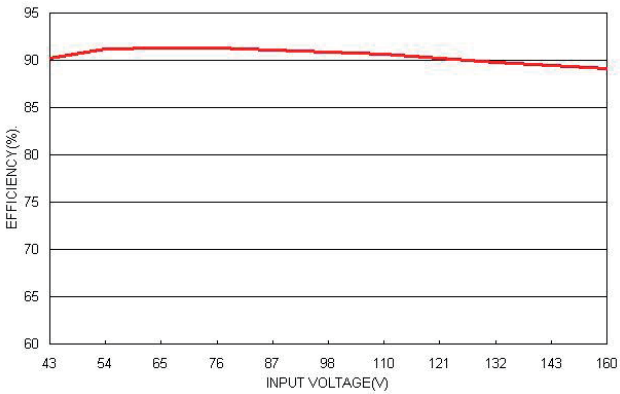

Efficiency versus Input Voltage
 Full Load

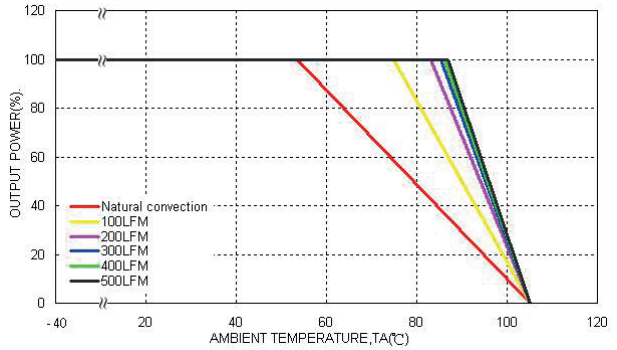

Derating Output Current versus Ambient Temperature and Airflow
 $V_{in}=V_{in(nom)}$

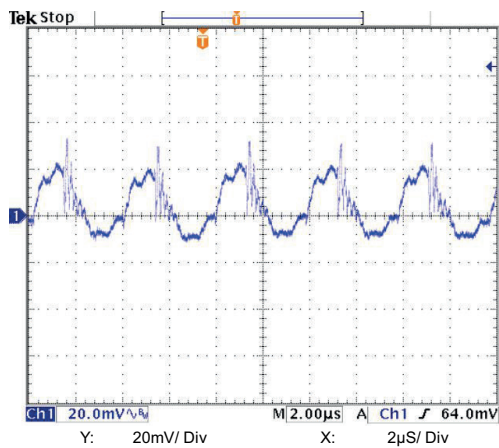

Typical Output Ripple and Noise.
 $V_{in}=V_{in(nom)}$; Full Load

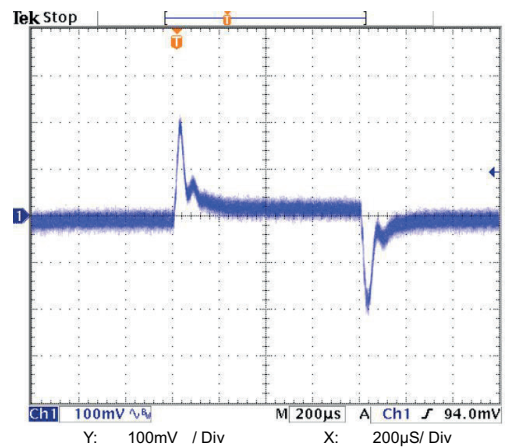

Transient Response to Dynamic Load Change from
 100% to 75% to 100% of Full Load; $V_{in}=V_{in(nom)}$

All test conditions are at 25°C. The figures are identical for PED40-110S24W

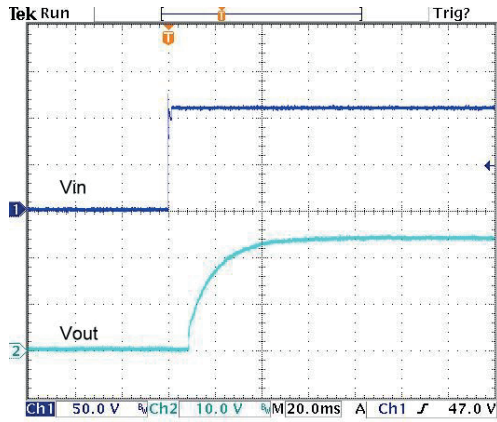

Typical Input Start-Up and Output Rise Characteristic
 $V_{in}=V_{in}(nom)$; Full Load

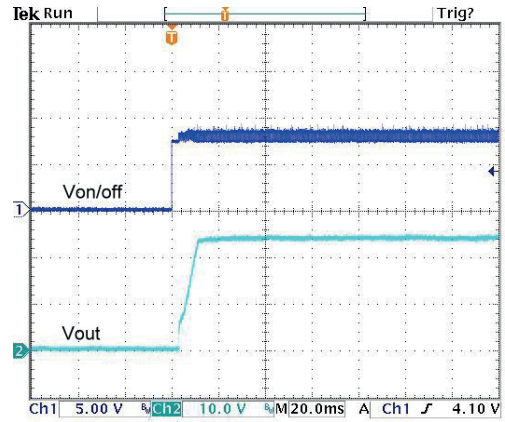

Using ON/OFF Voltage Start-Up and Output Rise Characteristic
 $V_{in}=V_{in}(nom)$; Full Load

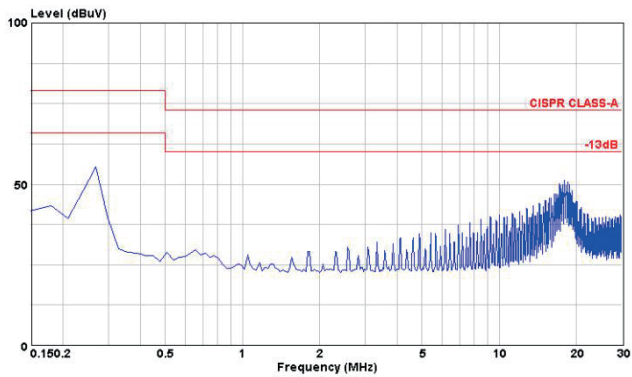

Conduction Emission of EN55022 Class A
 $V_{in}=V_{in}(nom)$; Full Load

Test Configurations

Input Reflected-Ripple Current Measurement Setup

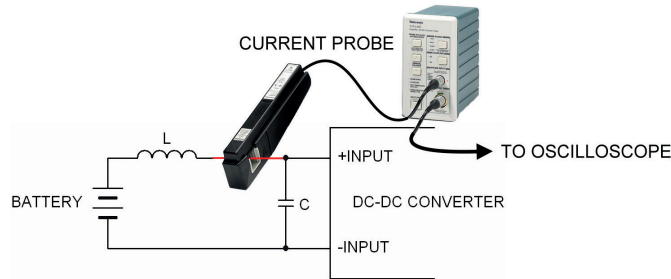

PED40-24S□□W / PED40-48S□□W

Component	Value	Voltage	Reference
L	15μH	----	----
C	220μF	100V	Aluminum Electrolytic Capacitor

PED40-110S□□W

Component	Value	Voltage	Reference
L	8.2μH	----	----
C	22μF	400V	Aluminum Electrolytic Capacitor

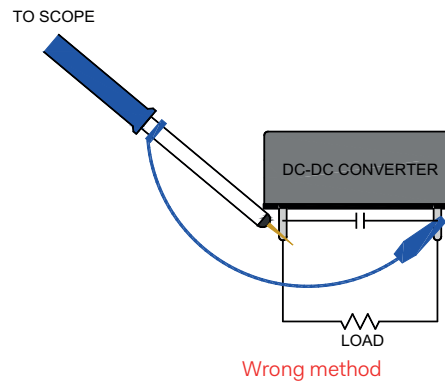
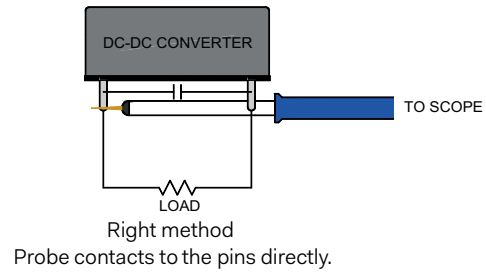

Peak-to-peak Output Ripple & Noise Measurement Setup

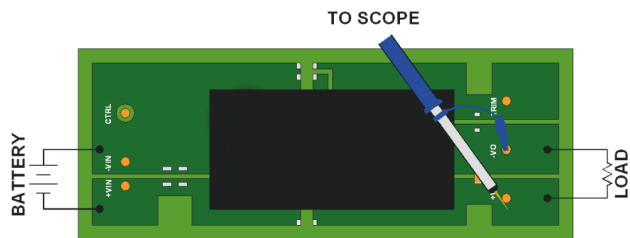
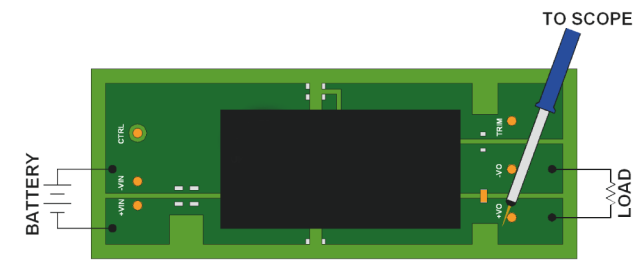
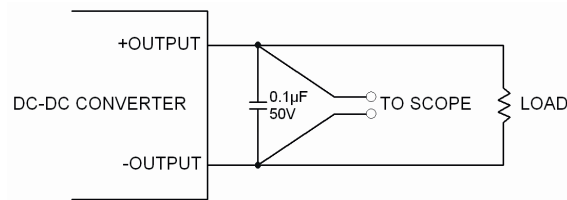

Output Voltage and Efficiency Measurement Setup

Voltage meters should connect to input or output terminals directly or voltage drop of contact and distribution losses causes the measurement is not correct.

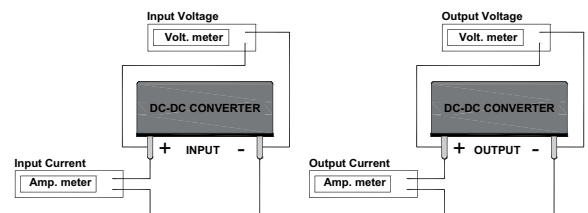
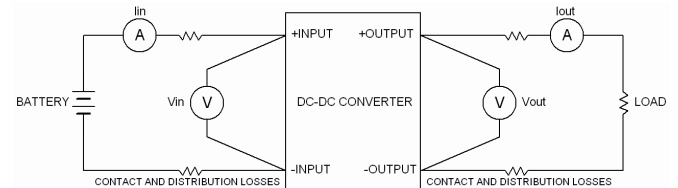

$$\text{Output Voltage Accuracy} = \frac{V_{out} - V_{out,typ}}{V_{out,typ}} \times 100\%$$

$$\text{Line Regulation} = \text{Max} \left(\frac{V_{out(Low-Line)} - V_{out(Nom-Line)}}{V_{out(Nom-Line)}} \times 100\%, \frac{V_{out(High-Line)} - V_{out(Nom-Line)}}{V_{out(Nom-Line)}} \times 100\% \right)$$

$$\text{Load Regulation} = \frac{V_{out(MinLoad)} - V_{out(FullLoad)}}{V_{out(FullLoad)}} \times 100\%$$

$$\text{Efficiency} = \frac{V_{out} \times I_{out}}{V_{in} \times I_{in}} \times 100\%$$

POWERBOX Industrial Line
 PED40W Series
 40W 4:1 Single Output
 DC/DC Converter
 Manual

EMC Considerations
 EMS Test Setup

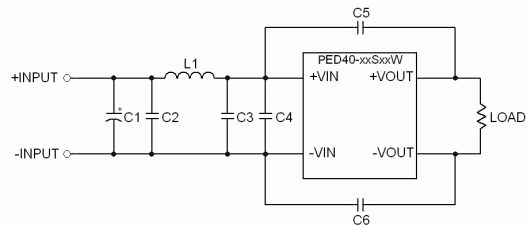

Suggested schematic for EN 55011 and EN 55022 conducted emission Class A limits

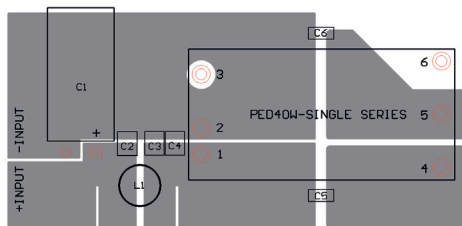

Recommended layout with input filter; Top layer

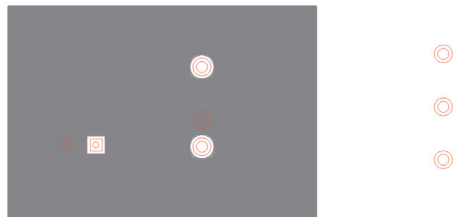

Recommended layout with input filter; Bottom layer

To meet conducted emissions EN55022 Class A needed the following components:

PED40-24S□□W

Component	Value	Voltage	Reference
C2, C4	6.8 μ F	50V	1812 MLCC
C5, C6	1000pF	2KV	1206 MLCC
L1	2.2 μ H	----	SMD Inductor; P/N: PMT-097

PED40-48S□□W

Component	Value	Voltage	Reference
C2, C4	4.7 μ F	100V	1812 MLCC
C5, C6	1000pF	2KV	1206 MLCC
L1	10 μ H	----	SMD Inductor; P/N: PMT-070

PED40-110S□□W

Component	Value	Voltage	Reference
C1	68 μ F	200V	Rubycon BXF-series
C3, C4	1 μ F	250V	1812 MLCC
C5, C6	1000pF	2KV	1206 MLCC
L1	22 μ H	----	SMD Inductor; P/N: PMT-098

POWERBOX Industrial Line
 PED40W Series
 40W 4:1 Single Output
 DC/DC Converter
 Manual

The common mode choke and inductors have been defined as following:

PMT-070

Inductance:	10 μ H \pm 20%
Impedance:	40m Ω
Rated current:	2.6A

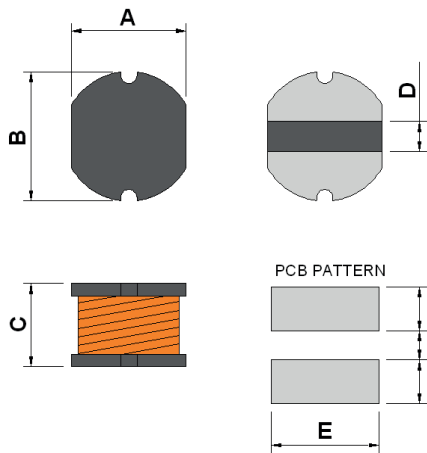

A	B	C	D	E	G	H
7.0 \pm 0.3	7.8 \pm 0.3	5.0 \pm 0.5	2.1 REF	7.50	2.00	3.00

PMT-097

Inductance:	2.2 μ H \pm 20%
Impedance:	12m Ω
Rated Current:	11A

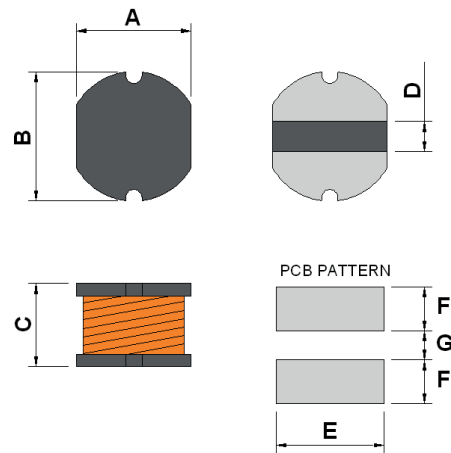

A	B	C	D	E	G	H
7.0 \pm 0.3	7.8 \pm 0.3	5.0 \pm 0.5	2.1REF	7.50	2.00	3.00

PMT-097

Inductance:	2.2 μ H \pm 20%
Impedance:	12m Ω
Rated current:	11A

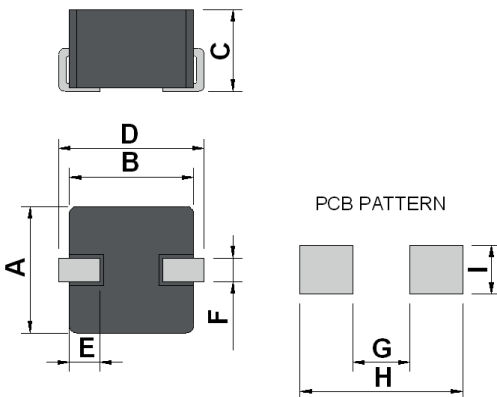

A	B	C	D	E
6.5 \pm 0.3	6.5 \pm 0.3	4.2,max.	7.6,max.	1.6 \pm 0.3

F	G	H	I
1.2 \pm 0.3	3	8.5	2.5

The PED40W series can meet Fast Transient EN61000-4-4 and Surge EN61000-4-5 performance criteria A with external components connected to the input terminals of the module. Please see the following schematics as below.

Fast Transient

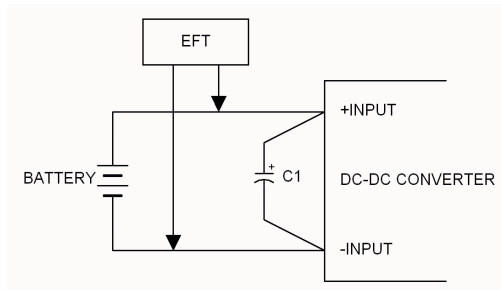

PED40-24S□□W

Component	Value	Voltage	Reference
C1	220μF	100V	Nippon chemi-con KY-series

PED40-48S□□W

Component	Value	Voltage	Reference
C1	220μF	100V	Nippon chemi-con KY-series

PED40-110S□□W

Component	Value	Voltage	Reference
C1	68μF	200V	Rubycon BXF-series

Surge

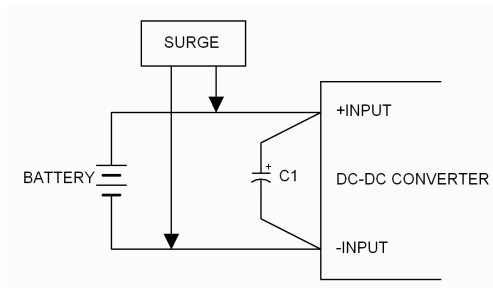

PED40-24S□□W

Component	Value	Voltage	Reference
C1	330μF	100V	Nippon chemi-con KY-series

PED40-48S□□W

Component	Value	Voltage	Reference
C1	220μF	100V	Nippon chemi-con KY-series

PED40-110S□□W

Component	Value	Voltage	Reference
C1	68μF	200V	Rubycon BXF-series

Output Voltage Adjustment

Output voltage set point adjustment allows the user to increase or decrease the output voltage set point of the module. This is accomplished by connecting an external resistor between the TRIM pin and either the +OUTPUT or -OUTPUT pins. With an external resistor between the TRIM and -OUTPUT pin, the output voltage set point increases. With an external resistor between the TRIM and +OUTPUT pin, the output voltage set point decreases. The external TRIM resistor needs to be at least 1/16W of rated power.

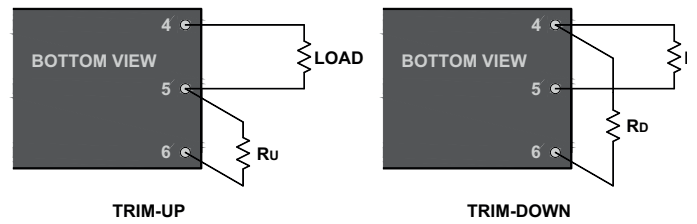

Output voltage adjustment configurations

POWERBOX Industrial Line
 PED40W Series
 40W 4:1 Single Output
 DC/DC Converter
 Manual

Trim Table

PED40-□□S3P3W

Trim-Up	(%)	1	2	3	4	5	6	7	8	9	10
Vout	(V)	3.333	3.366	3.399	3.432	3.465	3.498	3.531	3.564	3.597	3.630
RU	(KΩ)	57.93	26.165	15.577	10.283	7.106	4.988	3.476	2.341	1.459	0.753

Trim-Down	(%)	1	2	3	4	5	6	7	8	9	10
Vout	(V)	3.267	3.234	3.201	3.168	3.135	3.102	3.069	3.036	3.003	2.970
RD	(KΩ)	69.47	31.235	18.49	12.117	8.294	5.745	3.924	2.559	1.497	0.647

PED40-□□S05W

Trim-Up	(%)	1	2	3	4	5	6	7	8	9	10
Vout	(V)	5.050	5.100	5.150	5.200	5.250	5.300	5.350	5.400	5.450	5.500
RU	(KΩ)	36.57	16.58	9.917	6.585	4.586	3.253	2.302	1.588	1.032	0.588

Trim-Down	(%)	1	2	3	4	5	6	7	8	9	10
Vout	(V)	4.950	4.900	4.850	4.800	4.750	4.700	4.650	4.600	4.550	4.500
RD	(KΩ)	45.533	20.612	12.306	8.152	5.66	3.999	2.812	1.922	1.23	0.676

PED40-□□S12W

Trim-Up	(%)	1	2	3	4	5	6	7	8	9	10
Vout	(V)	12.120	12.240	12.360	12.480	12.600	12.720	12.840	12.960	13.080	13.200
RU	(KΩ)	367.91	165.95	98.636	64.977	44.782	31.318	21.701	14.488	8.879	4.391

Trim-Down	(%)	1	2	3	4	5	6	7	8	9	10
Vout	(V)	11.880	11.760	11.640	11.520	11.400	11.280	11.160	11.040	10.920	10.800
RD	(KΩ)	460.99	207.95	123.6	81.423	56.118	39.249	27.199	18.162	11.132	5.509

PED40-□□S15W

Trim-Up	(%)	1	2	3	4	5	6	7	8	9	10
Vout	(V)	15.150	15.300	15.450	15.600	15.750	15.900	16.050	16.200	16.350	16.500
RU	(KΩ)	419.81	199.91	126.60	89.95	67.96	53.30	42.83	34.98	28.87	23.98

Trim-Up	(%)	11	12	13	14	15	16	17	18	19	20
Vout	(V)	16.650	16.800	16.950	17.100	17.250	17.400	17.550	17.700	17.850	18.000
RU	(KΩ)	19.98	16.65	13.83	11.42	9.32	7.49	5.87	4.43	3.15	1.99

Trim-Down	(%)	1	2	3	4	5	6	7	8	9	10
Vout	(V)	14.850	14.700	14.550	14.400	14.250	14.000	13.750	13.500	13.250	13.000
RD	(KΩ)	284.89	128.68	76.61	50.58	34.96	24.55	17.11	11.53	7.19	3.72

PED40-□□S24W

Trim-Up	(%)	1	2	3	4	5	6	7	8	9	10
Vout	(V)	24.240	24.480	24.720	24.960	25.200	25.440	25.680	25.920	26.160	26.400
RU	(KΩ)	1275.2	606.60	383.73	272.30	205.44	160.87	129.03	105.15	86.58	71.72

Trim-Up	(%)	11	12	13	14	15	16	17	18	19	20
Vout	(V)	26.640	26.880	27.120	27.360	27.600	27.840	28.080	28.320	28.560	28.800
RU	(KΩ)	59.56	49.43	40.86	33.51	27.15	21.57	16.66	12.29	8.38	4.86

Trim-Down	(%)	1	2	3	4	5	6	7	8	9	10
Vout	(V)	23.760	23.520	23.280	23.040	22.800	22.560	22.320	22.080	21.840	21.600
RD	(KΩ)	838.15	376.78	222.98	146.09	99.95	69.19	47.22	30.74	17.93	7.68

Input Source Impedance

The power module should be connected to a low impedance input source. Highly inductive source impedance can affect the stability of the power module. Input external L-C filter is recommended to minimize input reflected ripple current. The inductor is simulated source impedance of $15\mu\text{H}$ and capacitor is Nippon chemi-con KY series $220\mu\text{F}/100\text{V}$. The capacitor must as close as possible to the input terminals of the power module for lower impedance.

Output Over Current Protection

When excessive output currents occur in the system, circuit protection is required on all power supplies. Normally, overload current is maintained at approximately 150 percent of rated current for PED40W SERIES. Hiccup-mode is a method of operation in a power supply whose purpose is to protect the power supply from being damaged during an over-current fault condition. It also enables the power supply to restart when the fault is removed. There are other ways of protecting the power supply when it is over-loaded, such as the maximum current limiting or current fold-back methods.

One of the problems resulting from over current is that excessive heat may be generated in power devices; especially MOSFET and Schottky diodes and the temperature of those devices may exceed their specified limits. A protection mechanism has to be used to prevent those power devices from being damaged.

The operation of hiccup is as follows. When the current sense circuit sees an over-current event, the controller shuts off the power supply for a given time and then tries to start up the power supply again. If the over-load condition has been removed, the power supply will start up and operate normally; otherwise, the controller will see another over-current event and shut off the power supply again, repeating the previous cycle. Hiccup operation has none of the drawbacks of the other two protection methods, although its circuit is more complicated because it requires a timing circuit. The excess heat due to overload lasts for only a short duration in the hiccup cycle, hence the junction temperature of the power devices is much lower.

The hiccup operation can be done in various ways. For example, one can start hiccup operation any time an over-current event is detected; or prohibit hiccup during a designated start-up is usually larger than during normal operation and it is easier for an over-current event is detected; or prohibit hiccup during a designated start-up interval (usually a few milliseconds). The reason for the latter operation is that during start-up, the power supply needs to provide extra current to charge up the output capacitor. Thus the current demand during start-up is usually larger than during normal operation and it is easier for an over-current event to occur. If the power supply starts to hiccup once there is an over-current, it might never start up successfully. Hiccup mode protection will give the best protection for a power supply against over current situations, since it will limit the average current to the load at a low level, so reducing power dissipation and case temperature in the power devices.

Short Circuitry Protection

Hiccup and auto-recovery mode.

During short circuit, converter still shut down. The average current during this condition will be very low and the device can be safety in this condition.

Output Over Voltage Protection

The output over-voltage protection consists of output Zener diode that monitors the voltage on the output terminals. If the voltage on the output terminals exceeds the over-voltage protection threshold, then the Zener diode clamps the output voltage.

Thermal Considerations

The power module operates in a variety of thermal environments. However, sufficient cooling should be provided to help ensure reliable operation of the unit. Heat is removed by conduction, convection, and radiation to the surrounding Environment. Proper cooling can be verified by measuring the point as the figure below. The temperature at this location should not exceed 105°C . When Operating, adequate cooling must be provided to maintain the test point temperature at or below 105°C . Although the maximum point Temperature of the power modules is 105°C , you can limit this Temperature to a lower value for extremely high reliability.

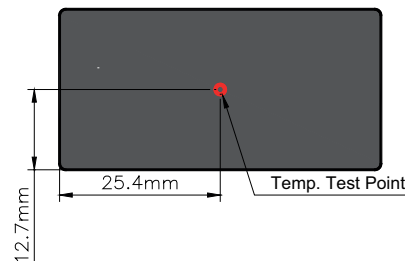

Heat-Sink Considerations

Equip heat-sink for lower temperature and higher reliability of the module. There are two types for choosing.

Suffix - HC : Heat-sink + Clamp
 P/N: 7G-0020C-F.

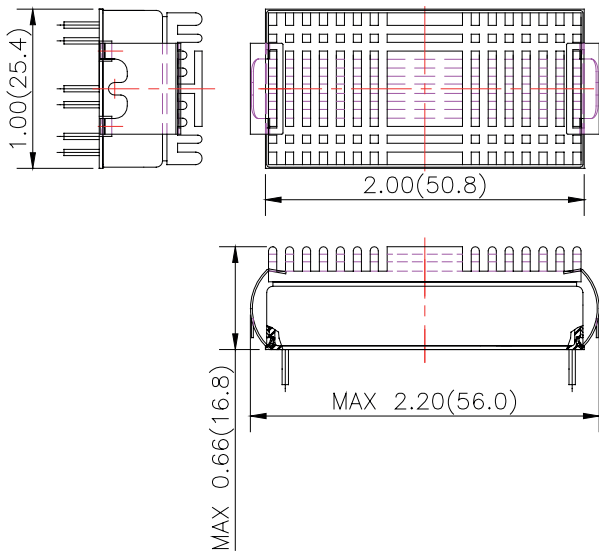

Remote On/Off Control

With no suffix, the positive logic remote ON/OFF control circuit is included. Ex.: PED40-24S05W. Turns the module ON during logic High on the On/Off pin and turns OFF during logic Low. The On/Off pin is an open collector/drain logic input signal ($V_{ON/OFF}$) that referenced to GND. If not using the remote on/off feature, please open circuit between on/off pin and -input pin to turn the module on.

With suffix -N, the negative logic remote ON/OFF control circuit is included. Ex.: PED40-24S05W-N. Turns the module ON during logic Low on the On/Off pin and turns OFF during logic High. The On/Off pin is an open collector/drain logic input signal ($V_{ON/OFF}$) that referenced to GND. If not using the remote on/off feature, please short circuit between on/off pin and -input pin to turn the module on.

Remote ON/OFF Implementation

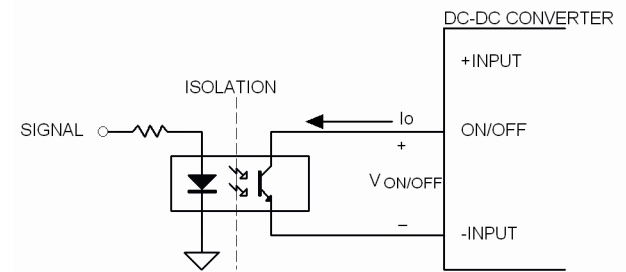

Isolated-Closure Remote ON/OFF

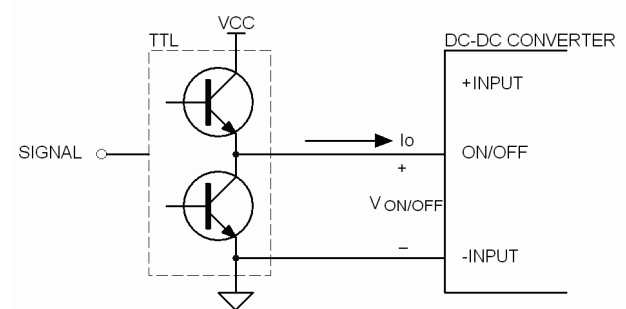

Level Control Using TTL Output

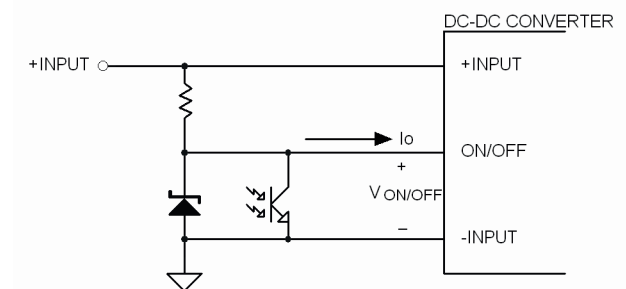

Level Control Using Line Voltage

Mechanical Data

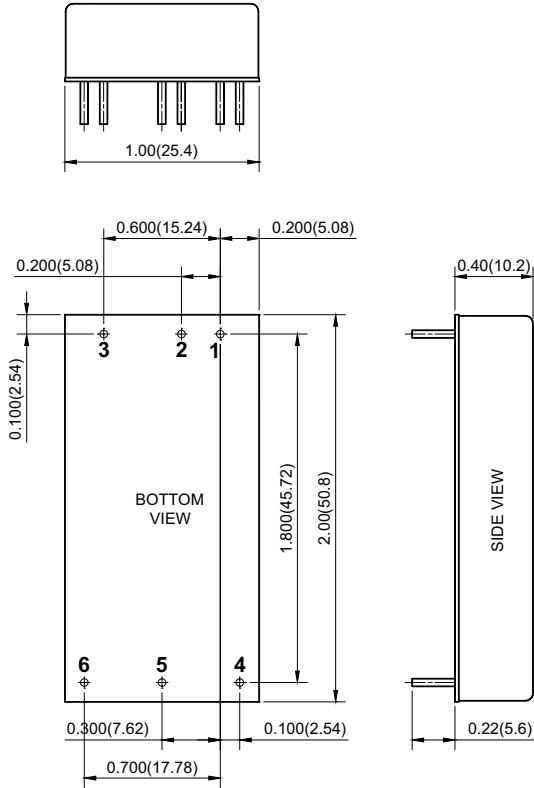

1. All dimensions in Inches (mm)
Tolerance: X.XX±0.02 (X.X±0.5)
X.XXX±0.01 (X.XX±0.25)
2. Pin pitch tolerance ±0.01(0.25)
3. Pin dimension tolerance ±0.004 (0.1)

Pin Connection

PIN	DEFINE
1	+INPUT
2	-INPUT
3	CTRL
4	+OUTPUT
5	-OUTPUT
6	TRIM

EXTERNAL OUTPUT TRIMMING

Output can be externally trimmed by using the method shown below.

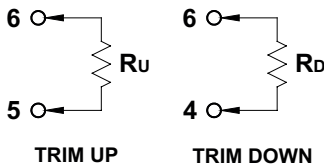

Recommended Pad Layout

Standard

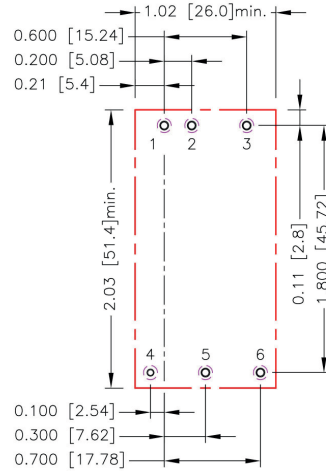

-HC

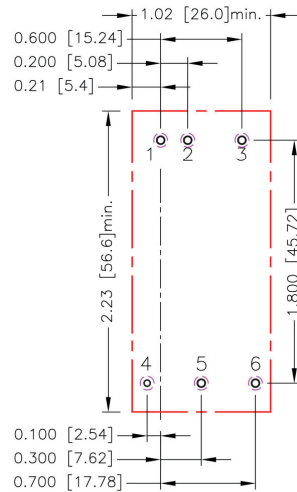

All dimensions in inch[mm]
 Pad size(lead free recommended)
 Through hole 1.2.3.4.5.6: ϕ 0.051[1.30]
 Top view pad 1.2.3.4.5.6: ϕ 0.064[1.63]
 Bottom view pad 1.2.3.4.5.6: ϕ 0.102[2.60]

Soldering Considerations

Lead free wave solder profile for PED40W series.

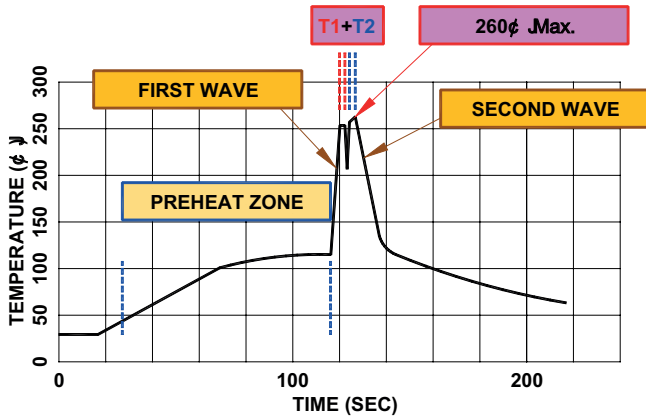

Zone	Reference Parameter
PREHEAT ZONE	Rise temp. speed : 3°C/ sec max. Preheat temp. : 100~130°C
ACTUAL HEATING	Peak temp. : 250~260°C Peak time (T1+T2 time) : 4~6 sec

Reference Solder: Sn-Ag-Cu; Sn-Cu
 Hand Welding: Soldering iron; Power 90W; Welding Time: 2-4 sec

Packing Information

Tube

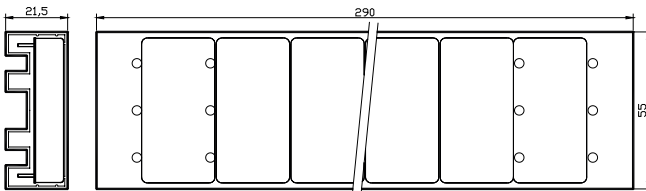

Box

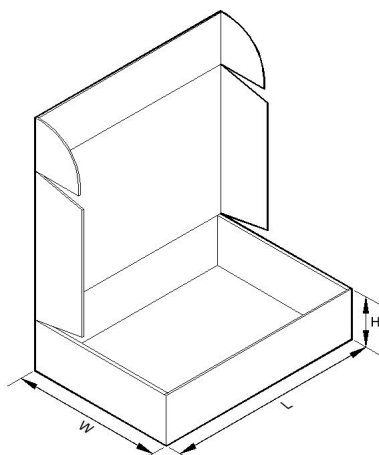

L x W x H = 335 x 235 x 9 mm
 3 trays in a box

Tray

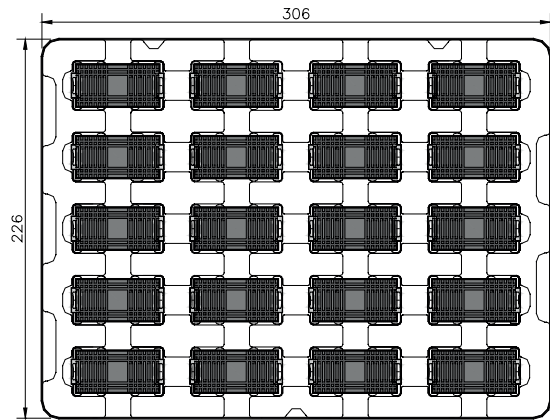

20pcs converters in a tray

Model Type	Packing Material	Quantity
Without Heat-sink	Tube	10 PCS / TUBE
With Heat-sink	Tray and Box	60 PCS / BOX

Safety and Installation Instruction

Fusing Consideration

Caution: This power module is not internally fused. An input line fuse must always be used. This encapsulated power module can be used in a wide variety of applications, ranging from simple stand-alone operation to an integrated part of sophisticated power architecture. To maximum flexibility, internal fusing is not included; however, to achieve maximum safety and system protection, always use an input line fuse. The safety agencies require a normal-blow fuse with maximum rating of 10 Based on the information provided in this data sheet on Inrush energy and maximum dc input current; the same type of fuse with lower rating can be used. Refer to the fuse manufacturer's data for further information.

MTBF and Reliability

The MTBF of PED40W SINGLE-SERIES of DC/DC converters has been calculated using MIL-HDBK 217F @Ta=25°C, FULL LOAD. The resulting figure for MTBF is 9.073×10⁵ hours.