

EVALUATION DATA

MODEL NAME : OFD1200A65-N

Tested by : *Shintaro Oki*
Shintaro Oki

Approved by : *Tomas Isaksson*
Tomas Isaksson

P R

B X



POWERBOX

A Cosel Group Company

Table of Contents

1. Input Current (by Load Current)	3
2. Efficiency (by Load Current).....	3
3. Power Factor (by Load Current)	4
4. Leakage Current	4
5. Inrush Current	5
6. Line Regulation.....	6
7. Load Regulation	6
8. Ripple Noise.....	7
9. Dynamic Load Response	7
10. Rise Time Characteristics by AC ON	8
11. Rise Time Characteristics with RC Signal.....	8
12. Fall Time / Hold-up Time	9
13. Over Current Protection	10
14. Minimum Input Voltage for Regulated Output Voltage	11
15. Over Voltage Protection	11
16. Conducted Emission	12
17. Figure of Test Circuitry	15

Remark:

Unless specified the test condition shall be

Input voltage / Frequency: 230 [Vac] / 50 [Hz]

Load current: 18.5 [A]

Baseplate temperature: 25 [°C]

1. Input Current (by Load Current)

Test Circuitry : Figure A

Graph

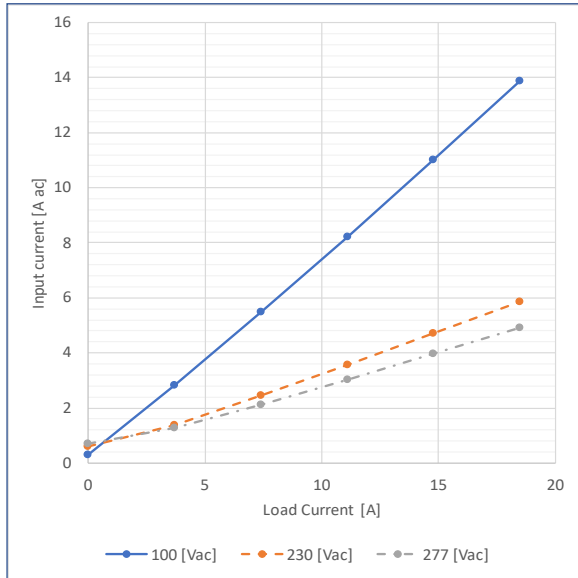

Value

Load Current [A]	Input Current [Aac]		
	Input Voltage		
	100 [Vac]	230 [Vac]	277 [Vac]
0.00	0.289	0.598	0.711
3.70	2.825	1.381	1.287
7.40	5.489	2.447	2.135
11.10	8.211	3.566	3.043
14.80	11.011	4.706	3.981
18.50	13.894	5.863	4.932

2. Efficiency (by Load Current)

Test Circuitry : Figure A

Graph

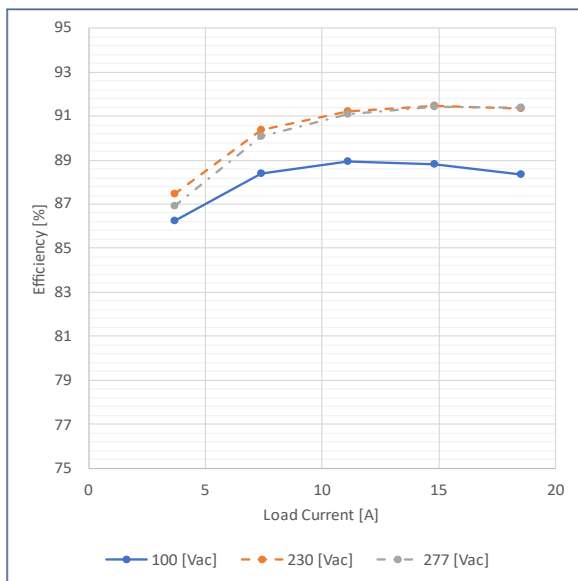

Value

Load Current [A]	Efficiency [%]		
	Input Voltage		
	100 [Vac]	230 [Vac]	277 [Vac]
0.00	-	-	-
3.70	86.221	87.472	86.897
7.40	88.396	90.350	90.077
11.10	88.923	91.230	91.065
14.80	88.816	91.476	91.412
18.50	88.338	91.342	91.374

3. Power Factor (by Load Current)

Test Circuitry : Figure A

Graph

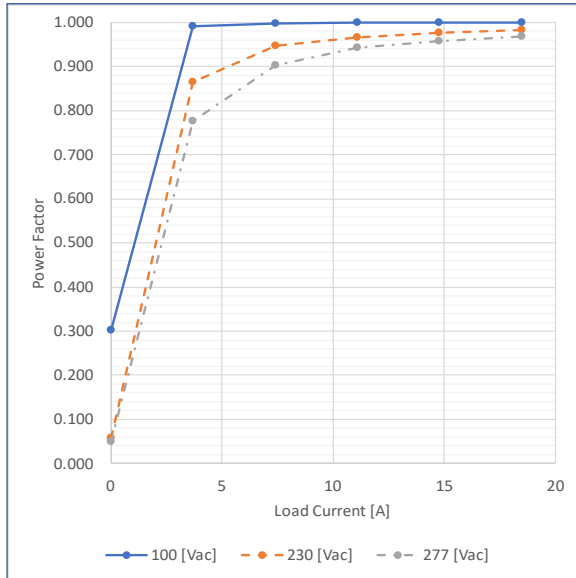

Value

Load Current [A]	Power Factor		
	Input Voltage		
	100 [Vac]	230 [Vac]	277 [Vac]
0.00	0.303	0.058	0.050
3.70	0.991	0.866	0.777
7.40	0.998	0.947	0.904
11.10	0.999	0.967	0.942
14.80	0.999	0.976	0.958
18.50	0.999	0.982	0.968

4. Leakage Current

Test Circuitry : See table

Test Equipment: Simpson 228

Value

Standard	Testing Circuitry	Measuring Method	Leakage Current [mA]			Note
			Input Voltage			
			100 [Vac]	230 [Vac]	277 [Vac]	
IEC62368-1	Figure B-1	Both phases	0.25	0.60	0.74	Operation
		One of phases	0.44	1.20	1.45	Stand by
	Figure B-2	Both phases	0.25	0.60	0.74	Operation
		One of phases	0.44	1.20	1.45	Stand by

5. Inrush Current

Test Circuitry : Figure A

— C1: Input Voltage (200V/div)
 — C2: Input Current (25A/div)

Waveform

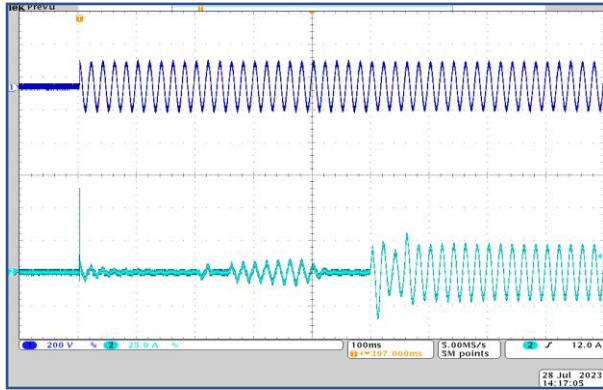

Input Voltage : 100 [Vac]
 (100ms/div)

- ① Primary Inrush Current : 14.0 [A]
- ② Secondary Inrush Current : 33.5 [A]

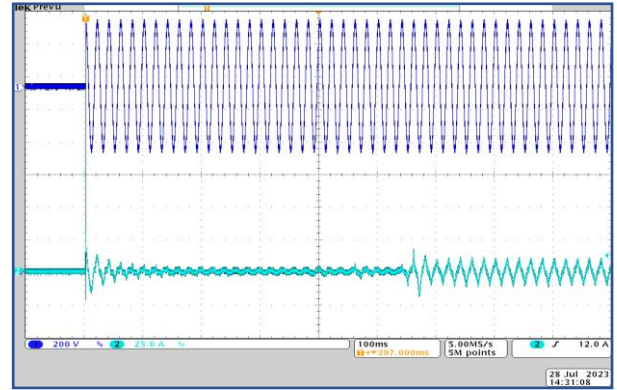

Input Voltage : 277 [Vac]
 (100ms/div)

- ① Primary Inrush Current : 27.0 [A]
- ② Secondary Inrush Current : 15.5 [A]

Remark:

A surge current flown into Line-to-Line capacitor (③) would be excluded as primary inrush current (①).

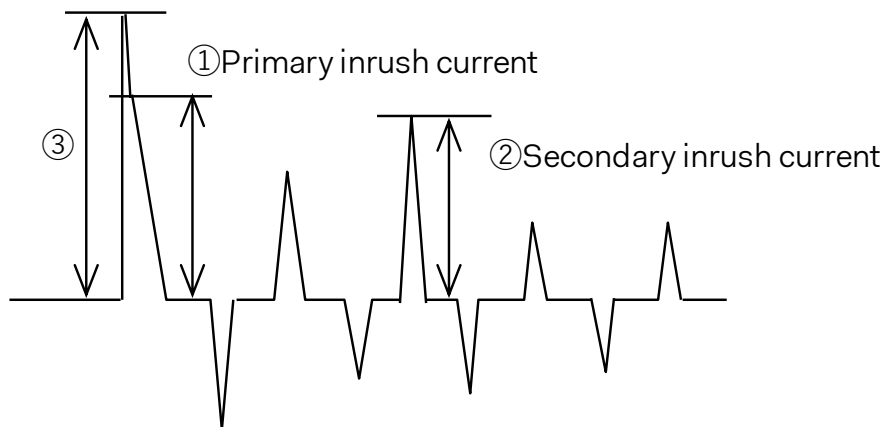

6. Line Regulation

Test Circuitry : Figure A

Change input voltage from 85 to 277 [Vac]

Graph

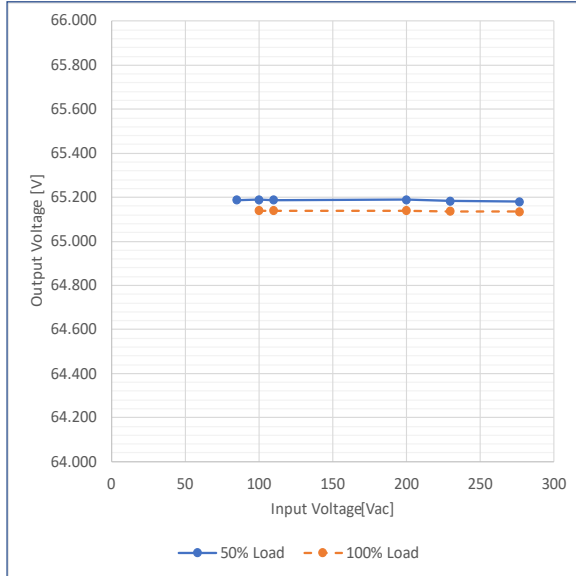

Value

Input Voltage [Vac]	Output Voltage [V]	
	Load Factor	
	50% Load	100% Load
85.00	65.188	-
100.00	65.189	65.139
110.00	65.188	65.139
200.00	65.189	65.140
230.00	65.183	65.136
277.00	65.180	65.135

7. Load Regulation

Test Circuitry : Figure A

Change Load Current from 0 to 25.0 [A]

Graph

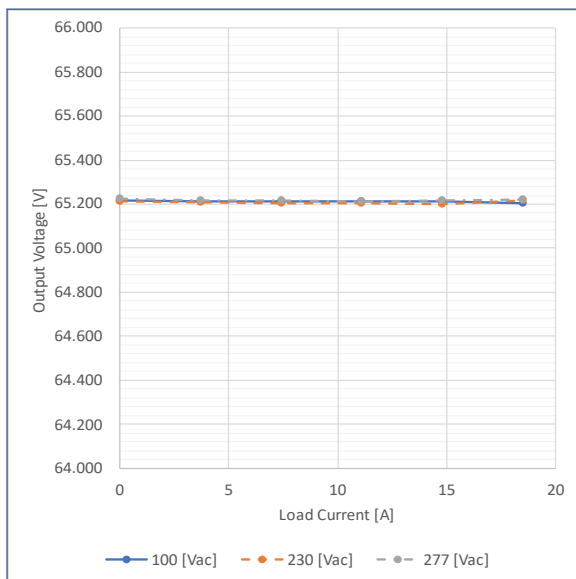

Value

Load Current [A]	Output Voltage [V]		
	Input Voltage		
	100 [Vac]	230 [Vac]	277 [Vac]
0.00	65.215	65.213	65.224
3.70	65.214	65.207	65.217
7.40	65.214	65.205	65.215
11.10	65.213	65.205	65.214
14.80	65.211	65.201	65.215
18.50	65.204	65.215	65.219

8. Ripple Noise

Test Circuitry : Figure C

— C4: Output voltage
 BW: 20MHz

Waveform

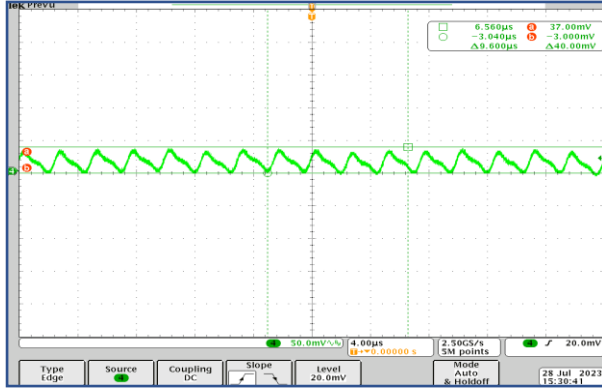

(4µs/div)
 (50mV/div)

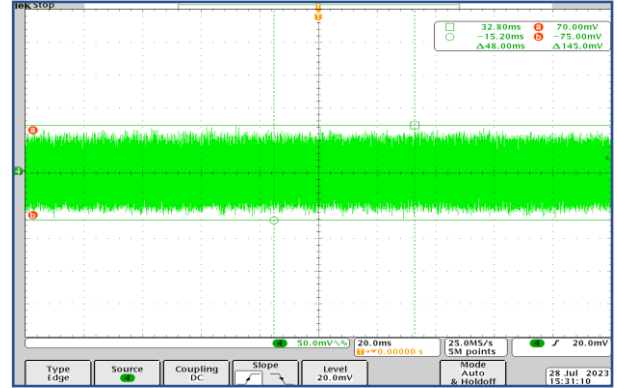

(20ms/div)
 (50mV/div)

9. Dynamic Load Response

Test Circuitry: Figure A
 Load Current: 1.85 [A] <-> 16.65 [A]

— C2: Output voltage (2V/div)
— C4: Output current (10A/div)

Waveform

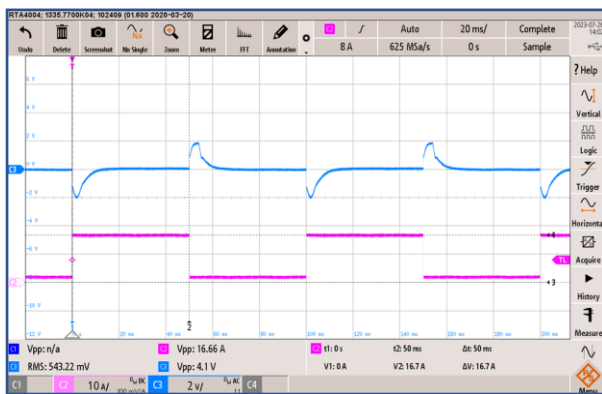

(20ms/div)

Load changes from 10% to 90% of rated current.

10. Rise Time Characteristics by AC ON

Test Circuitry : Figure A

— C1: Input voltage
— C3: Output voltage (20V/div)

Waveform

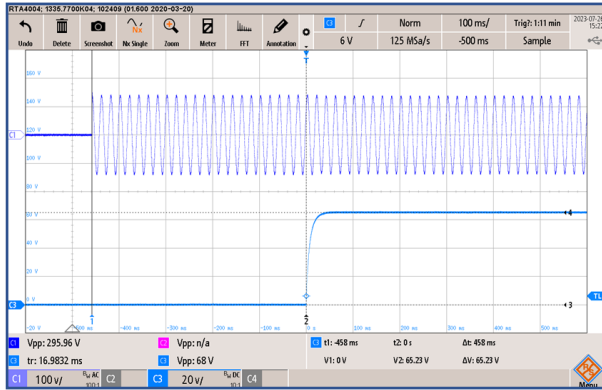

Input Voltage 100 [Vac]
Load Current 18.5 [A]
(100ms/div)

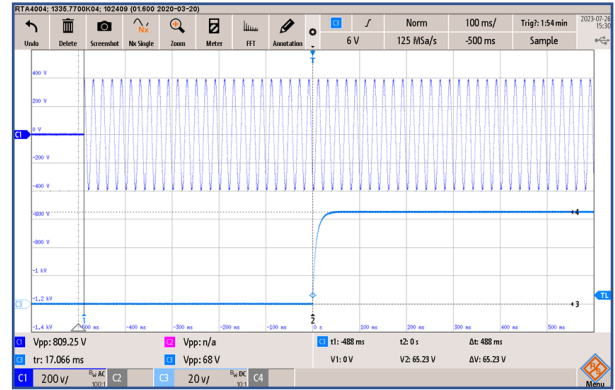

Input Voltage 277 [Vac]
Load Current 18.5 [A]
(100ms/div)

11. Rise Time Characteristics with RC Signal

Test Circuitry : Figure D

— C1: Input voltage (500V/div)
— C3: RC signal (10V/div)
— C4: Output voltage (20V/div)

Waveform

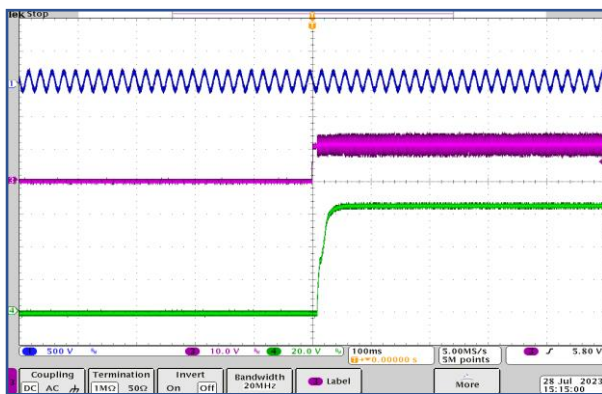

Input Voltage 100 [Vac]
Load Current 18.5 [A]
(100ms/div)

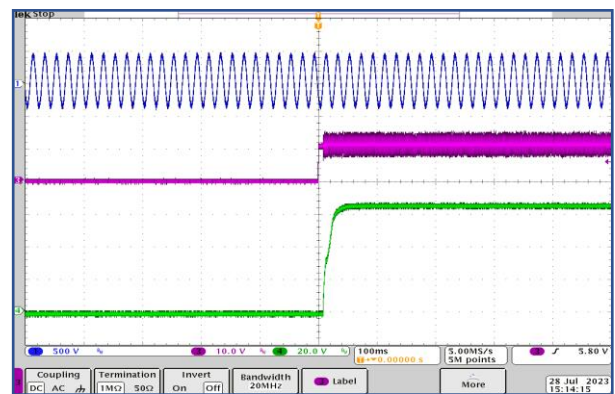

Input Voltage 277 [Vac]
Load Current 18.5 [A]
(100ms/div)

12. Fall Time / Hold-up Time

Test Circuitry : Figure A

— C1: Input voltage (200V/div)
 — C2: Output voltage (20V/div)

Waveform

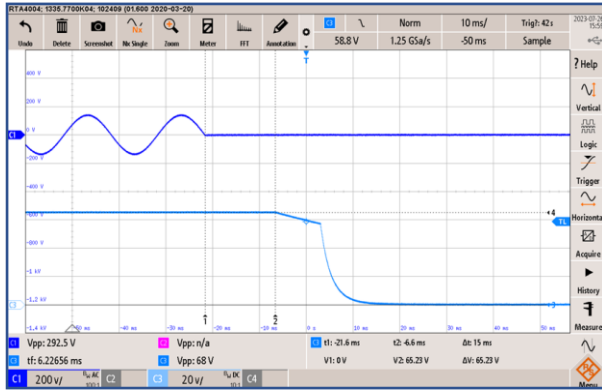

Input Voltage 100 [Vac]
 Load Current 18.5 [A]
 (10ms/div)

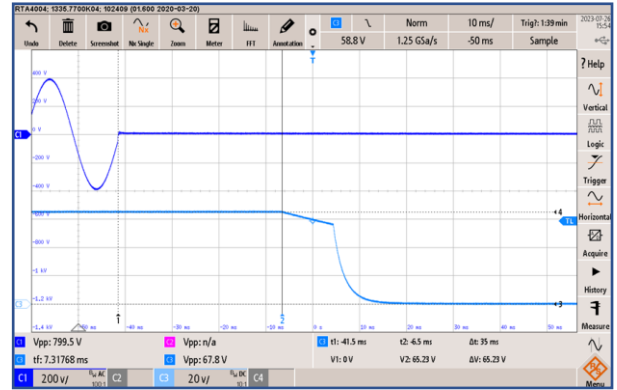

Input Voltage 277 [Vac]
 Load Current 18.5 [A]
 (10ms/div)

Graph

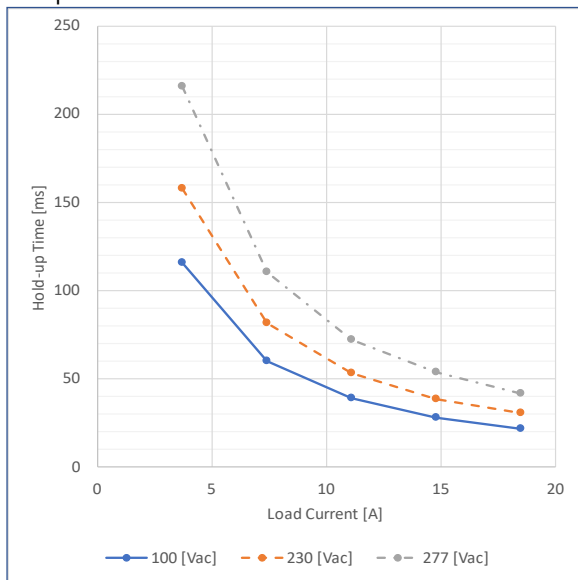

Value

Load Current [A]	Hold-up Time [ms]		
	Input Voltage		
	100 [Vac]	230 [Vac]	277 [Vac]
0.00	-	-	-
3.70	115.5	158.0	215.5
7.40	59.8	81.4	110.5
11.10	38.8	53.2	72.0
14.80	28.0	38.6	53.4
18.50	21.6	30.4	41.6

13. Over Current Protection

Test Circuitry : Figure A

Graph

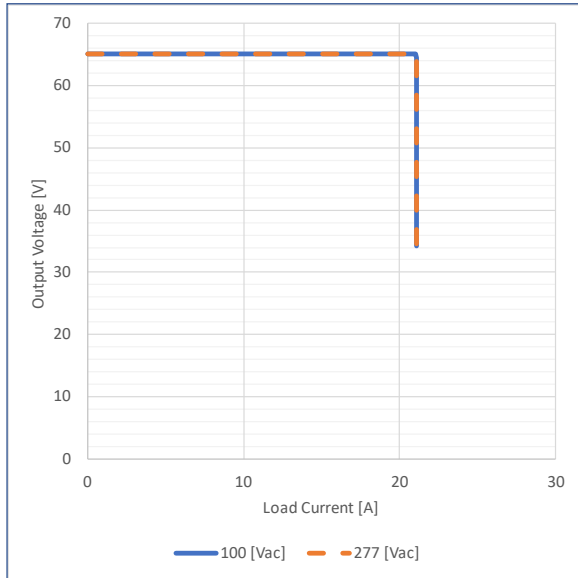

Value

Output Voltage [V]	Load Current [A]	
	Input Voltage	
	100 [Vac]	277 [Vac]
65.00	21.030	21.039
61.75	21.061	21.072
58.50	21.061	21.070
52.00	21.061	21.071
45.50	21.061	21.069
39.00	21.062	21.069
32.50	21.057	21.066

Waveform

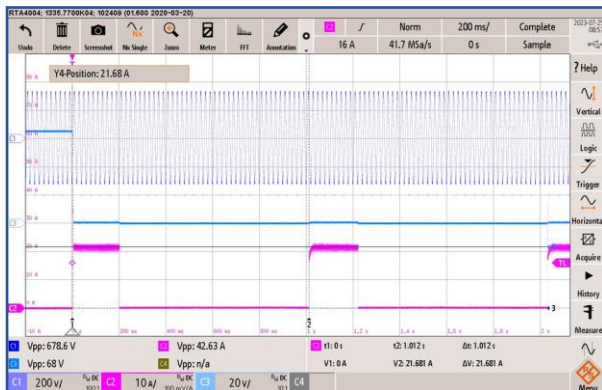

Input Voltage 230 [Vac]
 Output Short
 (200ms/div)

- C1: Input voltage (200V/div)
- C2: Output Current (10A/div)
- C3: Output voltage (20V/div)

Intermittent operation occurs when the output voltage is from 30.0V to 0V.

14. Minimum Input Voltage for Regulated Output Voltage

Test Circuitry : Figure A

Graph

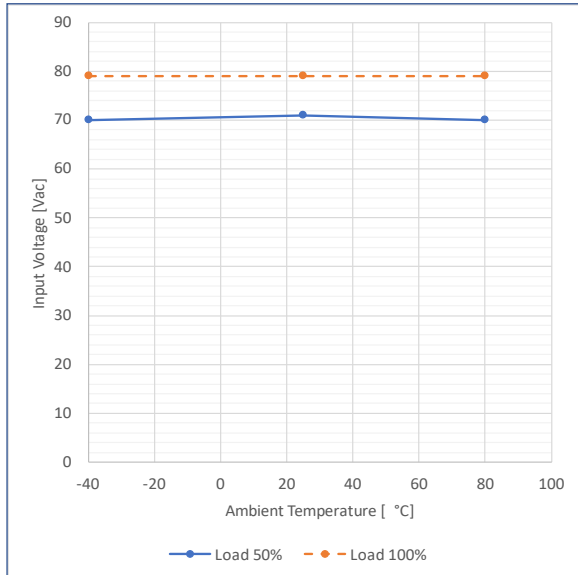

Value

Baseplate Temperature [°C]	Input Voltage [Vac]	
	Load Current	
	Load 50%	Load 100%
-40	70	79
25	71	79
80	70	79

15. Over Voltage Protection

Test Circuitry : Figure A

Graph

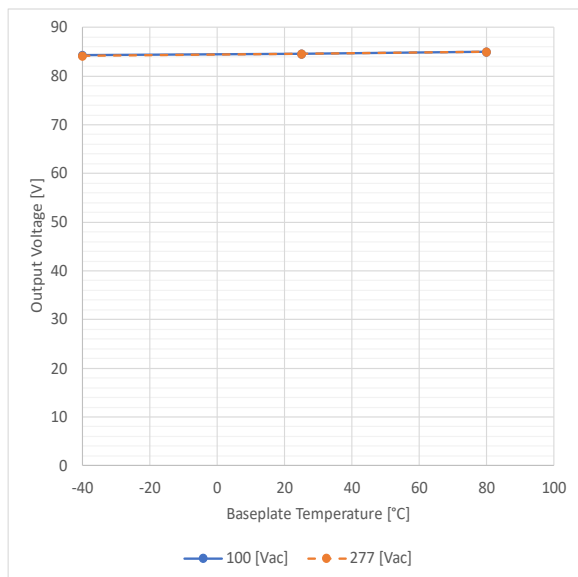

Value

Baseplate Temperature [°C]	Output Voltage [V]	
	Input Voltage	
	100 [Vac]	277 [Vac]
-40	84.290	84.170
25	84.580	84.580
80	84.990	84.990

16. Conducted Emission

Input Voltage : 115Vac / 230Vac 50Hz Load : 100 %

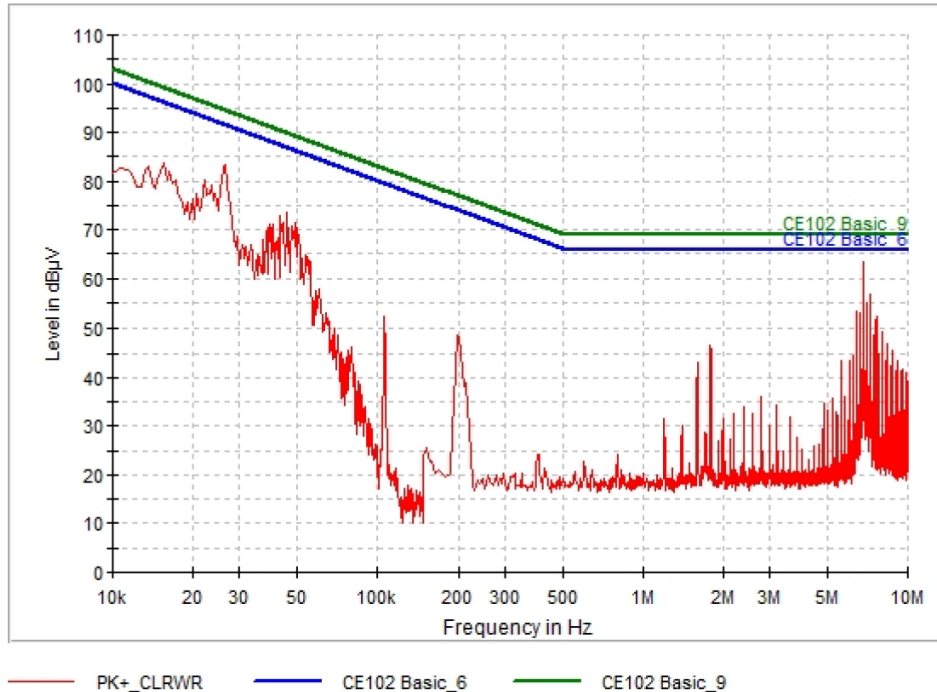

Fig. 16.1 MIL-STD-461F CE102 Result OFD1200A65, 115V, N

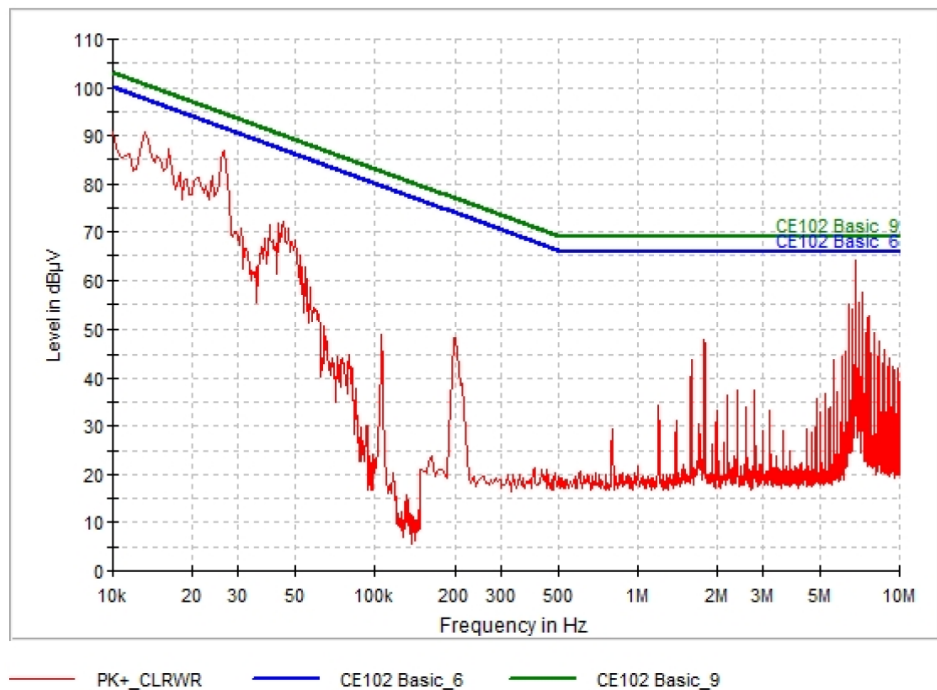
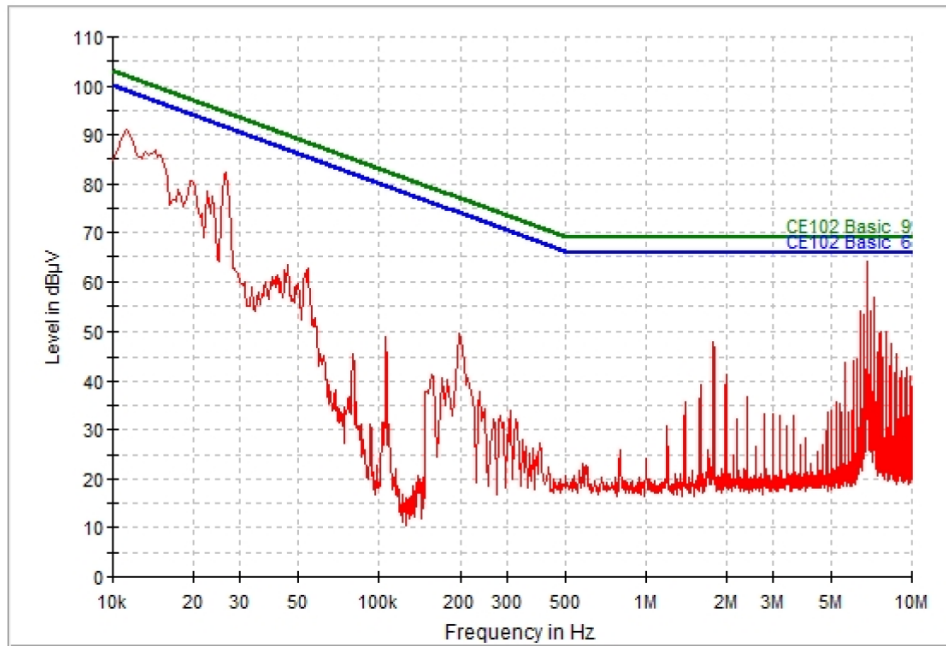
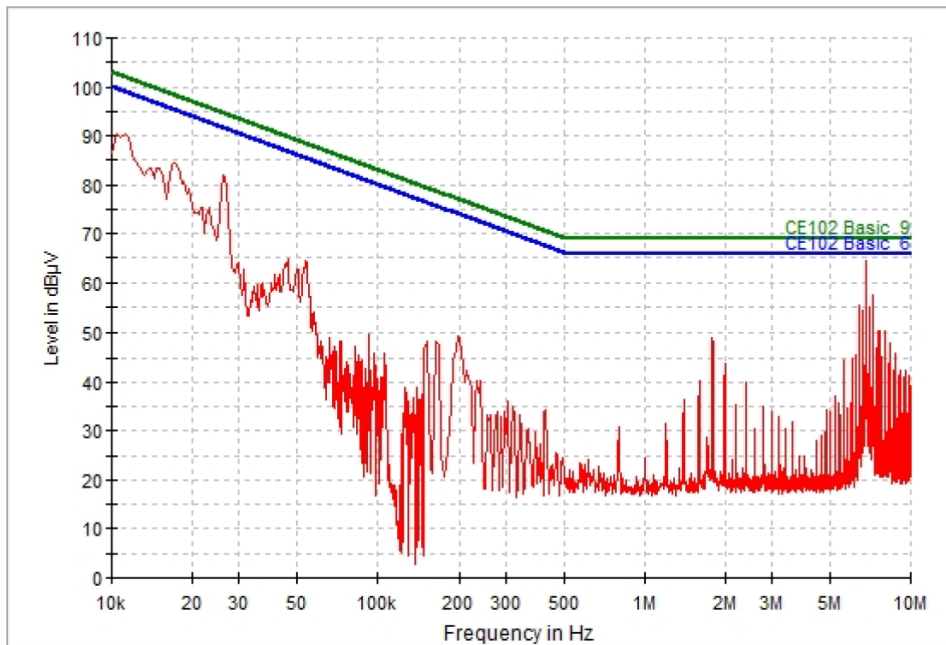

Fig. 16.2 MIL-STD-461F CE102 Result OFD1200A65, 115V, L1



— PK+_CLRWR — CE102 Basic_6 — CE102 Basic_9

Fig. 16.3 MIL-STD-461F CE102 Result OFD1200A65, 230V, N



— PK+_CLRWR — CE102 Basic_6 — CE102 Basic_9

Fig. 16.4 MIL-STD-461F CE102 Result OFD1200A65, 230V, L1

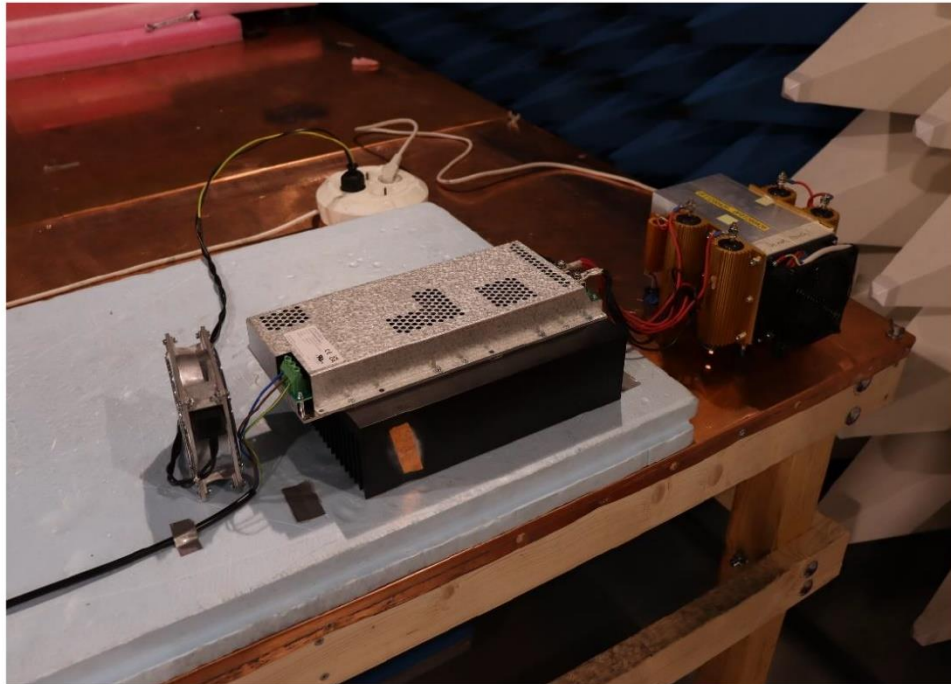

Fig. 16.5 MIL-STD-461F CE102 test environment

17. Figure of Test Circuitry

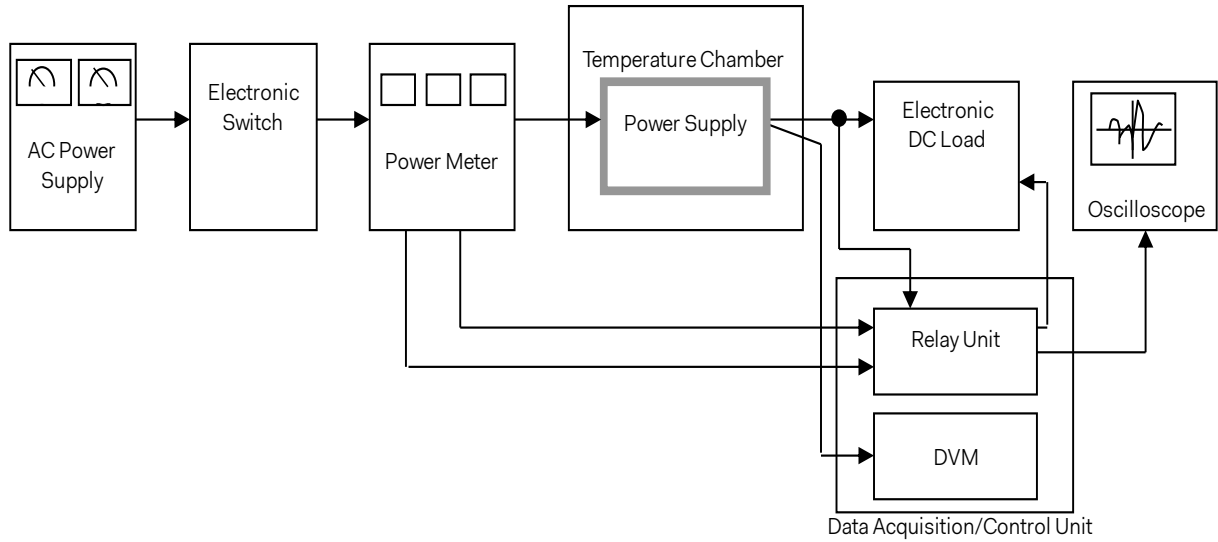

Figure A Test circuitry for general performance measurement

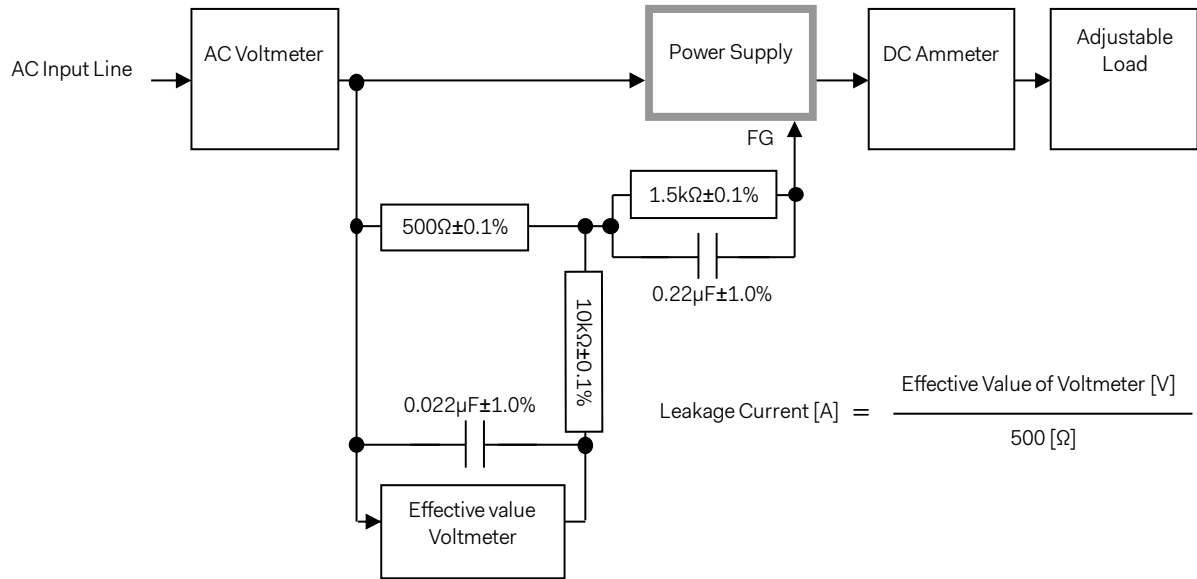

Figure B-1 Leakage current measurement (IEC62368-1, refer to IEC60990 Fig.4)

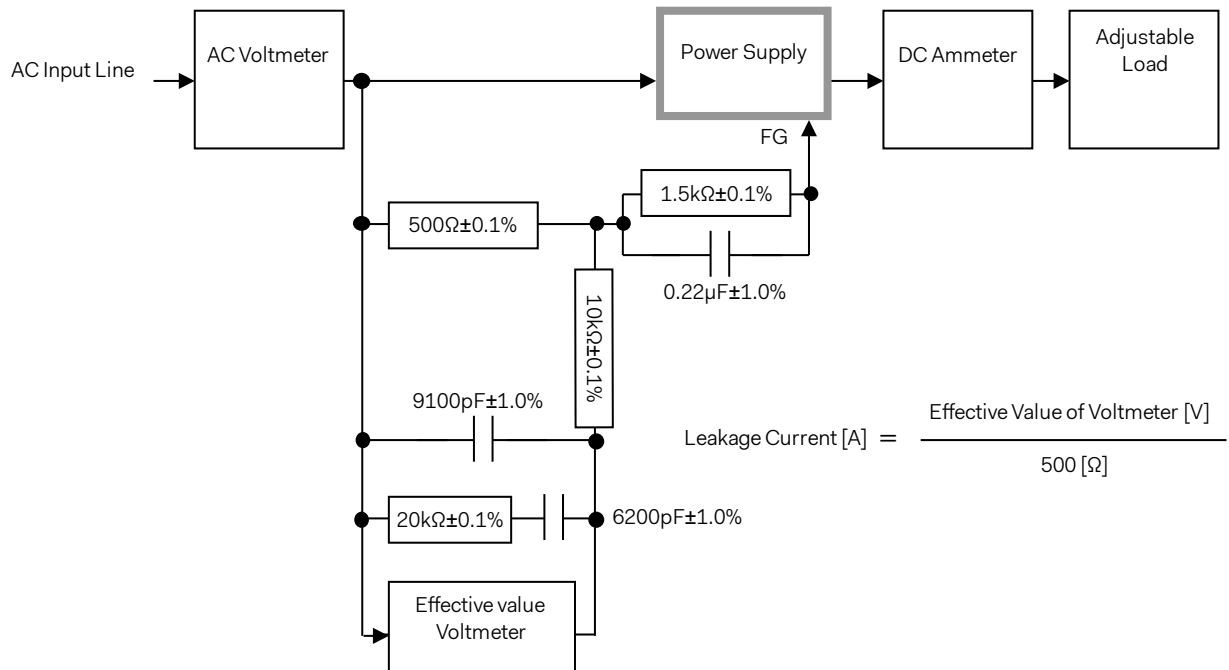

Figure B-2 Leakage current measurement (IEC62368-1, refer to IEC60990 Fig.5)

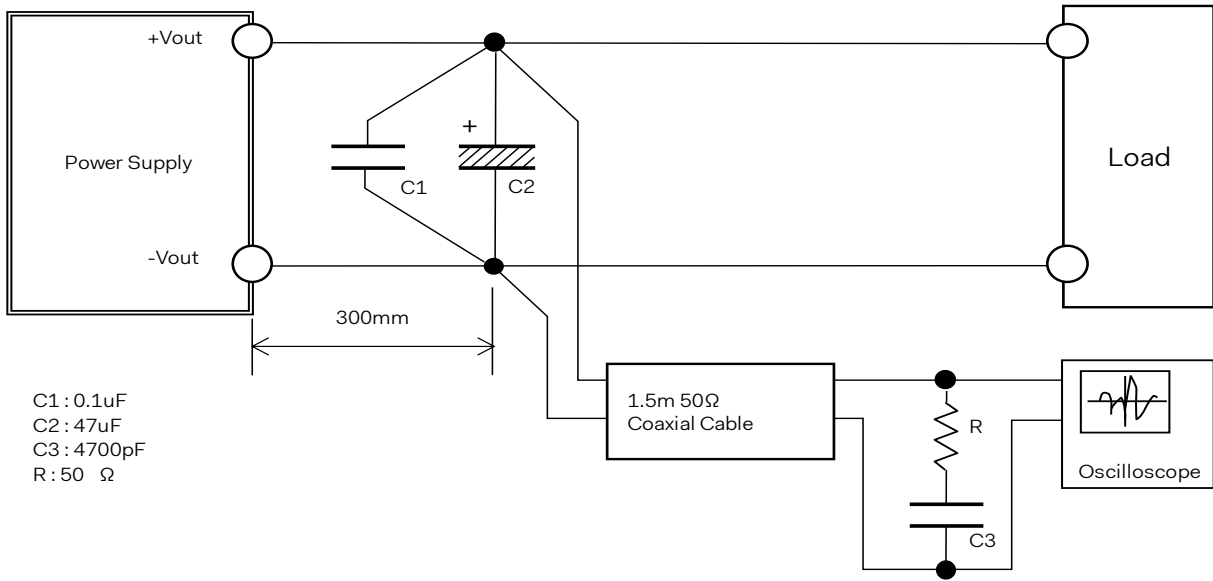

Figure C Ripple voltage measurement (JEITA RC-9131D)

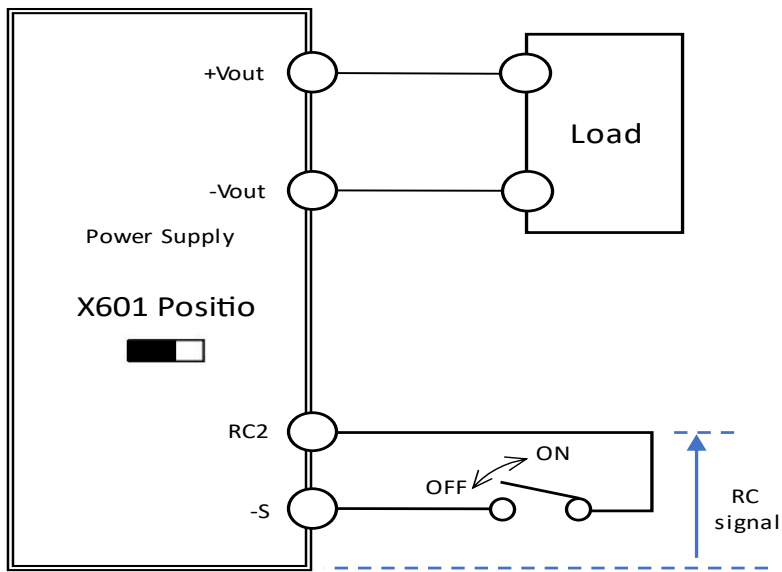

Figure D Turn on by RC measurement