

EVALUATION DATA

MODEL NAME : OFD1200A28-N

Tested by : *Shintaro Oki*
Shintaro Oki

Approved by : *Tomas Isaksson*
Tomas Isaksson

P R

B X

POWERBOX
A Cosel Group Company

Table of Contents

1. Input Current (by Load Current)	3
2. Efficiency (by Load Current).....	3
3. Power Factor (by Load Current)	4
4. Leakage Current	4
5. Inrush Current	5
6. Line Regulation	6
7. Load Regulation	6
8. Ripple Noise.....	7
9. Dynamic Load Response	7
10. Rise Time Characteristics by AC ON	8
11. Rise Time Characteristics with RC Signal.....	8
12. Fall Time / Hold-up Time	9
13. Over Current Protection	10
14. Minimum Input Voltage for Regulated Output Voltage	11
15. Over Voltage Protection	11
16. Conducted Emission	12
17. Figure of Test Circuitry	15

Remark:

Unless specified the test condition shall be

Input voltage / Frequency: 230 [Vac] / 50 [Hz]

Load current: 43.0 [A]

Baseplate temperature: 25 [°C]

1. Input Current (by Load Current)

Test Circuitry : Figure A

Graph

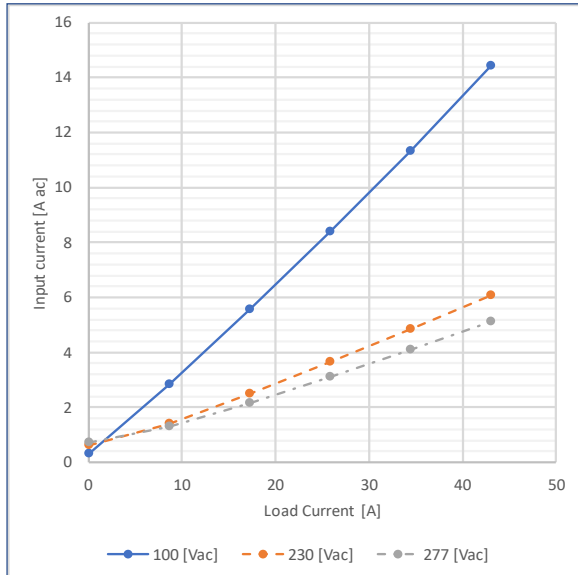

Value

Load Current [A]	Input Current [Aac]		
	Input Voltage		
	100 [Vac]	230 [Vac]	277 [Vac]
0.00	0.303	0.618	0.722
8.60	2.838	1.389	1.294
17.20	5.559	2.477	2.158
25.80	8.377	3.634	3.101
34.40	11.326	4.834	4.085
43.00	14.432	6.073	5.100

2. Efficiency (by Load Current)

Test Circuitry : Figure A

Graph

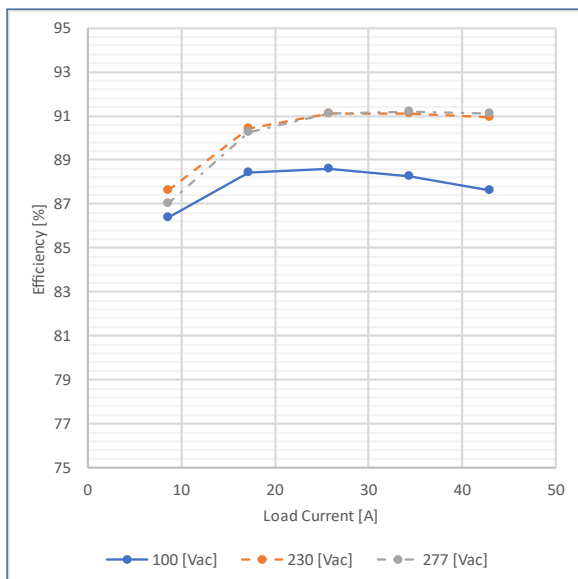

Value

Load Current [A]	Efficiency [%]		
	Input Voltage		
	100 [Vac]	230 [Vac]	277 [Vac]
0.00	-	-	-
8.60	86.387	87.615	87.034
17.20	88.403	90.424	90.245
25.80	88.604	91.095	91.113
34.40	88.250	91.097	91.205
43.00	87.593	90.924	91.101

3. Power Factor (by Load Current)

Test Circuitry : Figure A

Graph

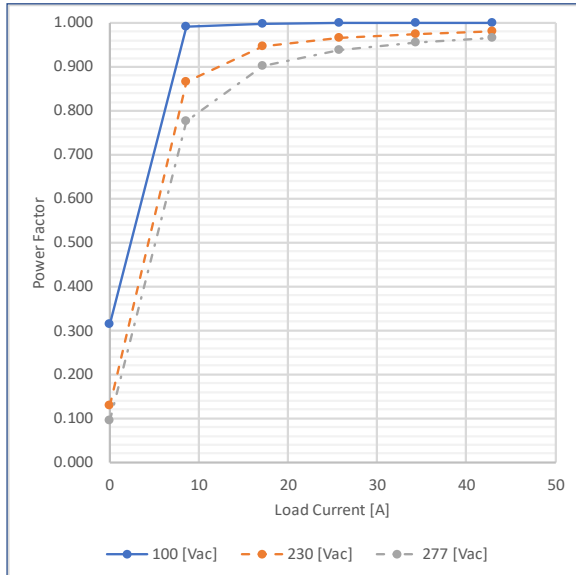

Value

Load Current [A]	Power Factor		
	Input Voltage		
	100 [Vac]	230 [Vac]	277 [Vac]
0.00	0.315	0.129	0.095
8.60	0.991	0.866	0.777
17.20	0.997	0.946	0.903
25.80	0.999	0.966	0.939
34.40	0.999	0.975	0.956
43.00	0.999	0.980	0.966

4. Leakage Current

Test Circuitry : See table

Test Equipment: Simpson 228

Value

Standard	Testing Circuitry	Measuring Method	Leakage Current [mA]			Note
			Input Voltage			
			100 [Vac]	230 [Vac]	277 [Vac]	
IEC62368-1	Figure B-1	Both phases	0.25	0.60	0.74	Operation
		One of phases	0.44	1.20	1.45	Stand by
	Figure B-2	Both phases	0.25	0.60	0.74	Operation
		One of phases	0.44	1.20	1.45	Stand by

5. Inrush Current

Test Circuitry : Figure A

— C1: Input Voltage (200V/div)
— C4: Input Current (20A/div)

Waveform

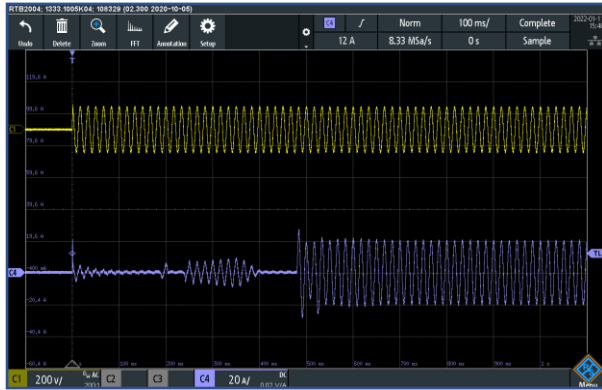

Input Voltage : 100 [Vac]
(100ms/div)

- ① Primary Inrush Current : 12.7 [A]
- ② Secondary Inrush Current : 27.9 [A]

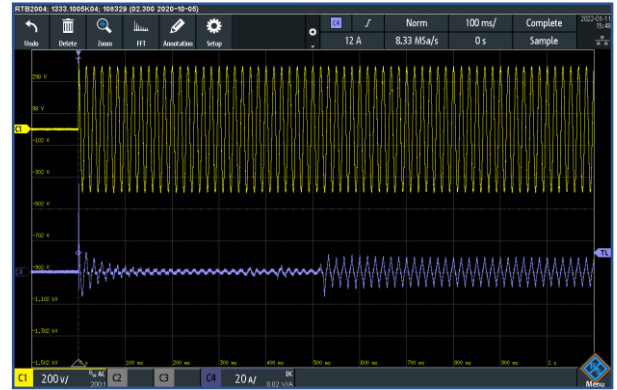

Input Voltage : 277 [Vac]
(100ms/div)

- ① Primary Inrush Current : 36.3 [A]
- ② Secondary Inrush Current : 15.6 [A]

Remark:

A surge current flown into Line-to-Line capacitor (③) would be excluded as primary inrush current (①).

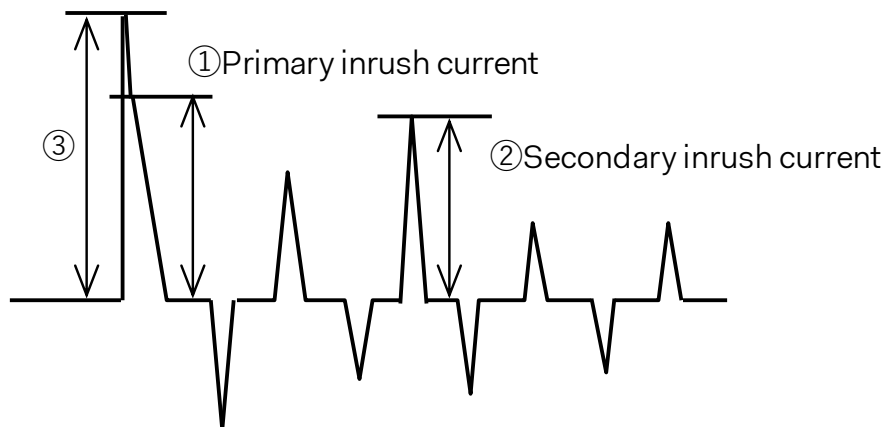

6. Line Regulation

Test Circuitry : Figure A

Change input voltage from 85 to 277 [Vac]

Graph

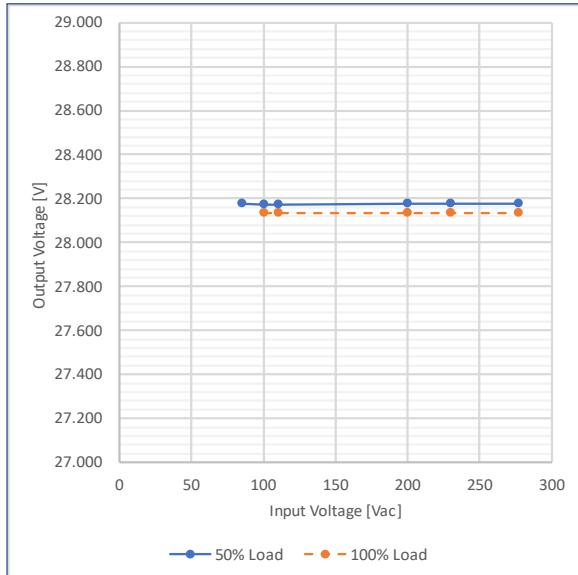

Value

Input Voltage [Vac]	Output Voltage [V]	
	Load Factor	
	50% Load	100% Load
85.00	28.175	-
100.00	28.174	28.132
110.00	28.174	28.132
200.00	28.175	28.132
230.00	28.175	28.132
277.00	28.175	28.132

7. Load Regulation

Test Circuitry : Figure A

Change Load Current from 0 to 43.0 [A]

Graph

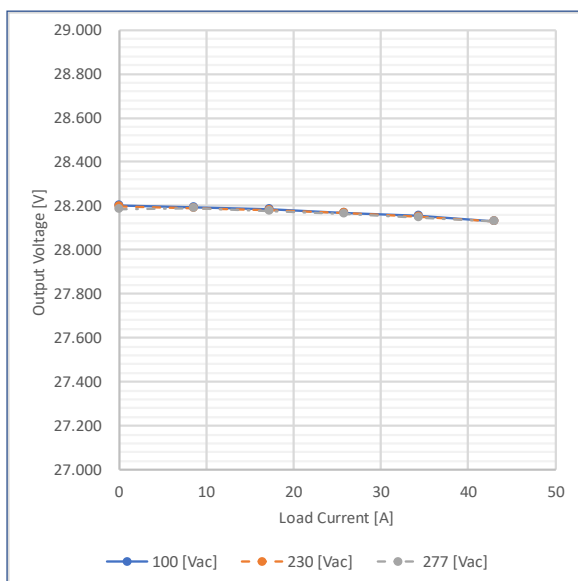

Value

Load Current [A]	Output Voltage [V]		
	Input Voltage		
	100 [Vac]	230 [Vac]	277 [Vac]
0.00	28.200	28.196	28.184
8.60	28.192	28.189	28.187
17.20	28.186	28.182	28.178
25.80	28.167	28.166	28.164
34.40	28.153	28.149	28.147
43.00	28.128	28.129	28.129

8. Ripple Noise

Test Circuitry : Figure C

— C2: Output voltage (20mV/div)
 BW: 20MHz

Waveform



(5μs/div)



(200ms/div)

9. Dynamic Load Response

Test Circuitry : Figure A
 Load Current 4.3 [A] <-> 38.7 [A]

— C2: Output voltage (50mV/div)
— C4: Output current (20A/div)

Waveform



(20ms/div)

Load changes from 10% to 90% of rated current.

10. Rise Time Characteristics by AC ON

Test Circuitry : Figure A

— C1: Input voltage (200V/div)
— C2: Output voltage (10V/div)

Waveform

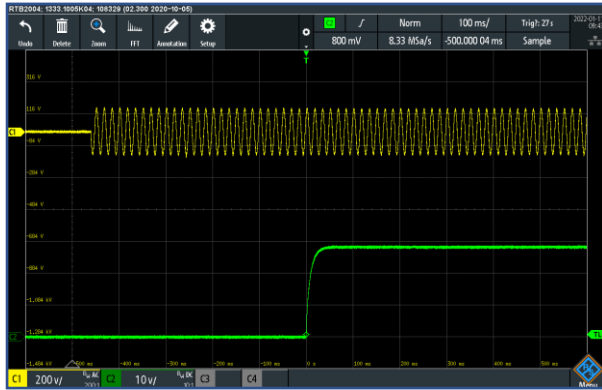

Input Voltage 100 [Vac]
 Load Current 43.0 [A]
 (100ms/div)

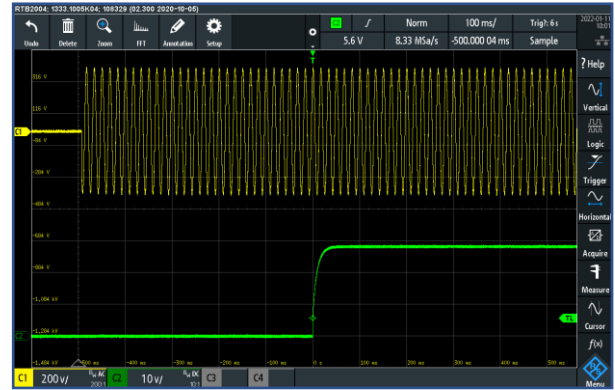

Input Voltage 277 [Vac]
 Load Current 43.0 [A]
 (100ms/div)

11. Rise Time Characteristics with RC Signal

Test Circuitry : Figure D

— C1: Input voltage (500V/div)
— C2: Output voltage (10V/div)
— C3: RC signal (10V/div)

Waveform



Input Voltage 100 [Vac]
 Load Current 43.0 [A]
 (100ms/div)

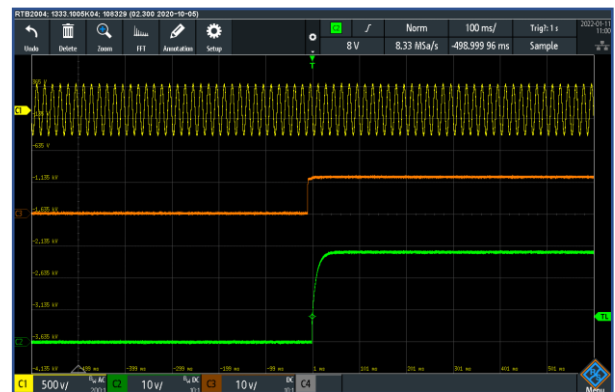

Input Voltage 277 [Vac]
 Load Current 43.0 [A]
 (100ms/div)

12. Fall Time / Hold-up Time

Test Circuitry : Figure A

— C1: Input voltage (200V/div)
— C2: Output voltage (10V/div)

Waveform



Input Voltage 100 [Vac]
Load Current 43.0 [A]
(10ms/div)



Input Voltage 277 [Vac]
Load Current 43.0 [A]
(10ms/div)

Graph

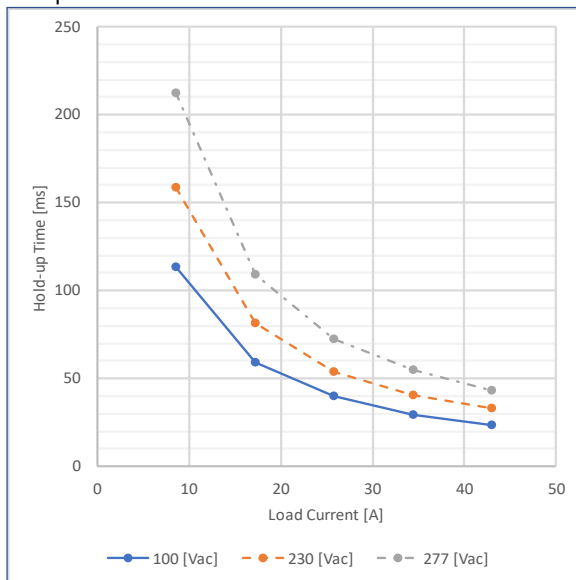

Value

Load Current [A]	Hold-up Time [ms]		
	Input Voltage		
	100 [Vac]	230 [Vac]	277 [Vac]
0.00	-	-	-
8.60	113.5	158.5	212.5
17.20	59.2	81.4	109.0
25.80	40.2	54.0	72.4
34.40	29.2	40.6	54.6
43.00	23.7	32.9	43.2

13. Over Current Protection

Test Circuitry : Figure A

Graph

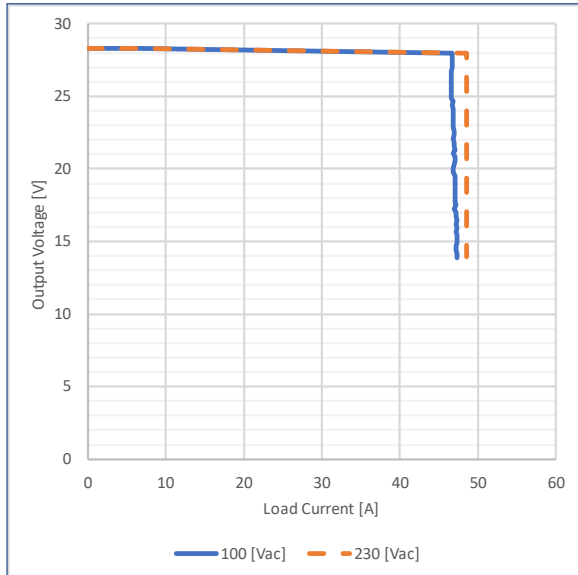

Value

Output Voltage [V]	Load Current [A]	
	Input Voltage	
	100 [Vac]	230 [Vac]
28.00	46.688	48.538
26.60	46.578	48.537
25.20	46.582	48.537
22.40	46.913	48.549
19.60	46.871	48.566
16.80	47.163	48.576

Waveform

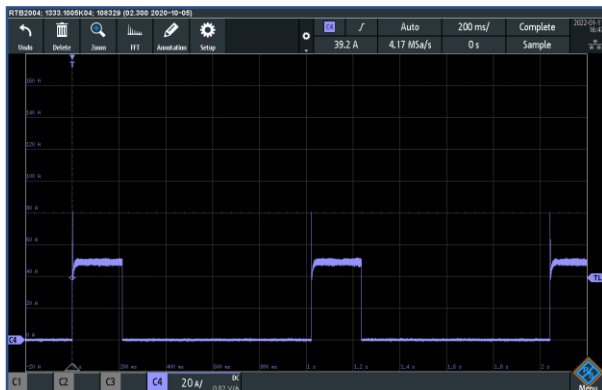

C4: Output Current (20A/div)

Intermittent operation occurs when the output voltage is from 14.0V to 0V.

Input Voltage 230 [Vac]
 Output Short
 (200ms/div)

14. Minimum Input Voltage for Regulated Output Voltage

Test Circuitry : Figure A

Graph

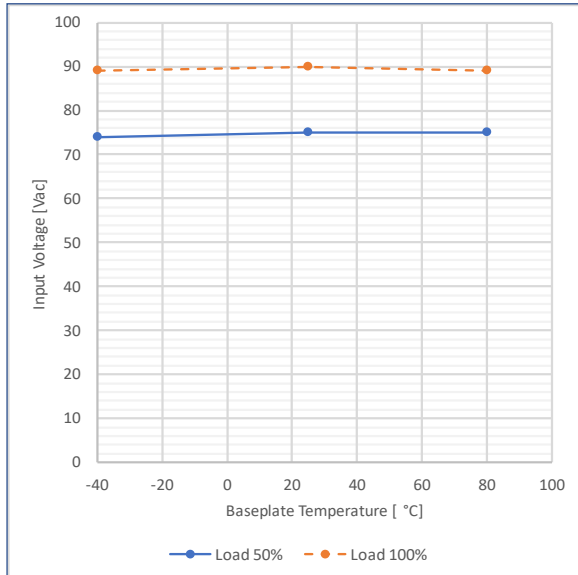

Value

Baseplate Temperature [°C]	Input Voltage [Vac]	
	Load Current	
	Load 50%	Load 100%
-40	74	89
25	75	90
80	75	89

The low input voltage protection is activated on the condition of load 100%.

15. Over Voltage Protection

Test Circuitry : Figure A

Graph

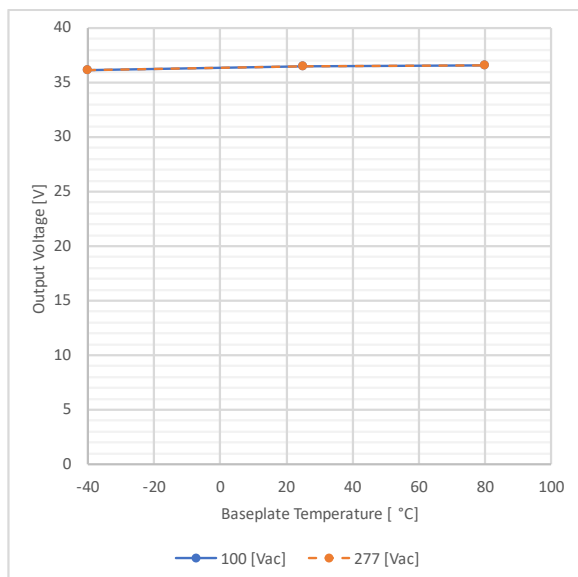

Value

Baseplate Temperature [°C]	Output Voltage [V]	
	Input Voltage	
	100 [Vac]	277 [Vac]
-40	36.160	36.160
25	36.450	36.460
80	36.570	36.570

16. Conducted Emission

Input Voltage : 115Vac / 230Vac 50Hz Load : 100 %

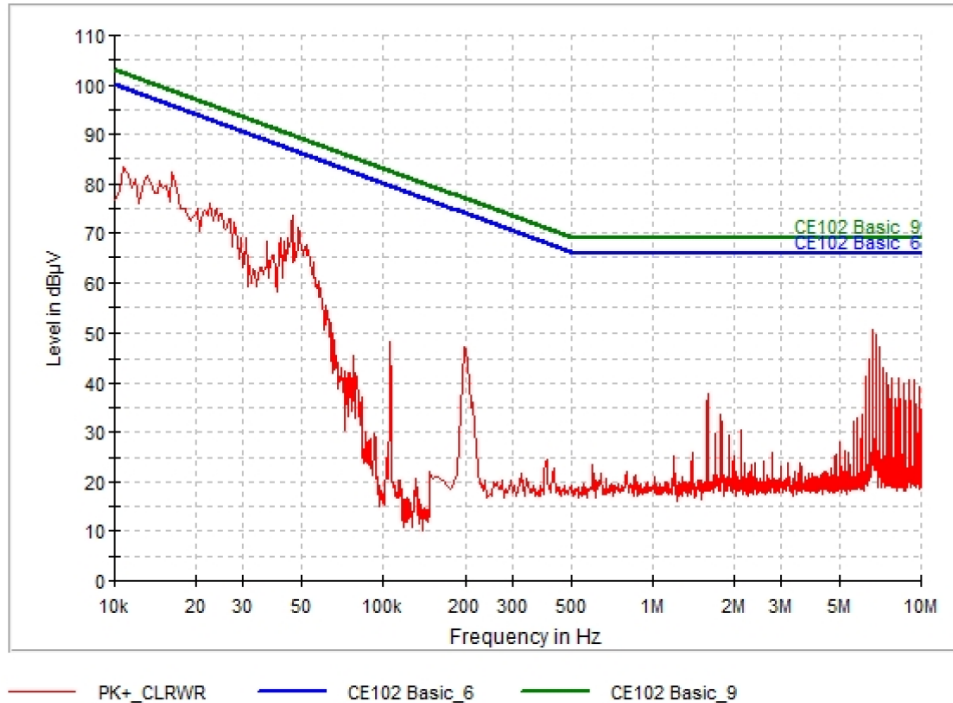

Fig. 16.1 MIL-STD-461F CE102 Result OFD1200A28, 115V, N

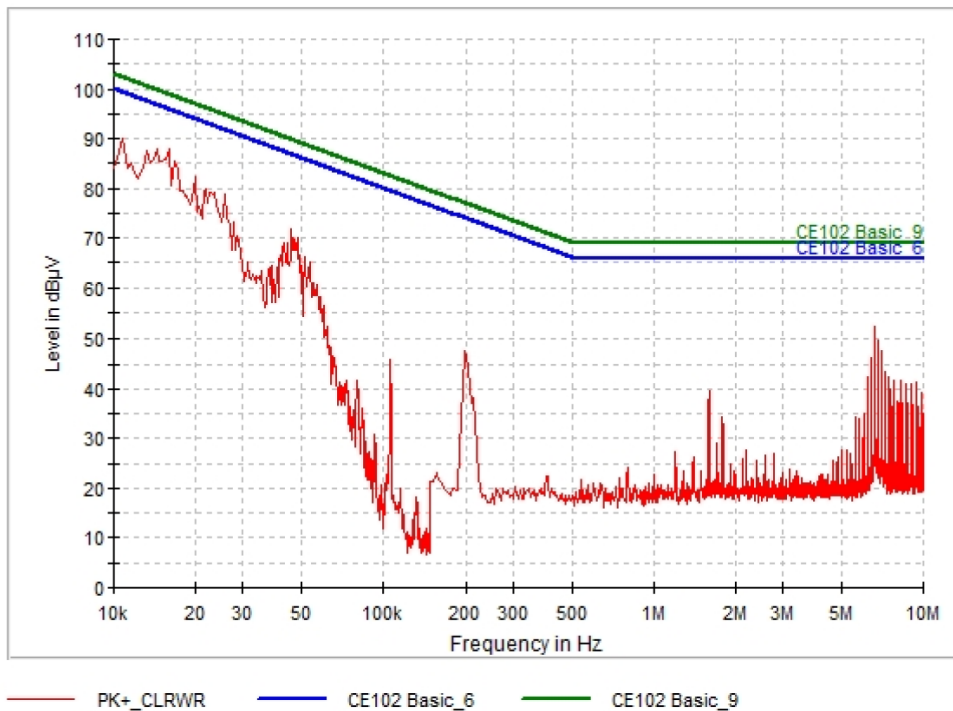
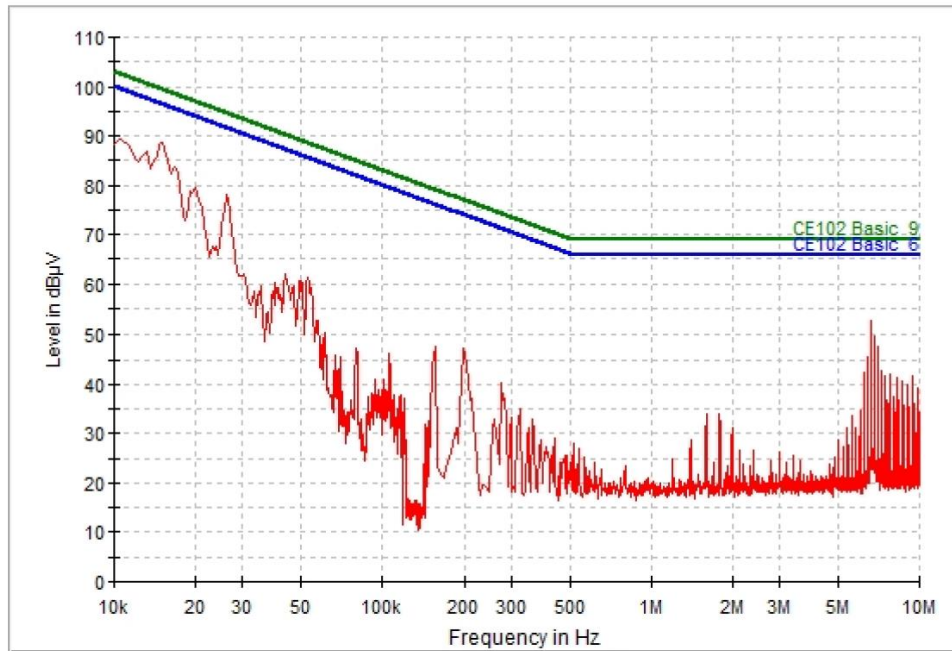
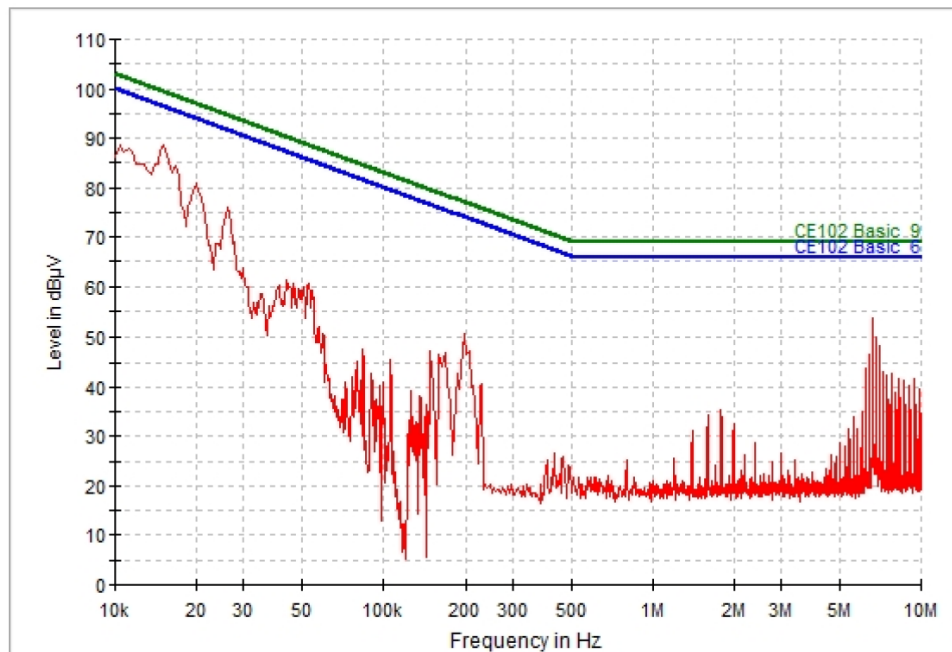

Fig. 16.2 MIL-STD-461F CE102 Result OFD1200A28, 115V, L1



— PK+_CLRWR
 — CE102 Basic_6
 — CE102 Basic_9

Fig. 16.3 MIL-STD-461F CE102 Result OFD1200A28, 230V, N



— PK+_CLRWR
 — CE102 Basic_6
 — CE102 Basic_9

Fig. 16.4 MIL-STD-461F CE102 Result OFD1200A28, 230V, L1

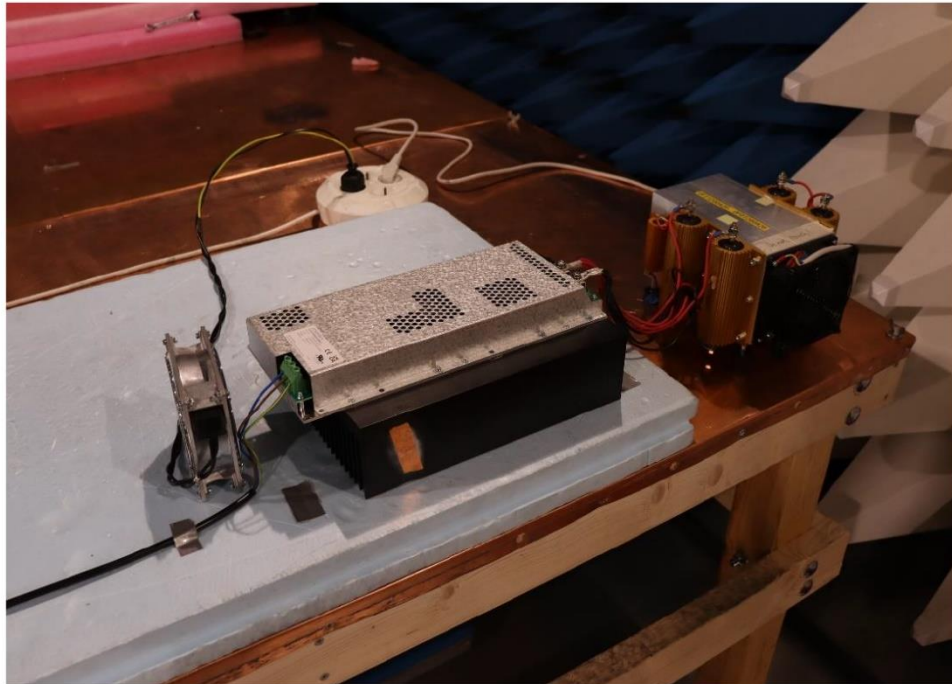

Fig. 16.5 MIL-STD-461F CE102 test environment

17. Figure of Test Circuitry

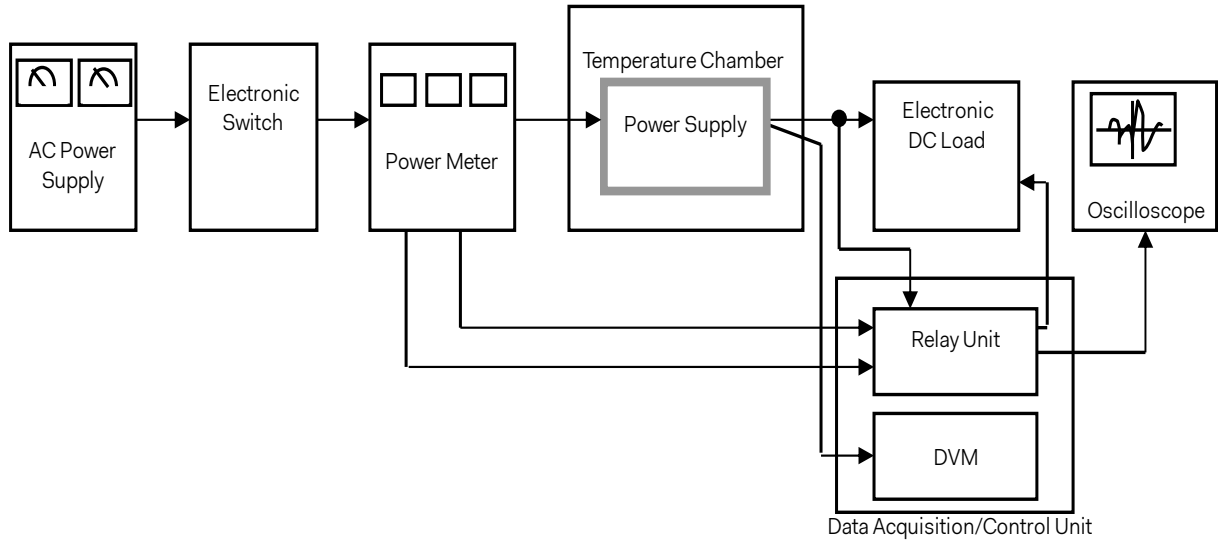

Figure A Test circuitry for general performance measurement

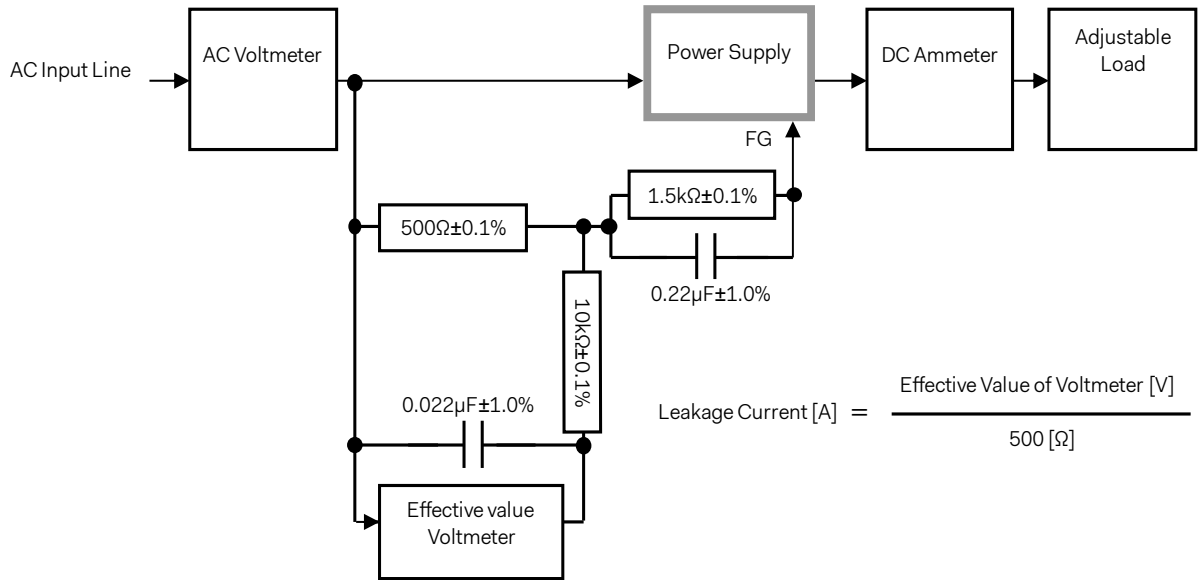

Figure B-1 Leakage current measurement (IEC62368-1, refer to IEC60990 Fig.4)

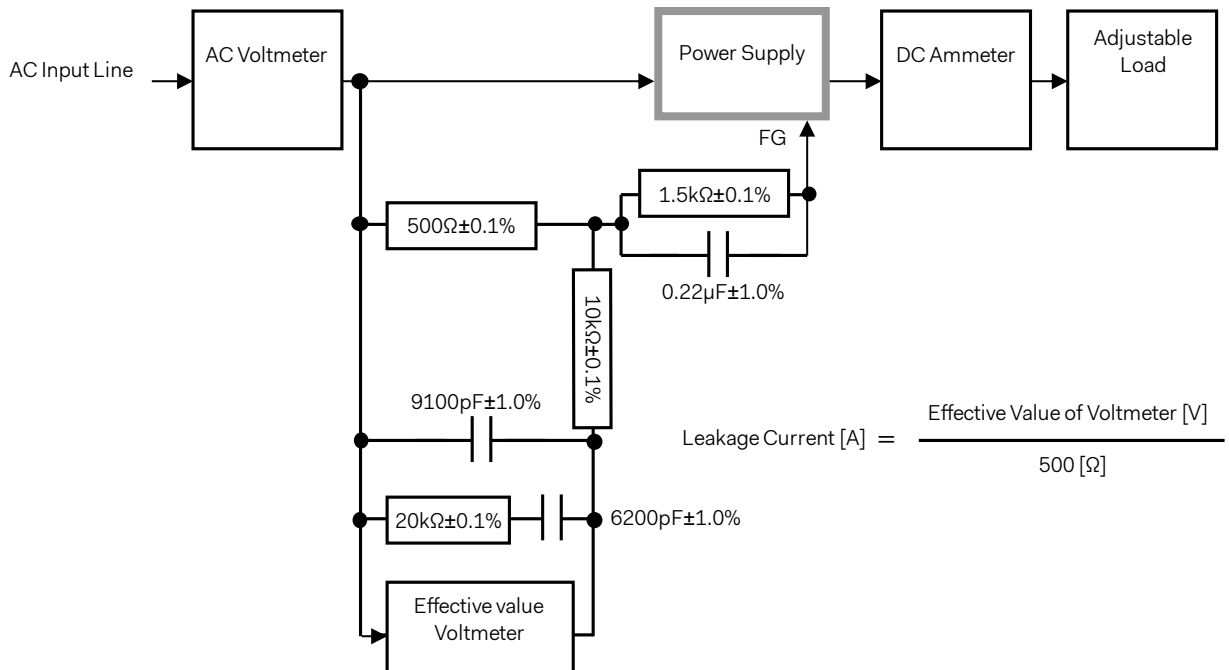

Figure B-2 Leakage current measurement (IEC62368-1, refer to IEC60990 Fig.5)

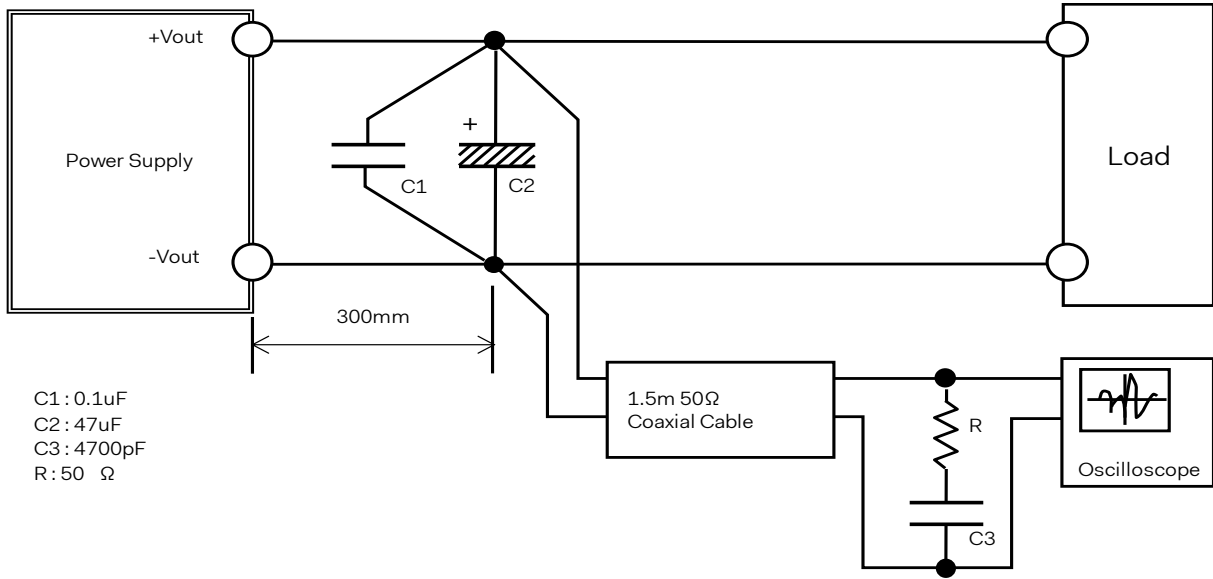

Figure C Ripple voltage measurement (JEITA RC-9131D)

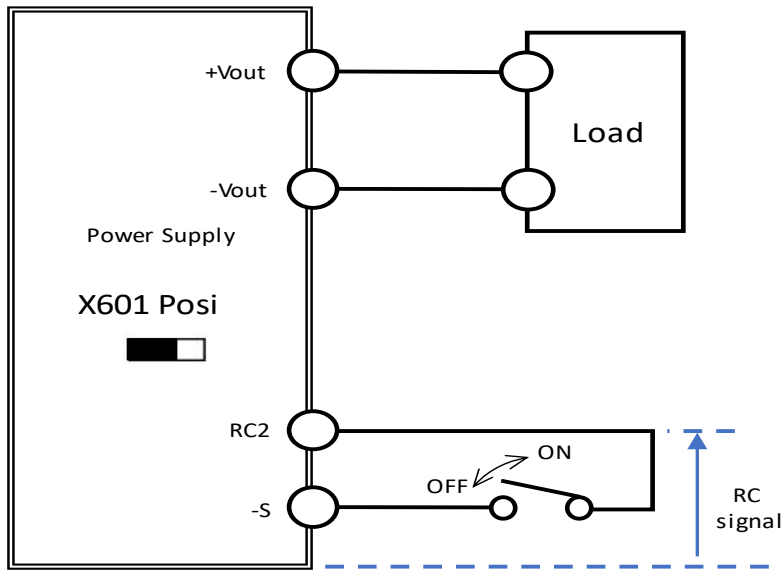

Figure D Turn on by RC measurement