

Table of Contents

1.	Assembling and Installation Method	1
1.1	Mounting method	1
1.2	Isolation from conductive enclosure.....	2
1.3	Installation to fulfil EMC requirement.....	2
2.	Derating.....	2
2.1	Derating curve by input voltage.....	2
2.2	Derating curve by ambient and baseplate temperature.....	2
3.	Wiring	3
3.1	Wiring input connector	3
3.2	Wiring output terminal	3
3.3	Wiring function connector.....	3
3.4	Jumper factory setting	3
3.5	Output ripple and ripple noise measurement	4
4.	Functions	4
4.1	Input voltage range	4
4.2	Inrush current limiting	4
4.3	Over current protection.....	4
4.4	Over voltage protection.....	4
4.5	Thermal protection	4
4.6	Output voltage adjustment.....	4
4.7	Remote ON/OFF	5
4.8	Remote sensing.....	6
4.9	Adjustable constant current range	7
4.10	Power good (PG).....	7
5.	Series / Parallel Operation.....	8
5.1	Series operation	8
5.2	Parallel operation	8
5.3	Redundancy operation.....	10
5.4	Output current monitor.....	10
6.	Life Expectancy and Warranty	11
6.1	Life Expectancy	11
6.2	Warranty	11
7.	Options.....	11
7.1	Option -O: with Active ORing (For only 28V and 48V).....	11

1. Assembling and Installation Method

1.1 Mounting method

OFD1200A series should be mounted to a heatsink or enclosure which has sufficient thermal capacity to be cooled by conduction cooling.

OFD1200A has 12 of 4.5mm diameter mounting holes, to keep uniform thermal conductivity, use all holes as shown in Fig. 1.1.

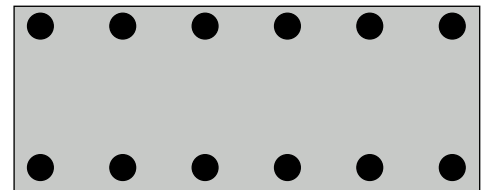

Fig. 1.1 Mounting hole requirement

A thermal interface material such as thermal pads or thermal grease shall be used to ensure proper cooling of the power supply.

OFD1200A28 and OFD1200A48 without option -O (Active ORing), and OFD1200A65 have open holes in the aluminium baseplate. When using grease as thermal interface material, it could flow to the inside of unit. This is not dangerous, but not desirable. We recommended to not apply grease closer than 10mm from these holes. See Fig. 1.2 for location of open holes.

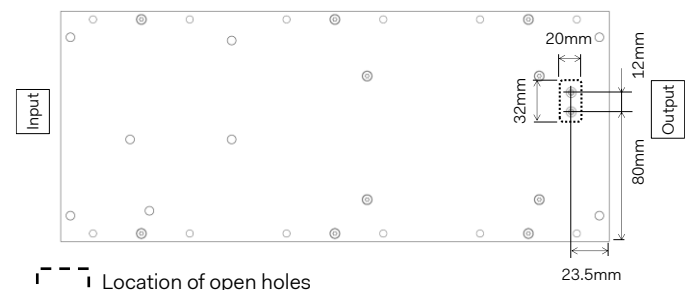

Fig. 1.2 The Location of open hole on aluminium baseplate (Bottom view)

Remarks:

- There are no open holes in the aluminium baseplate on some models. Please refer to Table 1.1 to clarify the differences.

Table 1.1 Holes on the baseplate by models

Model	Holes
OFD1200A12-N	No holes
OFD1200A28-NO	No holes
OFD1200A28-N	Holes
OFD1200A48-NO	No holes
OFD1200A48-N	Holes
OFD1200A65-N	Holes

1.2 Isolation from conductive enclosure

There are dangerous voltages inside of the unit. Special attention needs to be considered when installing the unit.

Ensure proper isolation distances between the components and conductive enclosure.

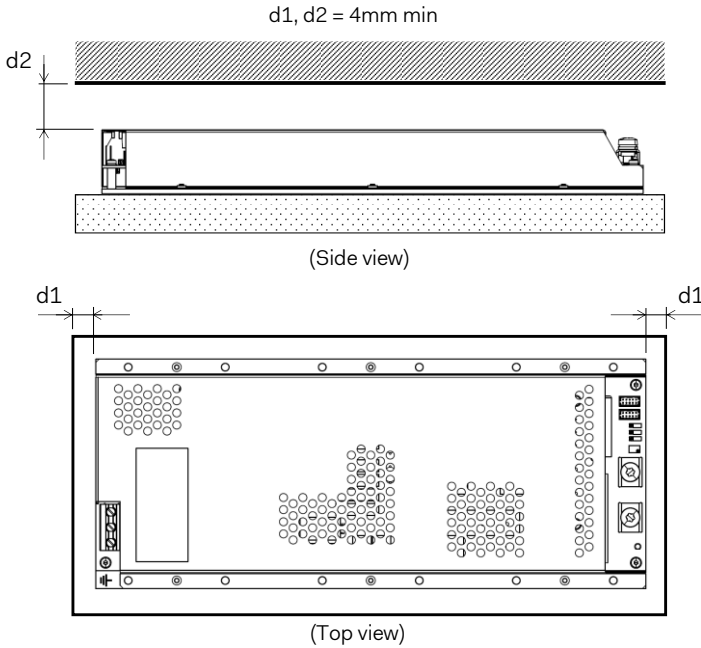

Fig. 1.3 Isolation distance

To optimize cooling airflow around the unit, ensure that the clearance between the unit and surrounding objects is as large as possible.

1.3 Installation to fulfil EMC requirement

To ensure the best EMI-performance, the equipment should be mounted inside an earthed metal box. If it is not possible, install the unit and the load on an earthed metal plate.

Input cables should be twisted and placed as close to the metal enclosure as possible.

Output cables of positive (+) and negative (-) should be twisted and shall be separated from input cables as much as possible.

If radiation from input or output cables are an issue, use appropriate EMC ferrite clamp on the cables.

When function pins are connected to a user accessible point (i.e., panel switch, indicator circuit etc.), these must be protected from electrostatic discharging.

2. Derating

2.1 Derating curve by input voltage

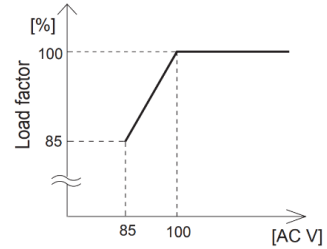

Fig. 2.1 Derating curve by input voltage

Remarks:

- OFD1200A12-N has no input voltage derating.
- The over current protection will be activated as following Fig.2.1.

2.2 Derating curve by ambient and baseplate temperature

For reliable and safe operation, follow the derating curve shown in Fig. 2.2 and Fig. 2.3. The measurement point of baseplate is shown in Fig. 2.4. The curve is set based on 3-years life expectancy.

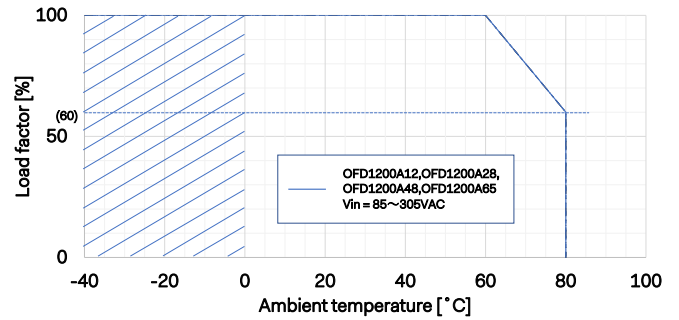

Fig. 2.2 Derating curve by ambient temperature

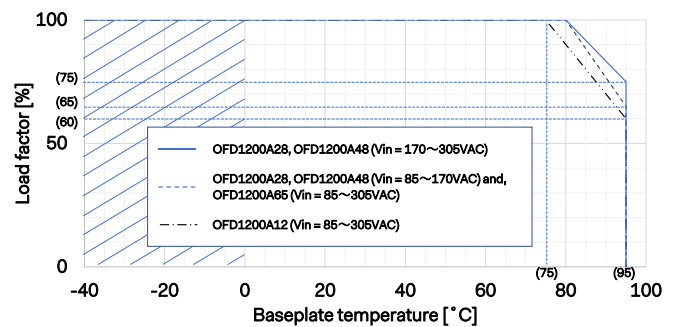

Fig. 2.3 Derating curve by baseplate temperature

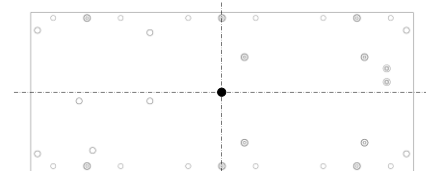

Fig. 2.4 Measurement point of baseplate (Bottom view)

Remarks:

Operation in the hatched defers level of the ripple and noise.

3. Wiring

3.1 Wiring input connector

(1) Built-in fuse

The two 16A AC fuses are built-in on AC(L) in parallel.

(2) Wire

Connection capability of the input connector.

Input connector type	: MKDS 5/ 3-9,5 (1714984) (Phoenix Contact)
Connector cross section solid	: 0.2 mm ² – 6 mm ²
Connector cross section flexible	: 0.2 mm ² – 4 mm ²
Conductor cross section (AWG)	: AWG 24 – 10
Conductor cross section (flexible, with ferrule)	: 0.25 mm ² – 4 mm ²
Stripping length	: 8mm
Torque	: 0.5 – 0.6 Nm

An input current is dependent on input voltage and output current. Choose the appropriate thickness for the input wire.

Influence against noise is improved if the input wires are twisted. In addition, make sure that input and output wires are separated.

(3) FG terminal

The FG terminal on input connector shall be Functional Ground. Make sure that the mounting hole for protective earthing on the baseplate is properly connected, as required for class I equipment.

3.2 Wiring output terminal

The assembly torque for output terminal screws.

Screw size	: M6
Recommended screw torque	: 3.8 Nm

At -40°C operation, an external output capacitor needs to be added to ensure stable output voltage during start-up. Table 3.1 shows a recommended external output capacitor.

Table 3.1 Recommended external output capacitor

Models	Value
OFD1200A12-N	7,800 μF
OFD1200A28-N and -NO	3,000 μF
OFD1200A48-N and -NO	1,360 μF
OFD1200A65-N	Not needed

3.3 Wiring function connector

Fig. 3.1 shows the pin assignment and Table 3.2 states the pin configuration of function connector X506 and X507.

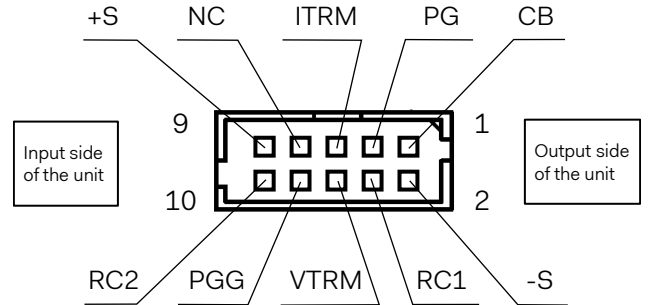

Fig. 3.1 X506 and X507 Pin assignment

Table 3.2 Function of connector X506 and X507

Pin No.	Name	Function
1	CB	Refer to Section 5.2
2	-S	Refer to Section 4.8
3	PG	Refer to Section 4.10
4	RC1	Refer to Section 4.7
5	ITRM	Refer to Section 4.9
6	VTRM	Refer to Section 4.6
7	NC	
8	PGG	Refer to Section 4.10
9	+S	Refer to Section 4.8
10	RC2	Refer to Section 4.7

<Connector information>

Part number : 87831-1041 (Molex)

<Appropriate mating connector and pin>

Part number : 51110-1056 (Molex)

Pin : 50394-8051 (Molex)

For connecting X506 and X507, optional cable H-SN-61 (Manufactured by Cosel) is available.

<https://en.cosel.co.jp/product/optionparts/H-SN-61/>

Remarks:

- An incorrect connection of functional connector may cause damage on an internal circuit. Make sure the connection is properly made.

3.4 Jumper factory setting

Jumpers on X503, X504 and X601 are placed as shown in Fig. 3.2 at the factory.

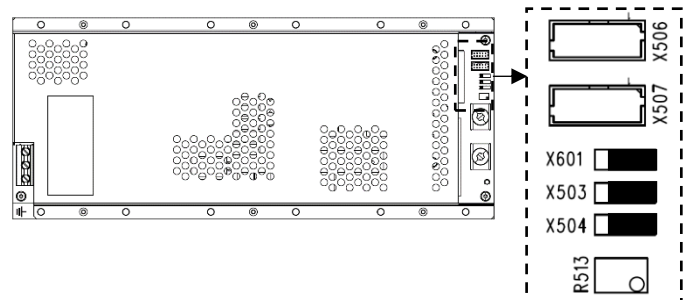

Fig. 3.2 Jumper placement at factory

3.5 Output ripple and ripple noise measurement

The specified ripple and ripple noise are measured by the method shown in Fig.3.3.

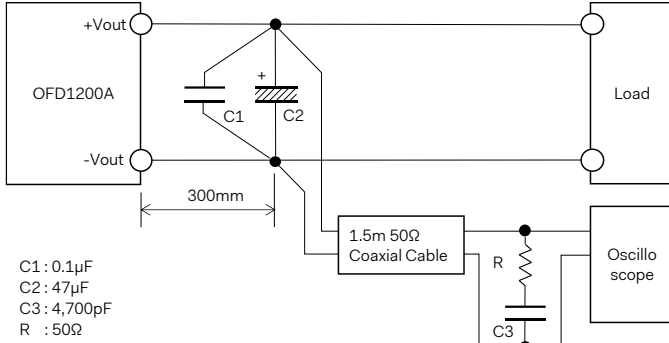

Fig.3.3 Method of Measuring Output ripple and ripple noise

Remarks:

- When the ambient temperature is lower than -20°C, the output ripple may become unstable during heating up.

4. Functions

4.1 Input voltage range

The unit operates with an input voltage range between 85 - 305 VAC. The voltage range for a valid safety approval is 100 - 277 VAC (50/60Hz).

Remarks:

- Be aware that use of voltages other than those listed above may result in the unit not operating according to specifications or may cause damage or dangerous situations. Avoid square waveform input voltage, commonly used in UPS and inverters.

4.2 Inrush current limiting

There is a built-in inrush current limiting circuit.

If a switch is needed on the input side, select one that can withstand the input inrush current.

The thyristor technique is used in the inrush current limiting circuit. Avoid repeatedly turning the power ON/OFF within a short period of time, operates the inrush current limiting becomes inoperative.

When the input power is turned on, the primary inrush current and secondary inrush current will be generated due to the thyristor technique used for the inrush current limiting circuit.

4.3 Over current protection

The over current protection is built in and comes into effect when drawing over 105% of the rated current.

The over current protection prevents the unit from short circuit and over current condition. The unit automatically recovers when the fault condition is cleared.

When the output voltage drops at over current, the average output current is reduced by hiccup operation of the unit.

4.4 Over voltage protection

The over voltage protection circuit is built in. If the over voltage protection circuit is activated, shut down the input voltage, wait a certain time and turn on the AC input again to recover the output voltage.

The recovery time is 10 seconds or more.

Remarks:

- Note that devices inside the unit might fail if voltage of higher than rated output voltage is applied to output terminal. This could happen when the user tests the over voltage performance of the unit.

- With option -O (Active ORing) circuit disconnects the output from the external voltage. Therefore, over voltage protection will not be activated. Therefore, it is not possible to test over voltage performance for an option -O unit by applying external voltage.

4.5 Thermal protection

When the baseplate temperature exceeds the maximum temperature, thermal protection will be activated and shut down the output.

When the thermal protection is activated, turn off the input voltage and eliminate all the overheating conditions. To recover the output voltage, let the unit cool down before turning on the input voltage again.

4.6 Output voltage adjustment

The output voltage can be adjusted by means of either the built-in potentiometer (R513) or by applying an external voltage source.

(a) Adjustment by built-in potentiometer

To increase output voltage, turn R513 clockwise. To decrease the output voltage, turn it counterclockwise.

The output voltage adjustment range by R513 is shown below.

Model Number	Output Voltage adj.
OFD1200A12-N	4.2 - 14.4VDC
OFD1200A28-N and -NO	9.8 - 33.6VDC
OFD1200A48-N and -NO	16.8 - 57.6VDC
OFD1200A65-N	22.8 - 78.0VDC

(b) Adjustment by external voltage source

To adjust the output voltage by an external voltage source, apply it between VTRM and -S terminal.
 Use a low impedance source as external voltage. The internal circuit of VTRM is shown in Fig. 4.1.

The output voltage adjustment range by external voltage source is shown below.

Model Number	Output Voltage adj.
OFD1200A12-N	0 - 14.4VDC
OFD1200A28-N and -NO	0 - 33.6VDC
OFD1200A48-N and -NO	0 - 57.6VDC
OFD1200A65-N	0 - 78.0VDC

WARNING:

Adjusting the built-in potentiometer (R513) fully counterclockwise and applying external voltage may damage the unit.

The output voltage must be adjusted within ±20% of the nominal by R513 before applying external voltage.

Do not apply an external voltage lower than -0.3V or greater than 5.0V.

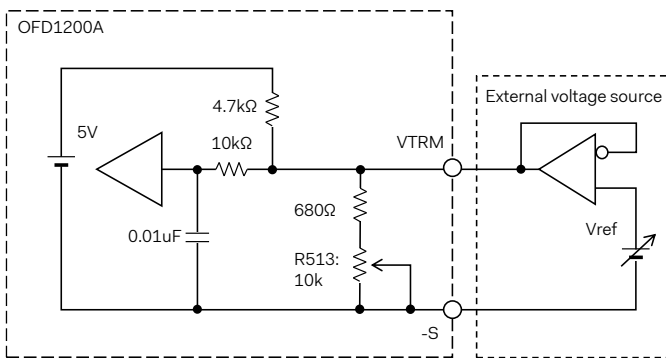

Fig. 4.1 VTRM internal circuit

The output voltage can be calculated by the following equation when the voltage is applied to the VTRM terminal.

$$\text{Output voltage [V]} = \frac{\text{The voltage between VTRM and -S [V]}}{2.5 \text{ [V]}} \times \text{Rated output voltage [V]}$$

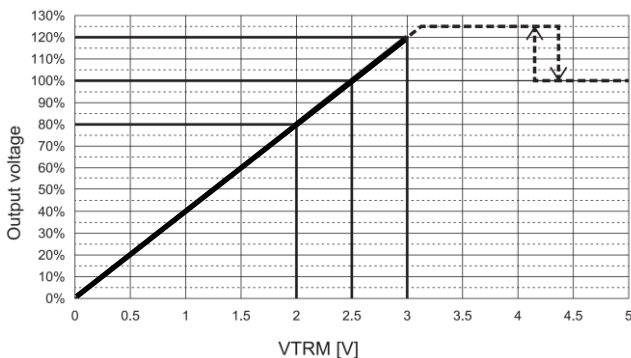

Fig. 4.2 Output Voltage by VTRM

4.7 Remote ON/OFF

Remote ON/OFF is built in. Remote ON/OFF is operated by applying a voltage between RC1 and RC2 terminal. The Internal circuit and function of X601 are shown in Fig. 4.3.

When the output shuts off by the over voltage protection or thermal protection, it can be recovered by toggling Remote ON/OFF signal.

The remote control logic can be changed with X601. And the isolation between the RC circuit and any other is dependent on the position of X601's jumper. Those details are shown in Table 4.1 and Fig. 4.4.

Table 4.1 Remote Control Logic

No.	Item	Remote Control Logic		
1	Connection method	Fig. 4.4(a)	Fig. 4.4(b)	Fig. 4.4(c)
2	Isolation	INPUT - RC OUTPUT - RC	INPUT - RC	INPUT - RC
3	Reference pin	RC2	-S	-S, RC2
4	Output ON	SW OPEN (0.1mA max)		SW SHORT (0.5V max)
5	Output OFF	SW SHORT (2mA min)		SW OPEN (0.1mA max)

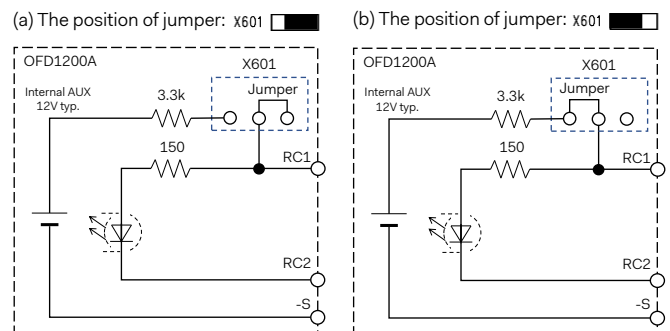
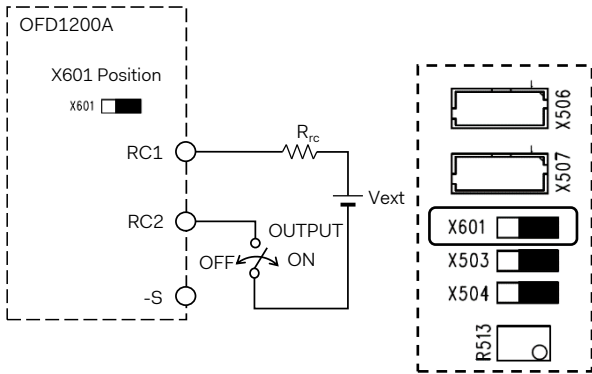

Fig. 4.3 The Internal circuit and function of X601

(a) Use external voltage source (Positive logic)



External resistor R_{rc} value shall be decided by following formula.

$$\frac{V_{ext}[V]-1.4}{2[mA]} - 150[\Omega] > R_{rc}[\Omega] > \frac{V_{ext}[V]-0.9}{12[mA]} - 150[\Omega]$$

(b) Change position of X601 (Positive logic)

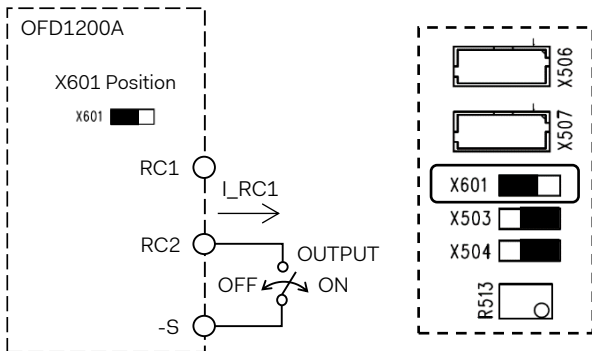

In the case of this connection example, the control current (I_{RC1}) flows up to 3.5mA.

(c) Change position of X601 (Negative logic)

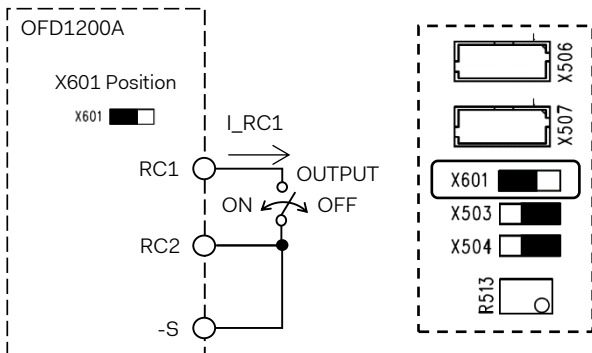

In the case of this connection example, the control current (I_{RC1}) flows up to 3.5mA.

Fig. 4.4 Example of connecting remote ON/OFF circuit

Remarks:

- Be careful not to connect RC1 and RC2 opposite. It may cause a failure of unit.
- The sink current of RC1 must be kept up to 12mA.
- Do not use RC1 terminal any other purposes except remote control.

4.8 Remote sensing

Remote sensing is built in. When remote sensing is not used, make sure that jumpers are placed on X503 and X504 as shown in Fig. 4.5(a).

When using remote sensing function, place jumpers on X503 and X504 as shown in Fig. 4.5(b), then connect +S and -S terminal on X506 or X507 to sensing point.

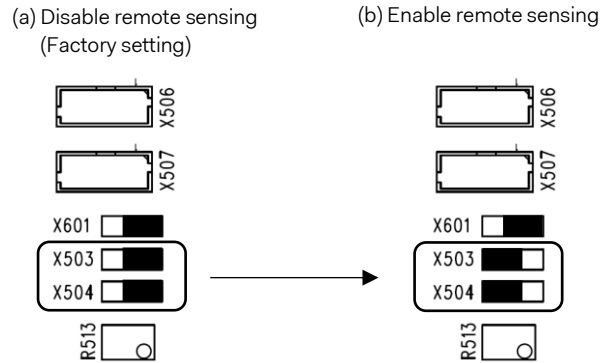

Fig. 4.5 X503 and X504 Jumper position

Remarks:

- Twisted-pair wires or shielded wires should be used for sensing wire.
- Use proper cable thickness for the wiring between the unit and load. The line drop between the unit and load should be less than 0.5V. The voltage between +Vout and -Vout should remain within the output voltage adjustment range.
- If the sensing lines become short circuited, a high current will occur, and the sensing circuit may be damaged. The problem can be prevented by installing current limiting the component near the load.
- As wiring or load impedance may generate oscillation or large fluctuation in output voltage, make sure enough evaluation is given in advance. If the unstable condition occurs, try adding C1 - C3 and R1.

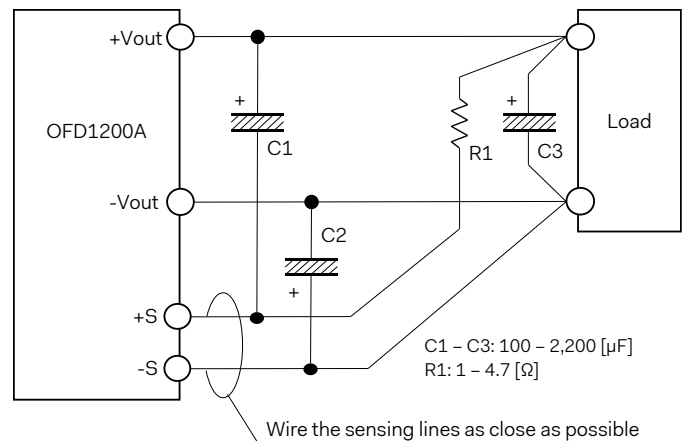

Fig. 4.6 When using remote sensing function

4.9 Adjustable constant current range

The output current for the constant current can be adjusted by connecting external resistors to ITRM or by applying a voltage externally. Meanwhile, the Hiccup mode of the short circuit protection will be disabled.

(1) Constant current adjustment by potentiometer

By connecting the external potentiometer as shown in Fig. 4.7, output current for constant current becomes adjustable.

Wiring to the potentiometer should be as short as possible. As the ambient temperature fluctuation characteristics deteriorate depending on the types of resistors and potentiometers, use resistors and a potentiometer of the following specifications:

Potentiometers: Cermet type, coefficient less than $\pm 300\text{ppm}/^\circ\text{C}$

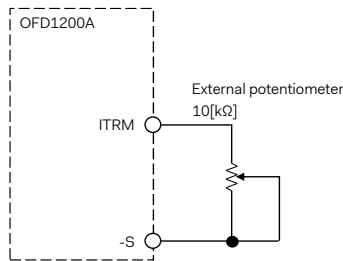

Fig. 4.7 Connection for CC by external potentiometer

(2) Constant current adjustment by external voltage

By applying a voltage externally to ITRM, output current for constant current becomes adjustable.

When the ITRM terminal voltage is set at less than 2.5 V, the constant current set value can be changed.

$$\text{Output current [A]} = \frac{\text{The voltage between ITRM and -S [V]}}{2.5 \text{ [V]}} \times \text{Rated output current [A]}$$

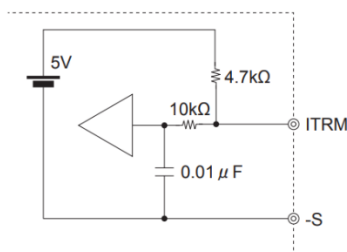

Fig. 4.8 ITRM internal circuit

Remarks:

- If the output voltage becomes less than 5% of the rated voltage during constant current operation, the output voltage may become unstable.

- When the output current adjustment is not used, keep ITRM pin open.

- Do not set the external applied voltage to -0.3 V or less, and 5.0 V or more.

4.10 Power good (PG)

By using power good signal (PG), it is possible to monitor the unit whether normal operation or abnormal operation. The PG signal is "Low" when the unit operates correctly. The signal turns to "High" when the unit stops.

The PG circuit is designed as shown in Fig. 4.9. The sink current of PG is 1mA max.

The circuit of the PG (PG, PGG) is isolated from input, output, FG, and various function terminals.

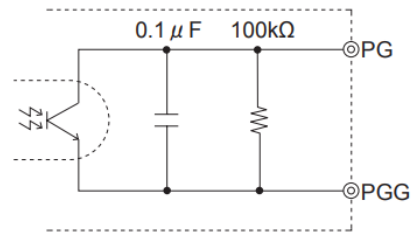
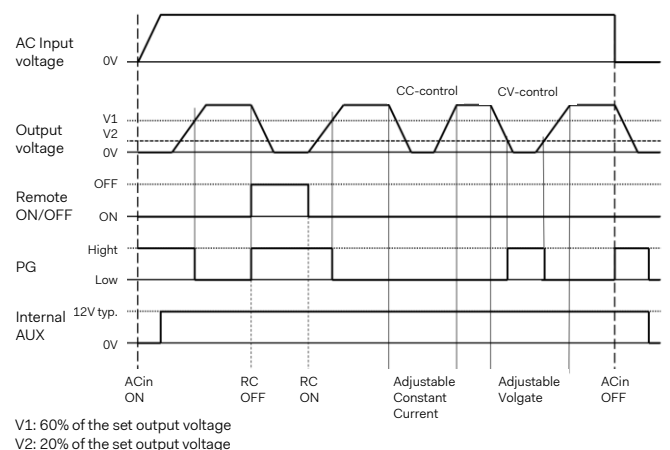

Fig. 4.9 Internal circuit of PG

The details of PG signal are shown in Table 4.3, Fig. 4.10, and Fig. 4.11.

Table 4.3 Specification of PG

No.	Item	PG
1	Function	Normal operation "Low"
		The unit stops "High"
2	Base pin	PGG
3	Level voltage "L"	0.5V max at 1mA
4	Level voltage "H"	Open collector
5	Maximum sink current	1mA max
6	Maximum applied voltage	50V max



V1: 60% of the set output voltage
 V2: 20% of the set output voltage

Fig. 4.10 PG signal sequence

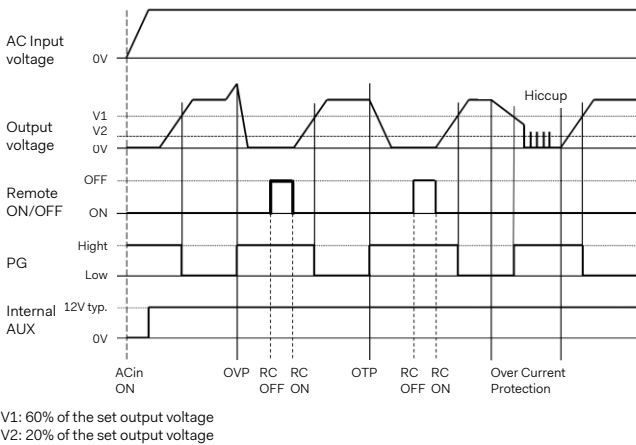

Fig. 4.11 PG signal sequence with circuit protections

5. Series / Parallel Operation

5.1 Series operation

Series operation is possible by connecting the output of two or more power supplies as shown in Fig. 5.1.

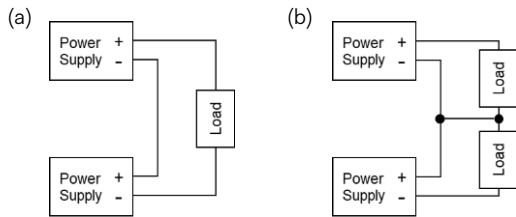

Fig. 5.1 Example of Series operation

Output current in series connection should be lower than the lowest rated current in each unit.

When one of unit's output becomes short circuit in series operation, high voltage may be applied to rest of units. To avoid further damages, consider adding a protection method that immediately stops operation.

Make sure that the combined total output voltage is less than 120Vdc.

The classification of Electrical energy source of output voltage for OFD1200A12 and OFD1200A28 are ES1, and OFD1200A48 and OFD1200A65 are ES2. Therefore, make sure the safety requirement when total output voltage exceeds 60Vdc.

5.2 Parallel operation

(a) Wiring for parallel operation

Parallel operation is possible by connecting the units as shown in Fig. 5.2 and Fig. 5.3. Terminal -S, CB, and VTRM of function connector X506 or X507 of each unit must be connected to each other.

To wire the terminal -S, the jumper position of X504 must be changed for all units as Fig. 5.2 and then, the cable must be connected to -Vout from only one unit shown as Fig.5.3. The cables must be twisted or bundled with a cable of CB and VTRM. If not, the output voltage may become unstable or fluctuate.

If the temperatures of aluminium baseplate are different in the unit in parallel operation, the difference of output current becomes large. Consider the thermal design to equalize aluminium baseplate temperatures. (i.e., attaching a single heatsink etc.)

Total current must not exceed the value calculated by the following equation, and total number of units should be no more than 9 pieces.

(Output current at parallel operation)

$$= (\text{the rated current per unit}) \times (\text{number of unit}) \times 0.9$$

(a) Factory setting



(b) For wiring parallel operation

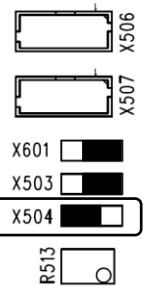

Fig. 5.2 X504 Jumper position

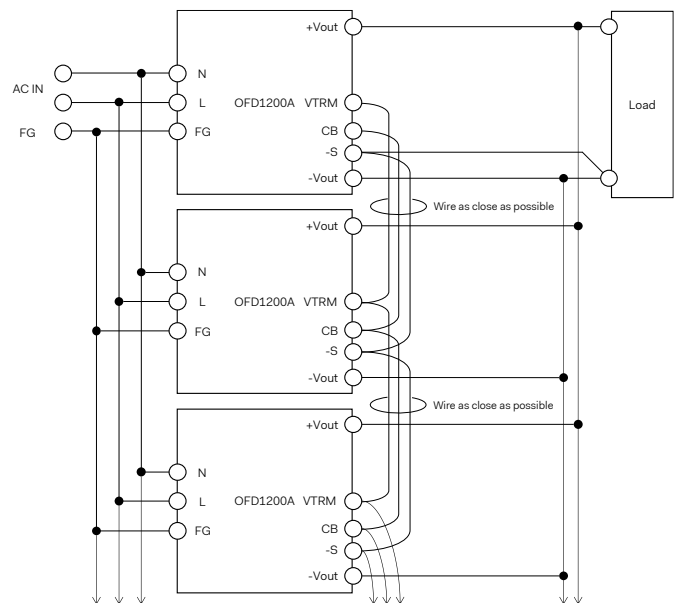

Fig. 5.3 Example of wiring for parallel operation

Remarks:

- Make sure that the wiring impedance of a load from each unit becomes even.
- A voltage drop from -Vout of unit to the connected point of terminal -S should be less than 0.5V for stable control.
- If the output current is less than 2% of the rated current, the output voltage ripple will be large.
- If all paralleled unit need to start up at the same time, remote control function shall be used.

(b) Output voltage adjustment in parallel operation

The output voltage can be adjusted by the built-in potentiometer (R513) or by applying an external voltage source in parallel operation.

By using R513, it is possible to adjust all output voltages in the unit by the master unit. Select one unit as the master and turn the R513 of the other unit (slave) clockwise to the maximum output voltage adjustment following the datasheet.

By using an external voltage source, the examples of circuits are shown in Fig. 5.4. Refer to section 4.6 "Output voltage adjustment" how to use this function.

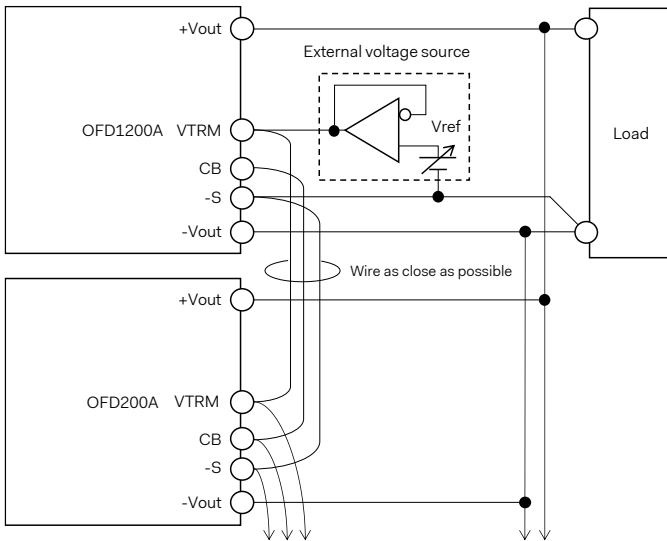

Fig. 5.4 Example of connecting output voltage adjustment circuit with external voltage in parallel operation

(c) Wiring for parallel operation with remote sensing

Example of connecting remote sensing circuits in parallel operation are shown in Fig. 5.5. Refer to section 4.8 "Remote sensing" how to use this function.

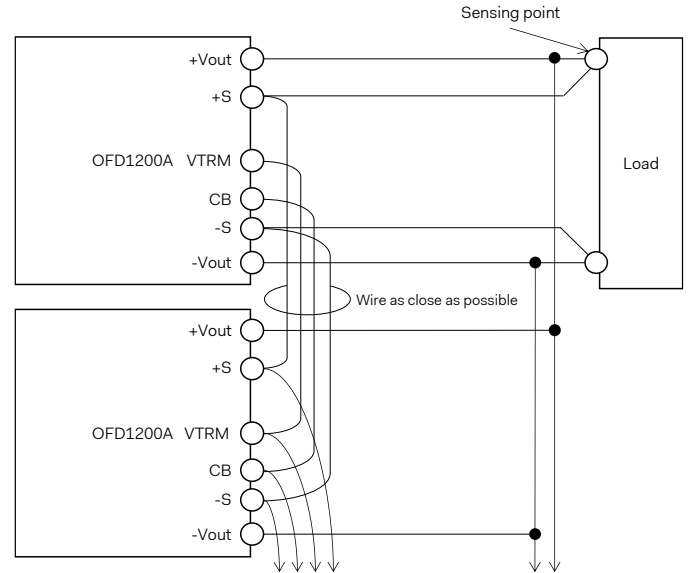

Fig. 5.5 Example of connecting remote sensing circuit

(d) Wiring for parallel operation with remote control

Example of connecting remote ON/OFF circuits in parallel operation are shown in Fig. 5.6 and Fig. 5.7. Refer to section 4.7 "Remote ON/OFF" how to use this function.

In this case, accumulated current ($N \times I_{RC1}$) flows to the control switch.

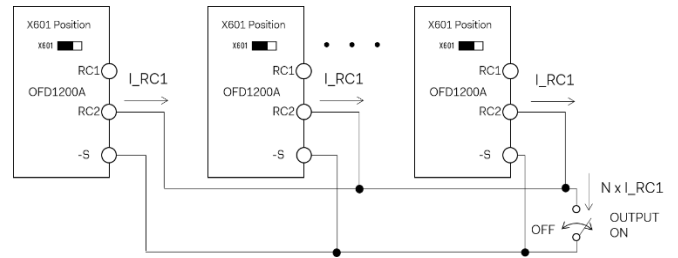

Fig. 5.6 Example of connecting remote ON/OFF circuit

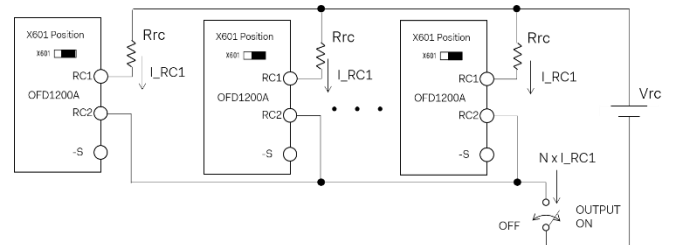

Fig. 5.7 Example of connecting remote ON/OFF circuit

(e) Wiring for parallel operation with constant current adjustment
 The constant current adjustment can be used in parallel operation. By changing the ITRM voltage of one unit, the constant current adjustable for all of units.
 It is not necessary to connect the ITRM terminals together. Examples of connecting constant current circuit in parallel operation are shown in Fig. 5.8 and Fig. 5.9. Refer to section 4.9 "Adjustable constant current range " how to use this function.

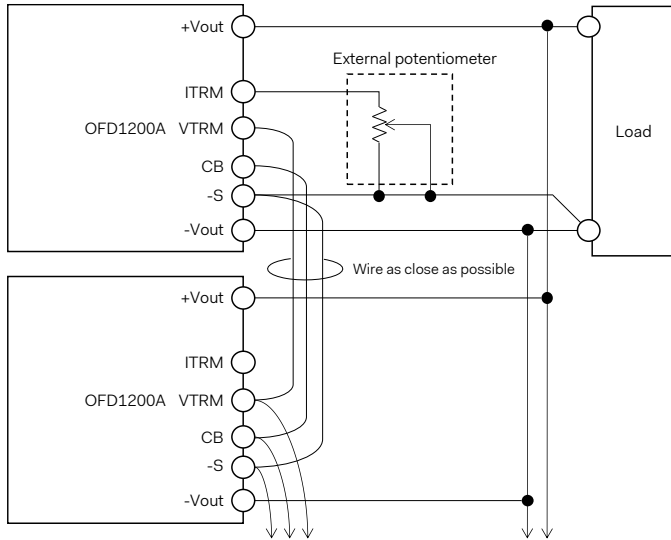

Fig. 5.8 Example of connecting constant current circuit with a potentiometer

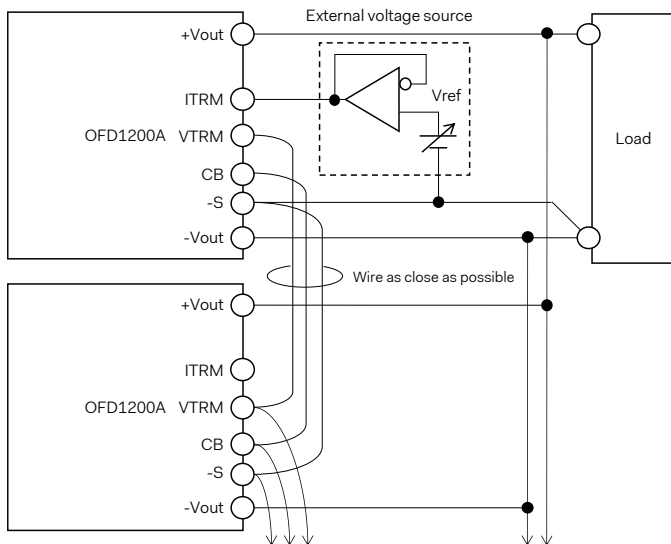

Fig. 5.9 Example of connecting constant current circuit with an external voltage

5.3 Redundancy operation

By choosing option -O, ORing MOSFET is implemented into the unit. Therefore, it is possible to connect each output directly for N + 1 redundancy operation. See section 7.2.

5.4 Output current monitor

The output current can be monitored by measuring the voltage between the CB and -S terminal. Fig. 5.10 shows the relationship between the voltage of CB terminal and the output current.

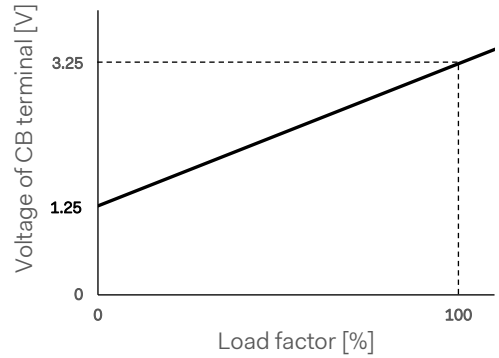

Fig. 5.10 CB terminal voltage vs output current

The output current shown in Fig. 5.10 is for reference only. Output current monitor circuit example is shown in Fig. 5.11.

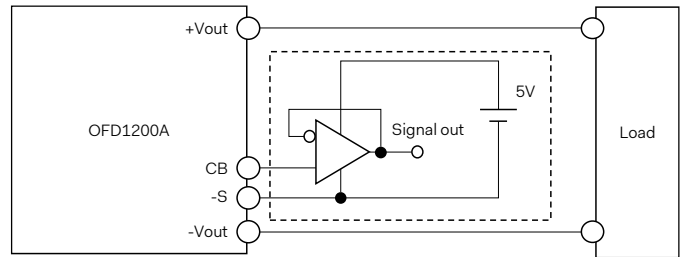

Fig. 5.11 Example of monitoring circuit

- Use a measuring instrument whose input impedance is 500kΩ or higher
- Do not connect more than 0.01μF between the CB and -S terminal to prevent output voltage malfunction.
- Wire carefully to avoid malfunction caused by noise.
- The pulse load cannot be monitored.

6. Life Expectancy and Warranty

6.1 Life Expectancy

A life expectancy is strongly dependent to operating temperature and cooling conditions.

To make sure the life expectancy, measure temperature of Electrolytic capacitors shown in Fig. 6.1 and calculate by following formula.

$$L = L_{105} \times 2^{\frac{105 - T_{cap}}{10}}$$

where

L : Life expectancy [hour]

L₁₀₅ : Endurance at 105°C [hour], see table 6.1

T_{cap} : Temperature of Electrolytic capacitor [°C]

Table 6.1 Endurance of Electrolytic capacitor

Item		C405	C501
L ₁₀₅	Endurance at 105 [°C]	12,000h	8,000h

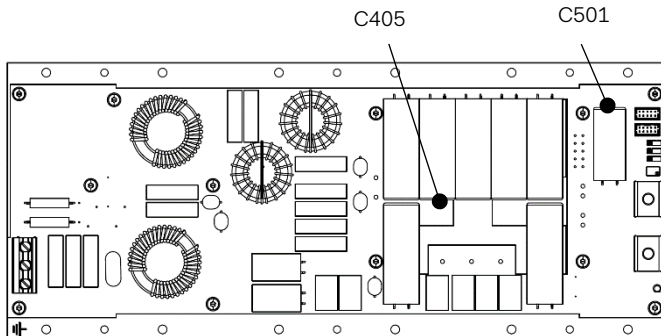

Fig. 6.1 Temperature measuring point for Life expectancy

To measure a temperature of internal components in the units, it is necessary to remove the cover to apply thermocouples on measuring points.

To remove the cover, remove cables from the input terminal and remove 6 screws from the bottom of the baseplate referring to Fig. 6.2. There are an isolation sheet and thermal pads on the input filter. When the cover is re-installed, make sure that the isolation sheet and thermal pads are properly located.

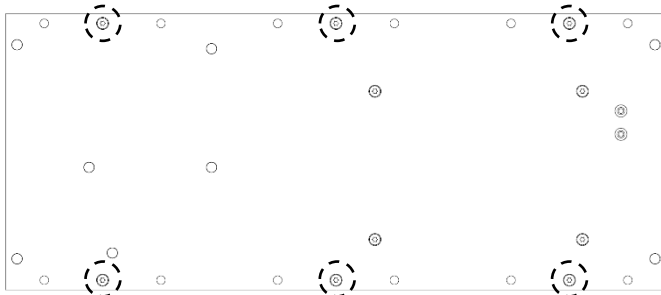

Fig. 6.2 Screws to be removed for temperature measurement

6.2 Warranty

Warranty term is 3 years.

7. Options

7.1 Option -O: with Active ORing (For only 28V and 48V)

ORing MOSFET is implemented. It enables to connect each output of same model to use as redundancy operation without additional components. The differences between with/without option -O are shown below.

(a) Adjustment by external voltage source

The output voltage adjustment range by external voltage source with the option -O is shown as below.

Model Number	Output Voltage adj.
OFD1200A28-O and -NO	1 - 33.6VDC
OFD1200A48-O and -NO	1 - 57.6VDC

WARNING:

With option -O, adjusting the output voltage to less than 1V or using the constant current adjustment function under an output voltage less than 1V may cause unstable operation or heat up internal ORing MOSFET.

(b) Parallel and N + 1 Redundancy operation

Parallel operation and N + 1 redundancy operation are possible with option -O.

In this operation, the remote sensing and constant current function cannot be used. Otherwise, the redundancy will not be working on failed condition with using those functions.

If those functions are needed, choose the standard model of OFD1200A.

Wiring for parallel and N + 1 redundancy operation, follow Fig. 5.3. Even though the remote sensing function is not used, terminal -S must be wired with an appropriate connection.

Remarks:

- To adjust the output voltage by the built-in potentiometer (R513), the output voltage setting of each unit must be equalized. Otherwise, the output voltage might be changed to unintentional voltage in case one or more units failed.

- When choosing option -O for N + 1 redundancy, make sure that the total output current does not exceed the rated current of a single unit.

- When replacing one or more units in N + 1 redundant operation, the input voltage must be shut out. A hot swap is not supported for OFD1200A.