

EVALUATION DATA

MODEL NAME : OFD1200A48

Tested by : *Shintaro Oki*
Shintaro Oki

Approved by : *Tomas Isaksson*
Tomas Isaksson

P R

B X

POWERBOX
A Cosel Group Company

Table of Contents

1. Input Current (by Load Current)	3
2. Efficiency (by Load Current).....	3
3. Power Factor (by Load Current)	4
4. Leakage Current	4
5. Inrush Current	5
6. Line Regulation	6
7. Load Regulation	6
8. Ripple Noise.....	7
9. Dynamic Load Response	7
10. Rise Time Characteristics by AC ON	8
11. Rise Time Characteristics with RC Signal.....	8
12. Fall Time / Hold-up Time	9
13. Over Current Protection	10
14. Minimum Input Voltage for Regulated Output Voltage	11
15. Over Voltage Protection	11
16. Conducted Emission	12
17. Figure of Test Circuitry	15

Remark:

Unless specified the test condition shall be

Input voltage / Frequency: 230 [Vac] / 50 [Hz]

Load current: 25.0 [A]

Baseplate temperature: 25 [°C]

1. Input Current (by Load Current)

Test Circuitry : Figure A

Graph

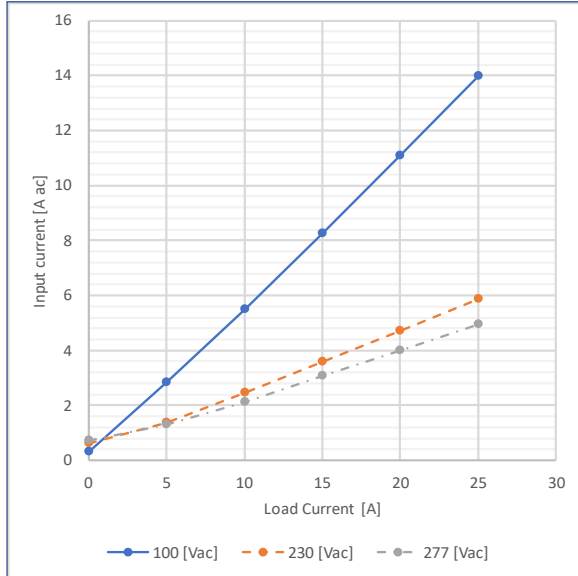

Value

Load Current [A]	Input Current [Aac]		
	Input Voltage		
	100 [Vac]	230 [Vac]	277 [Vac]
0.00	0.299	0.607	0.716
5.00	2.820	1.377	1.285
10.00	5.501	2.449	2.133
15.00	8.265	3.573	3.056
20.00	11.069	4.718	3.999
25.00	13.969	5.882	4.951

2. Efficiency (by Load Current)

Test Circuitry : Figure A

Graph

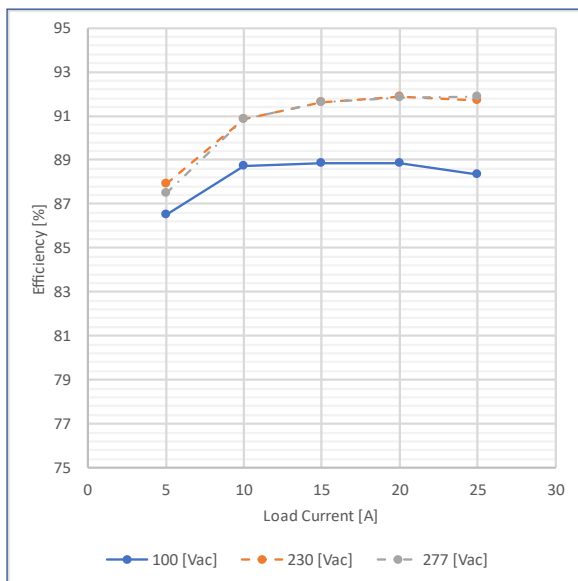

Value

Load Current [A]	Efficiency [%]		
	Input Voltage		
	100 [Vac]	230 [Vac]	277 [Vac]
0.00	-	-	-
5.00	86.501	87.933	87.468
10.00	88.703	90.838	90.858
15.00	88.856	91.619	91.602
20.00	88.832	91.860	91.823
25.00	88.353	91.724	91.863

3. Power Factor (by Load Current)

Test Circuitry : Figure A

Graph

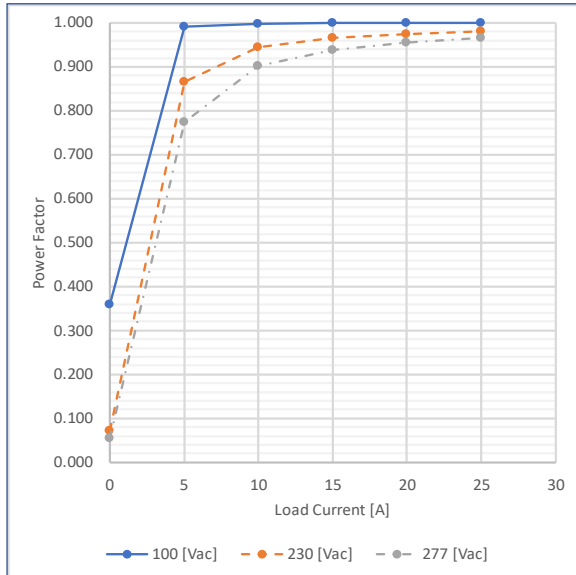

Value

Load Current [A]	Power Factor		
	Input Voltage		
	100 [Vac]	230 [Vac]	277 [Vac]
0.00	0.359	0.072	0.056
5.00	0.991	0.865	0.774
10.00	0.997	0.945	0.901
15.00	0.999	0.966	0.938
20.00	0.999	0.975	0.955
25.00	0.999	0.981	0.965

4. Leakage Current

Test Circuitry : See table

Test Equipment: Simpson 228

Value

Standard	Testing Circuitry	Measuring Method	Leakage Current [mA]			Note
			Input Voltage			
			100 [Vac]	230 [Vac]	277 [Vac]	
IEC62368-1	Figure B-1	Both phases	0.25	0.60	0.74	Operation
		One of phases	0.44	1.20	1.45	Stand by
	Figure B-2	Both phases	0.25	0.60	0.74	Operation
		One of phases	0.44	1.20	1.45	Stand by

5. Inrush Current

Test Circuitry : Figure A

— C1: Input Voltage (200V/div)
— C4: Input Current (20A/div)

Waveform

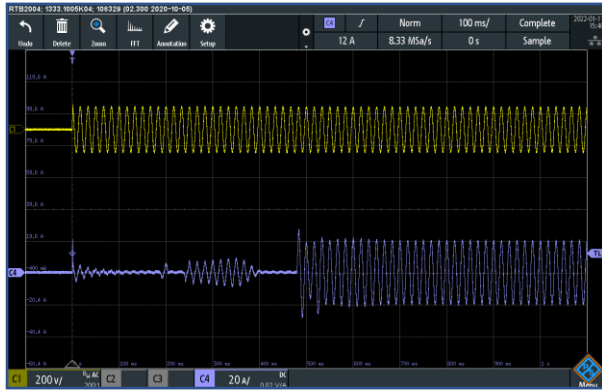

Input Voltage : 100 [Vac]
(100ms/div)

- ① Primary Inrush Current : 11.7 [A]
- ② Secondary Inrush Current : 28.3 [A]

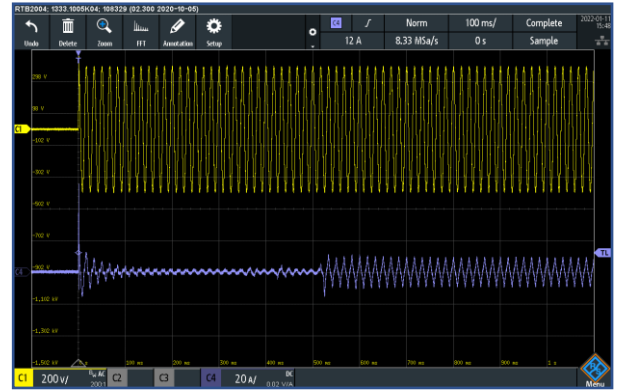

Input Voltage : 277 [Vac]
(100ms/div)

- ① Primary Inrush Current : 39.3 [A]
- ② Secondary Inrush Current : 14.8 [A]

Remark:

A surge current flown into Line-to-Line capacitor (③) would be excluded as primary inrush current (①).

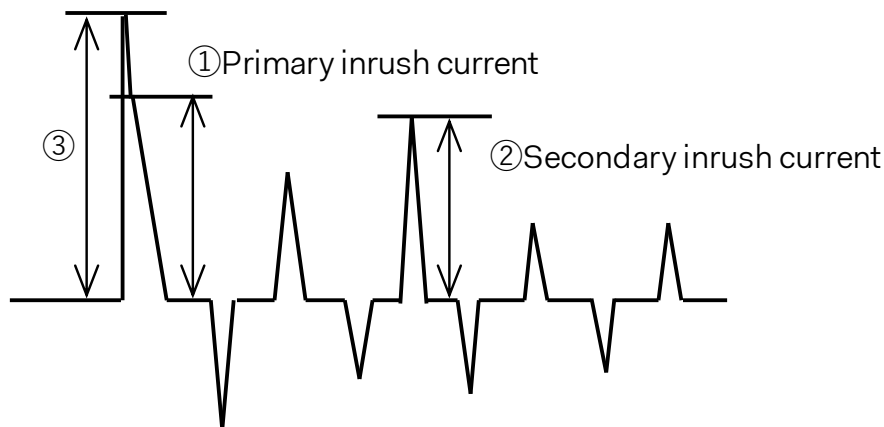

6. Line Regulation

Test Circuitry : Figure A

Change input voltage from 85 to 277 [Vac]

Graph

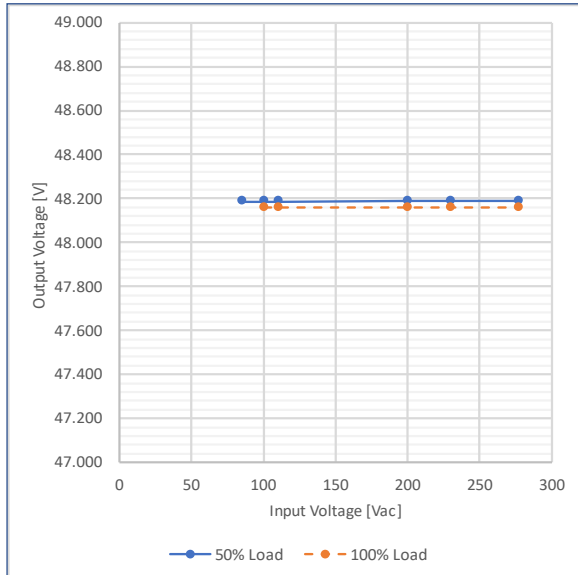

Value

Input Voltage [Vac]	Output Voltage [V]	
	Load Factor	
	50% Load	100% Load
85.00	48.187	-
100.00	48.187	48.159
110.00	48.187	48.159
200.00	48.188	48.159
230.00	48.188	48.159
277.00	48.188	48.159

7. Load Regulation

Test Circuitry : Figure A

Change Load Current from 0 to 25.0 [A]

Graph

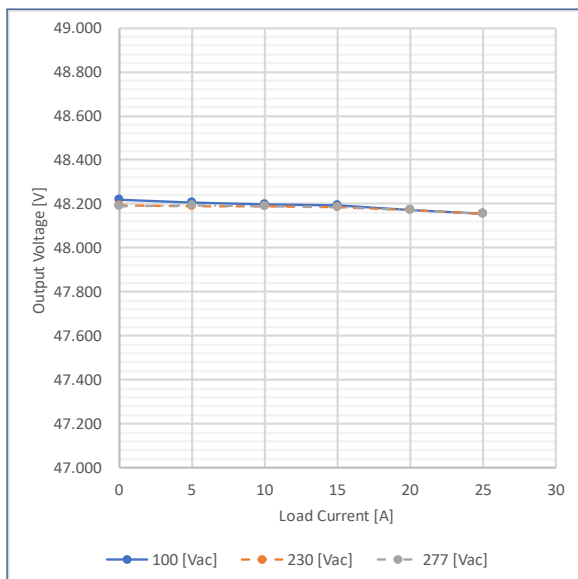

Value

Load Current [A]	Output Voltage [V]		
	Input Voltage		
	100 [Vac]	230 [Vac]	277 [Vac]
0.00	48.220	48.195	48.189
5.00	48.205	48.191	48.193
10.00	48.199	48.191	48.188
15.00	48.193	48.184	48.183
20.00	48.174	48.171	48.172
25.00	48.155	48.157	48.154

8. Ripple Noise

Test Circuitry : Figure C

— C2: Output voltage
 BW: 20MHz

Waveform



(5μs/div)
 (20mV/div)



(200ms/div)
 (50mV/div)

9. Dynamic Load Response

Test Circuitry : Figure A
 Load Current 2.5 [A] <-> 22.5 [A]

— C2: Output voltage (100mV/div)
 — C4: Output current (10A/div)

Waveform



(20ms/div)

Load changes from 10% to 90% of rated current.

10. Rise Time Characteristics by AC ON

Test Circuitry : Figure A

— C1: Input voltage (200V/div)
— C2: Output voltage (20V/div)

Waveform

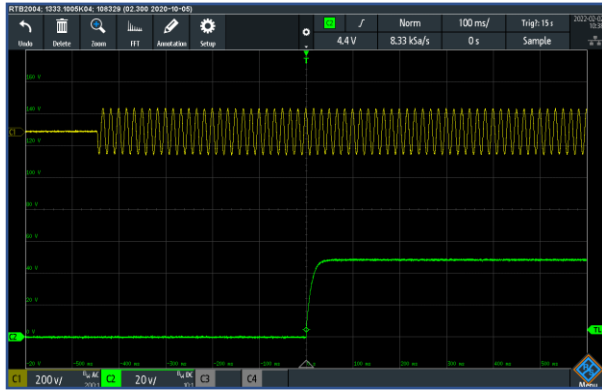

Input Voltage 100 [Vac]
 Load Current 25.0 [A]
 (100ms/div)

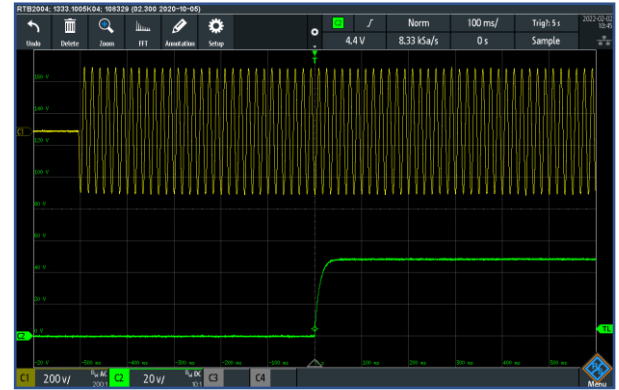

Input Voltage 277 [Vac]
 Load Current 25.0 [A]
 (100ms/div)

11. Rise Time Characteristics with RC Signal

Test Circuitry : Figure D

— C1: Input voltage (500V/div)
— C2: Output voltage (20V/div)
— C3: RC signal (10V/div)

Waveform



Input Voltage 100 [Vac]
 Load Current 25.0 [A]
 (100ms/div)

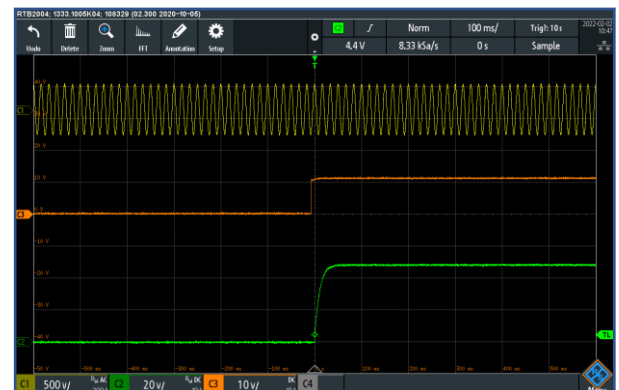

Input Voltage 277 [Vac]
 Load Current 25.0 [A]
 (100ms/div)

12. Fall Time / Hold-up Time

Test Circuitry : Figure A

— C1: Input voltage (200V/div)
 — C2: Output voltage (20V/div)

Waveform

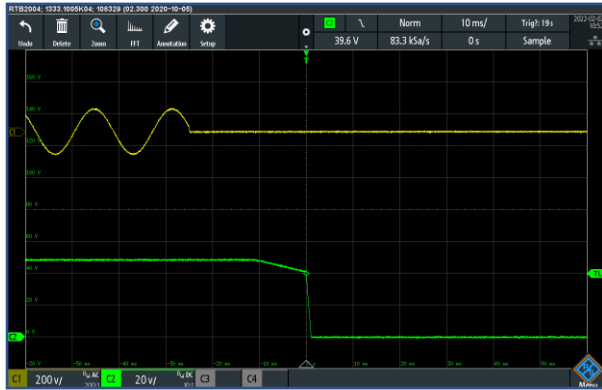

Input Voltage 100 [Vac]
 Load Current 25.0 [A]
 (10ms/div)

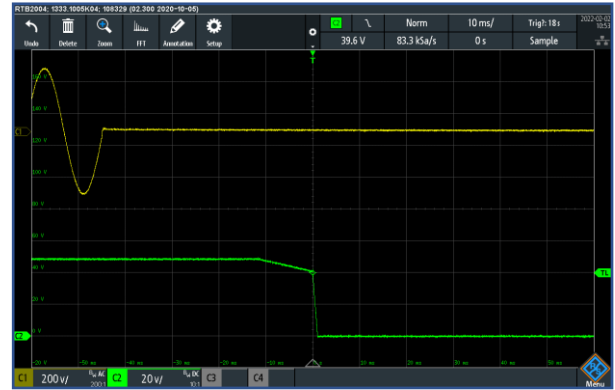

Input Voltage 277 [Vac]
 Load Current 25.0 [A]
 (10ms/div)

Graph

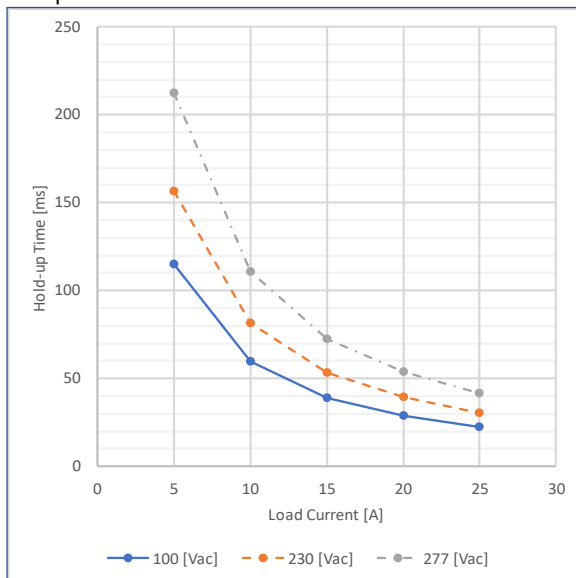

Value

Load Current [A]	Hold-up Time [ms]		
	Input Voltage		
	100 [Vac]	230 [Vac]	277 [Vac]
0.00	-	-	-
5.00	115.0	156.5	212.5
10.00	59.4	81.5	110.5
15.00	39.0	53.4	72.5
20.00	28.7	39.4	53.6
25.00	22.2	30.6	41.8

13. Over Current Protection

Test Circuitry : Figure A

Graph

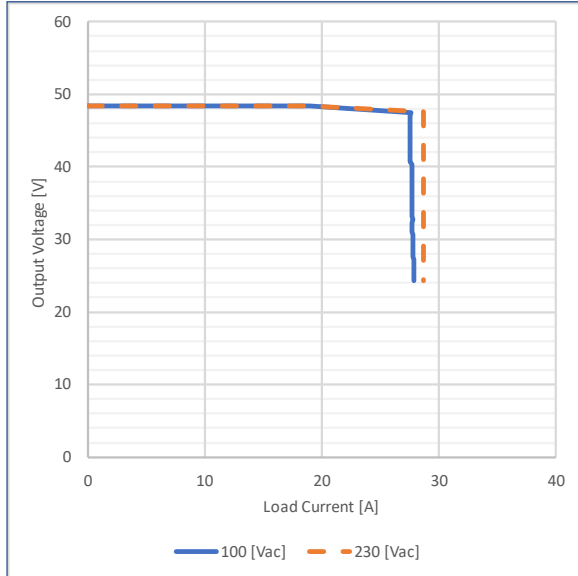

Value

Output Voltage [V]	Load Current [A]	
	Input Voltage	
	100 [Vac]	230 [Vac]
48.00	27.592	28.664
45.60	27.530	28.663
43.20	27.536	28.662
38.40	27.658	28.662
33.60	27.656	28.668
28.80	27.782	28.667

Waveform

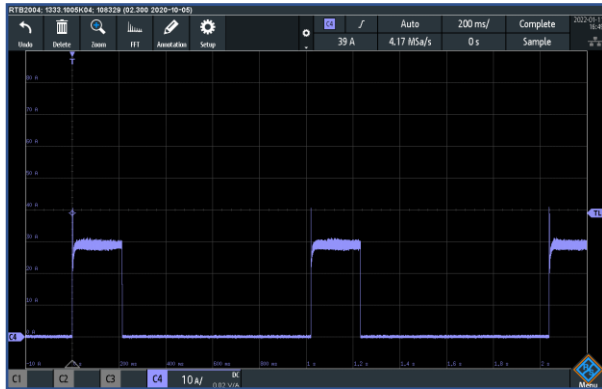

— C4: Output Current (10A/div)

Intermittent operation occurs when the output voltage is from 24.0V to 0V.

Input Voltage 230 [Vac]
Output Short
(200ms/div)

14. Minimum Input Voltage for Regulated Output Voltage

Test Circuitry : Figure A

Graph

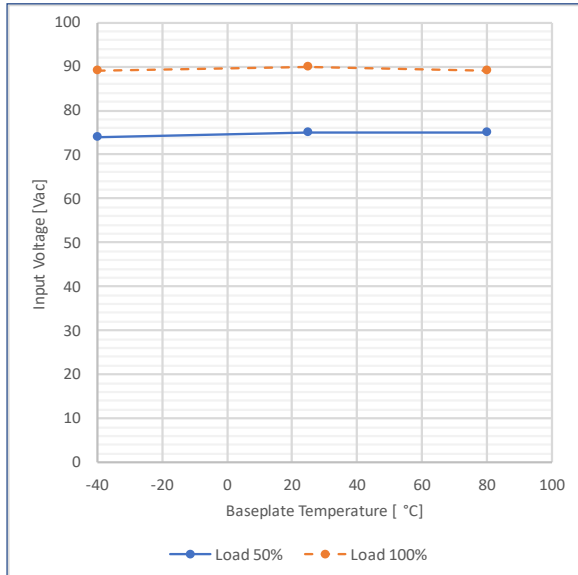

Value

Baseplate Temperature [°C]	Input Voltage [Vac]	
	Load Current	
	Load 50%	Load 100%
-40	74	89
25	75	90
80	75	89

The low input voltage protection is activated on the condition of load 100%.

15. Over Voltage Protection

Test Circuitry : Figure A

Graph

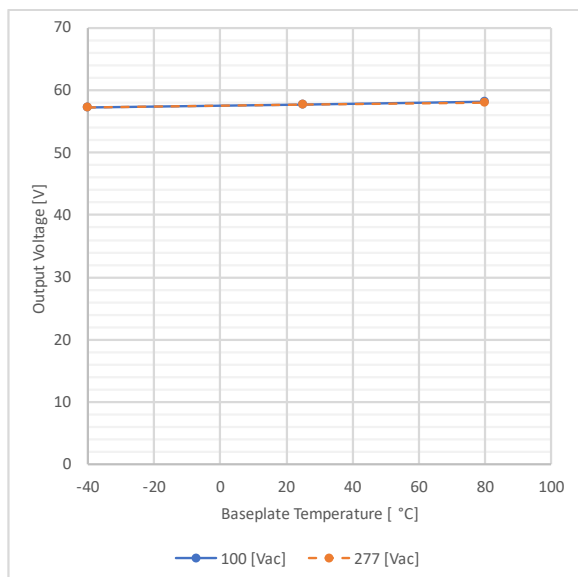

Value

Baseplate Temperature [°C]	Output Voltage [V]	
	Input Voltage	
	100 [Vac]	277 [Vac]
-40	57.250	57.250
25	57.780	57.660
80	58.190	58.070

16. Conducted Emission

Input Voltage : 115Vac / 230Vac 50Hz Load : 100 %

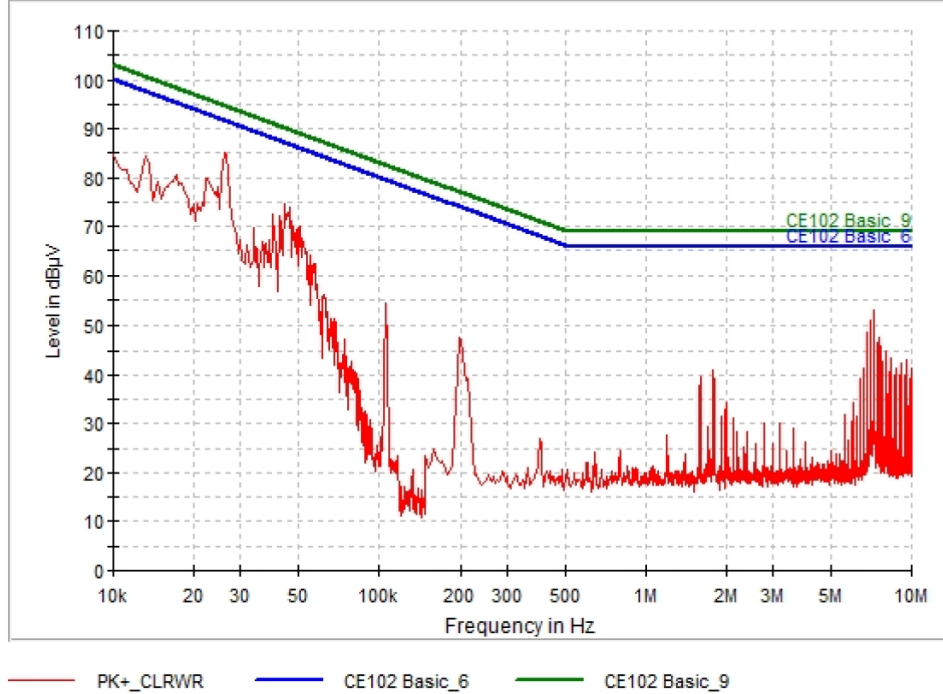

Fig. 16.1 MIL-STD-461F CE102 Result OFD1200A48, 115V, N

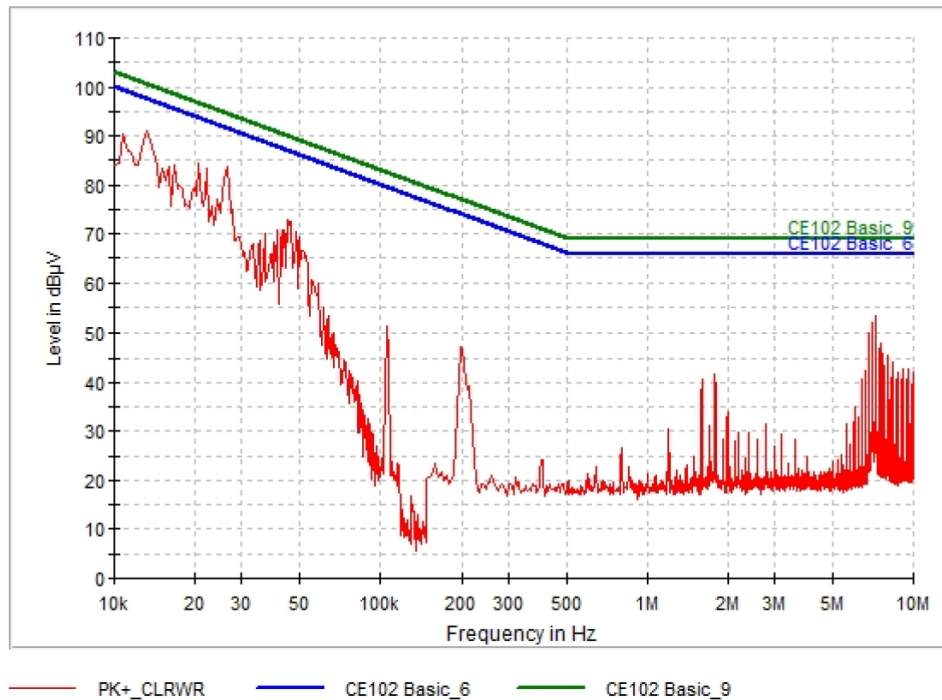

Fig. 16.2 MIL-STD-461F CE102 Result OFD1200A48, 115V, L1

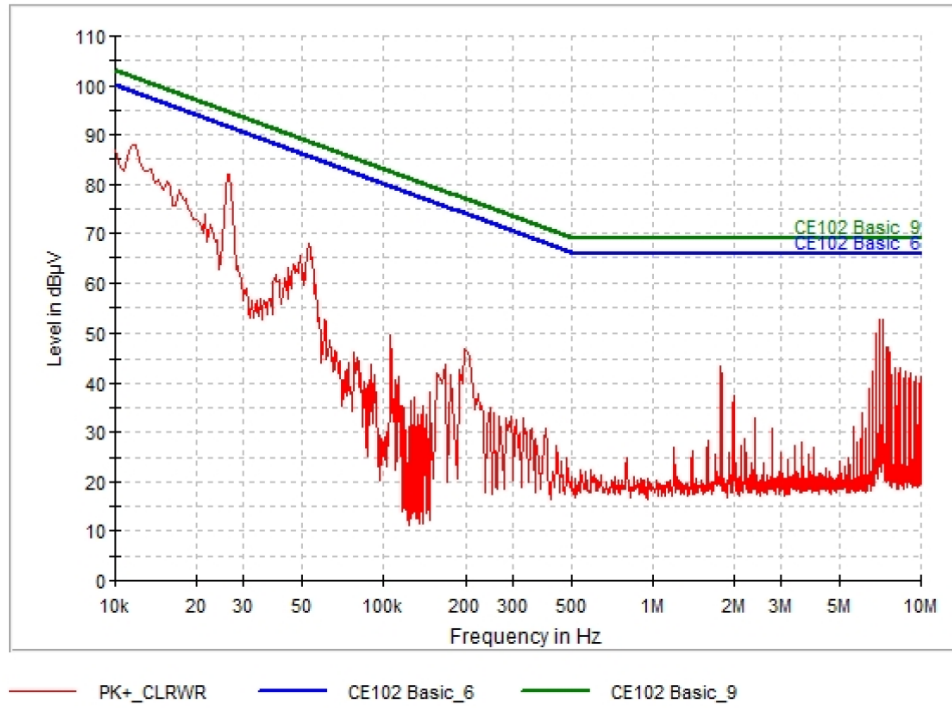

Fig. 16.3 MIL-STD-461F CE102 Result OFD1200A48, 230V, N

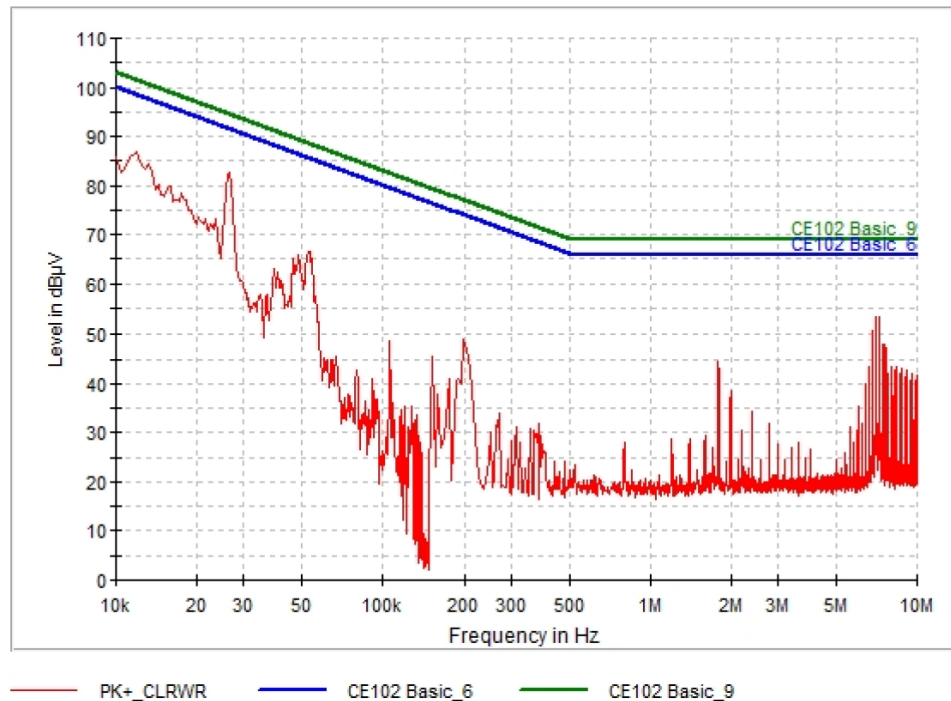

Fig. 16.4 MIL-STD-461F CE102 Result OFD1200A48, 230V, L1

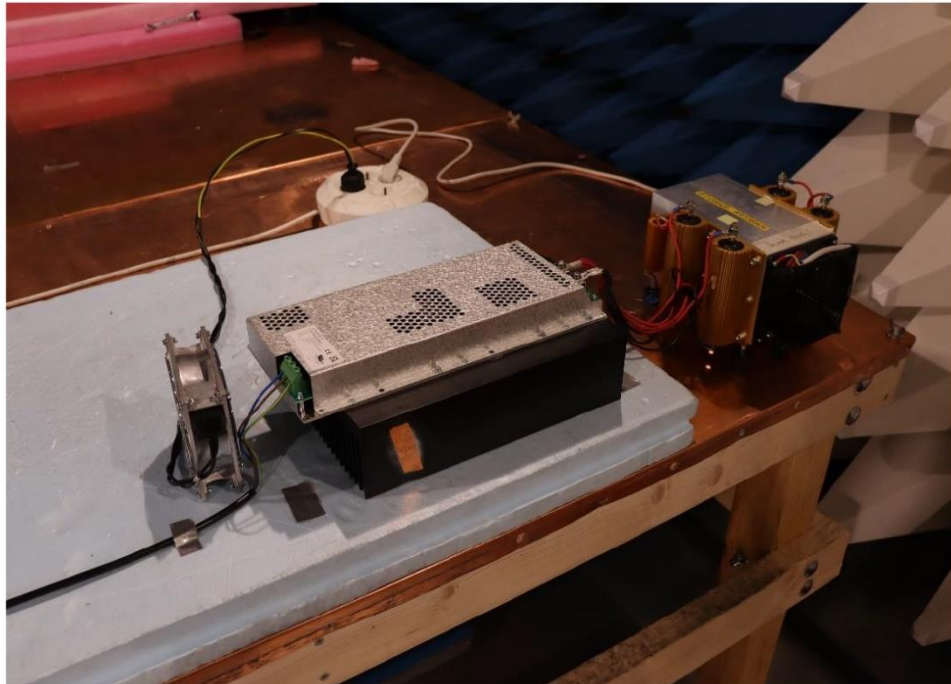

Fig. 16.5 MIL-STD-461F CE102 test environment

17. Figure of Test Circuitry

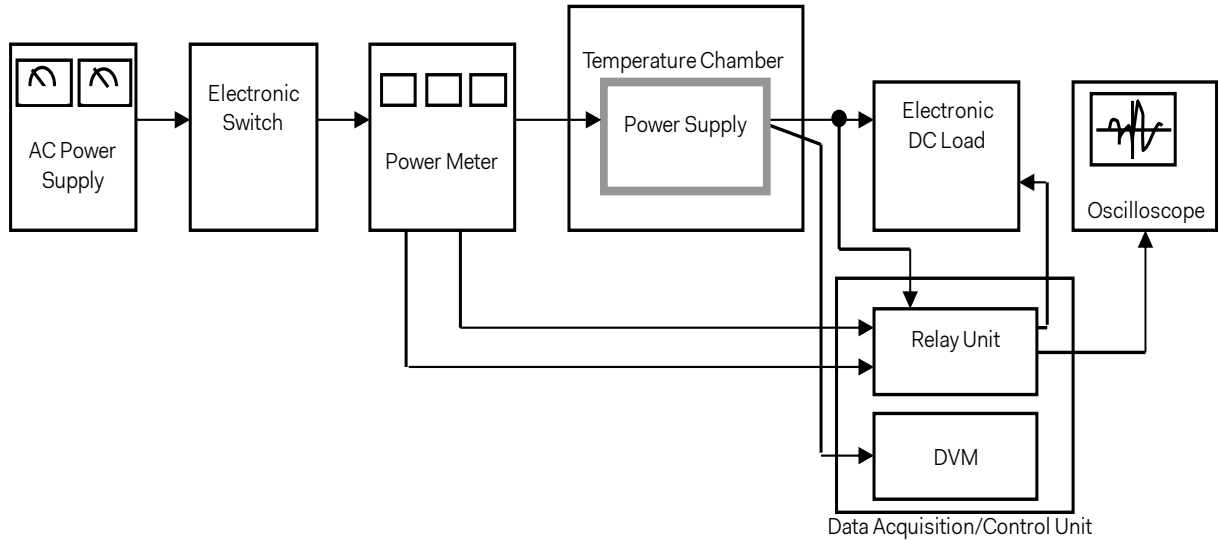

Figure A Test circuitry for general performance measurement

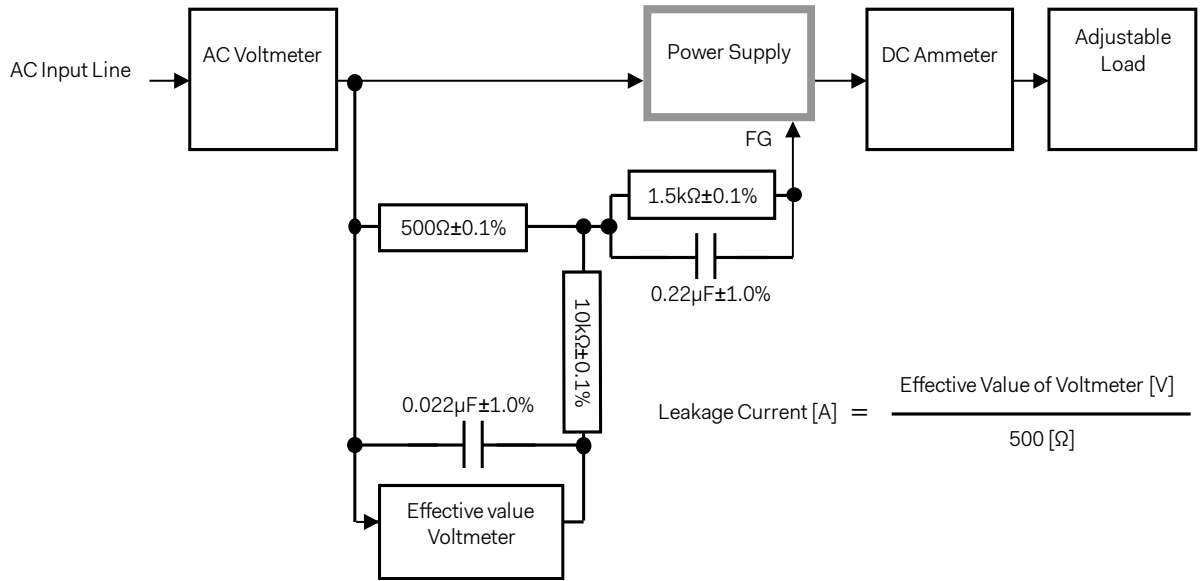

Figure B-1 Leakage current measurement (IEC62368-1, refer to IEC60990 Fig.4)

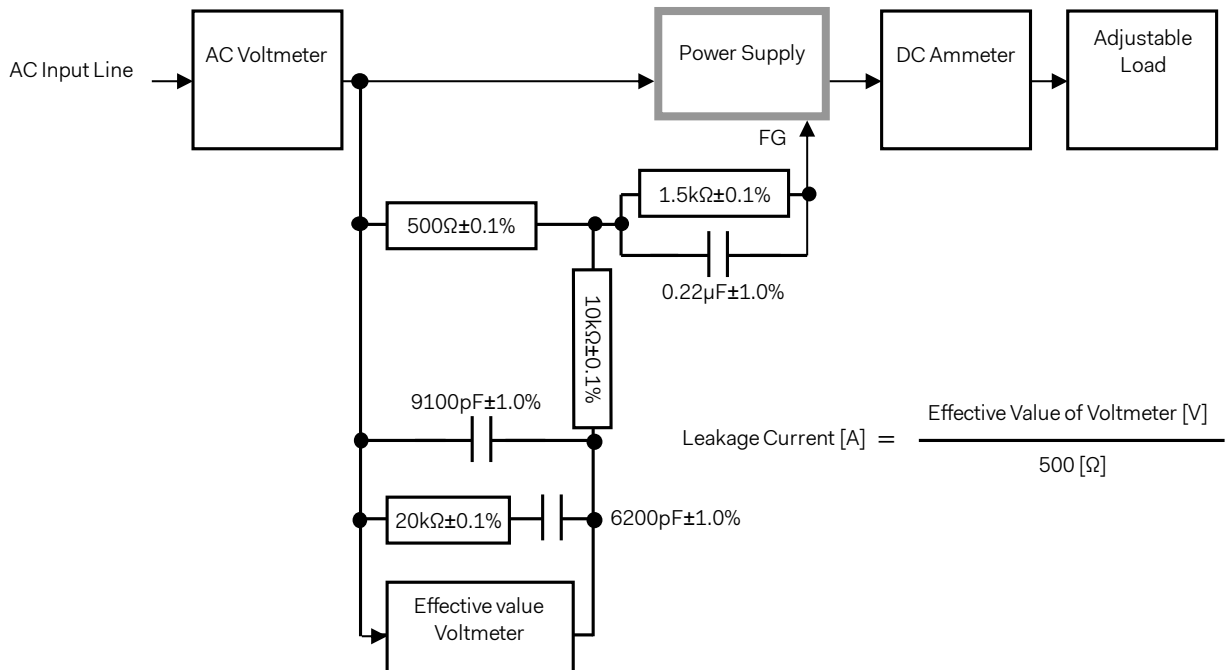

Figure B-2 Leakage current measurement (IEC62368-1, refer to IEC60990 Fig.5)

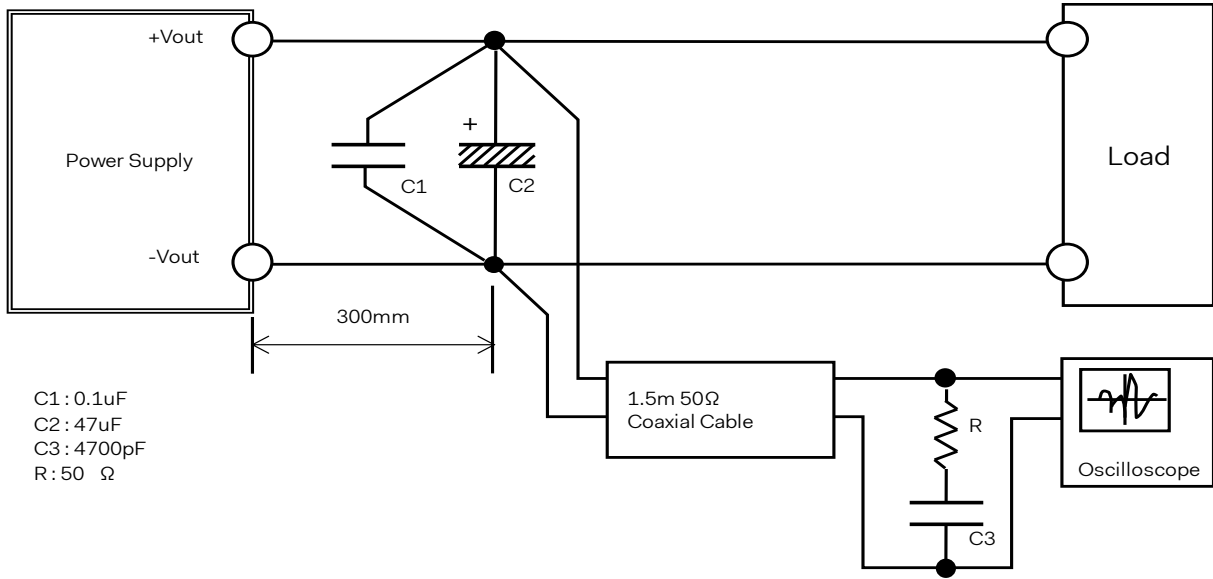

Figure C Ripple voltage measurement (JEITA RC-9131D)

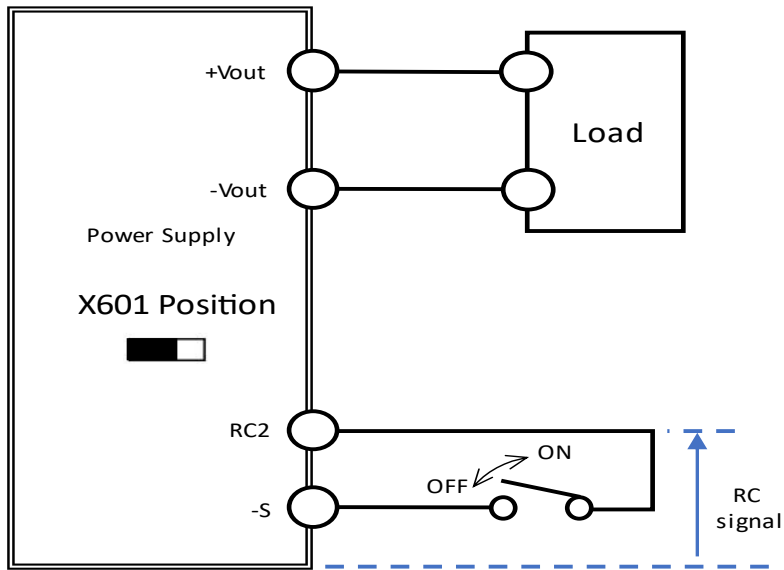

Figure D Turn on by RC measurement