

EVALUATION DATA

MODEL NAME : OFD1200A12

Tested by : *Shintaro Oki*
Shintaro Oki

Approved by : *Tomas Isaksson*
Tomas Isaksson

P R

B X

POWERBOX
A Cosel Group Company

Table of Contents

1. Input Current (by Load Current)	3
2. Efficiency (by Load Current).....	3
3. Power Factor (by Load Current)	4
4. Leakage Current	4
5. Inrush Current	5
6. Line Regulation	6
7. Load Regulation	6
8. Ripple Noise.....	7
9. Dynamic Load Response	7
10. Rise Time Characteristics by AC ON	8
11. Rise Time Characteristics with RC Signal.....	8
12. Fall Time / Hold-up Time	9
13. Over Current Protection	10
14. Minimum Input Voltage for Regulated Output Voltage	11
15. Over Voltage Protection	11
16. Conducted Emission	12
17. Figure of Test Circuitry	15

Remark:

Unless specified the test condition shall be

Input voltage / Frequency: 230 [Vac] / 50 [Hz]

Load current: 84.0 [A]

Baseplate temperature: 25 [°C]

1. Input Current (by Load Current)

Test Circuitry : Figure A

Graph

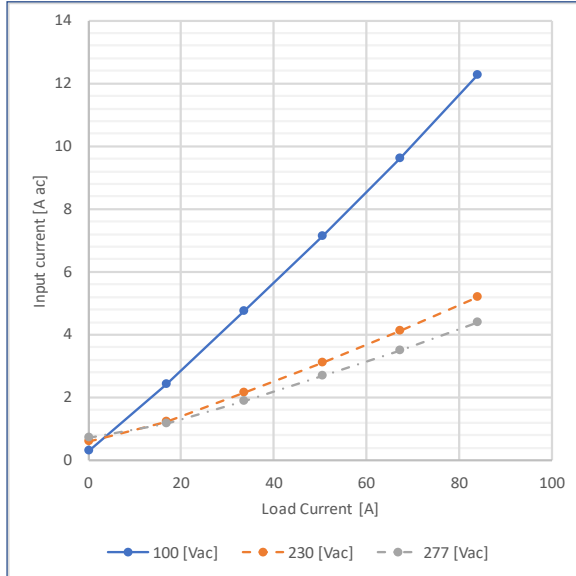

Value

Load Current [A]	Input Current [Aac]		
	Input Voltage		
	100 [Vac]	230 [Vac]	277 [Vac]
0.00	0.288	0.610	0.719
16.80	2.423	1.230	1.175
33.60	4.738	2.145	1.888
50.40	7.131	3.118	2.681
67.20	9.601	4.126	3.502
84.00	12.257	5.198	4.379

2. Efficiency (by Load Current)

Test Circuitry : Figure A

Graph

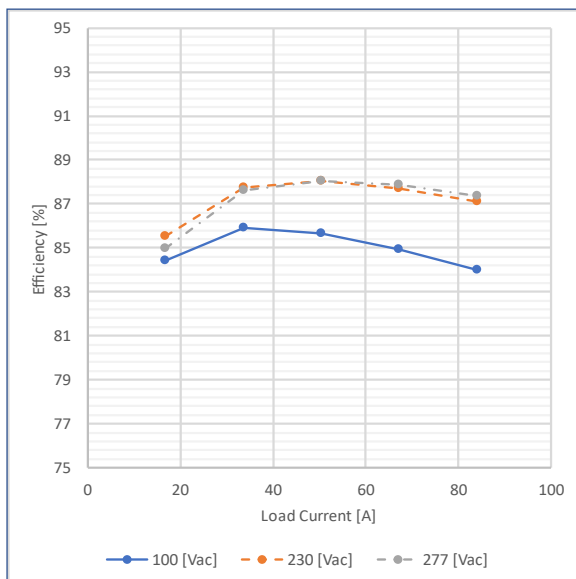

Value

Load Current [A]	Efficiency [%]		
	Input Voltage		
	100 [Vac]	230 [Vac]	277 [Vac]
0.00	-	-	-
16.80	84.410	85.544	84.990
33.60	85.893	87.754	87.615
50.40	85.670	88.043	88.049
67.20	84.944	87.692	87.875
84.00	84.001	87.091	87.342

3. Power Factor (by Load Current)

Test Circuitry : Figure A

Graph

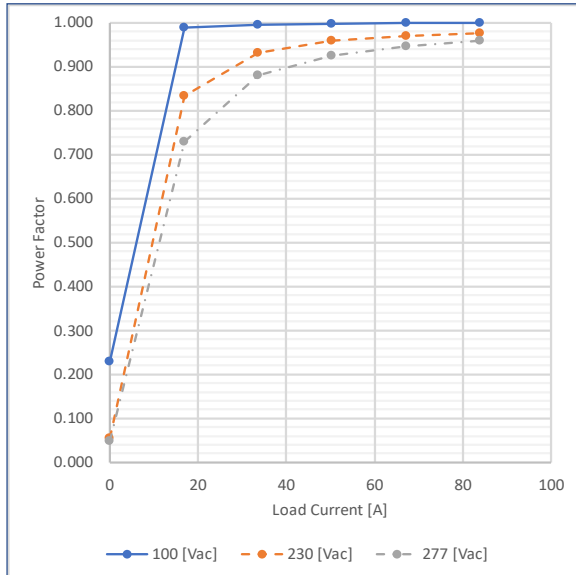

Value

Load Current [A]	Power Factor		
	Input Voltage		
	100 [Vac]	230 [Vac]	277 [Vac]
0.00	0.230	0.056	0.048
16.80	0.989	0.834	0.730
33.60	0.996	0.932	0.881
50.40	0.998	0.959	0.926
67.20	0.999	0.970	0.947
84.00	0.999	0.977	0.960

4. Leakage Current

Test Circuitry : See table

Test Equipment: Simpson 228

Value

Standard	Testing Circuitry	Measuring Method	Leakage Current [mA]			Note
			Input Voltage			
			100 [Vac]	230 [Vac]	277 [Vac]	
IEC62368-1	Figure B-1	Both phases	0.25	0.60	0.74	Operation
		One of phases	0.44	1.20	1.45	Stand by
	Figure B-2	Both phases	0.25	0.60	0.74	Operation
		One of phases	0.44	1.20	1.45	Stand by

5. Inrush Current

Test Circuitry : Figure A

— C1: Input Voltage (200V/div)
— C4: Input Current (20A/div)

Waveform

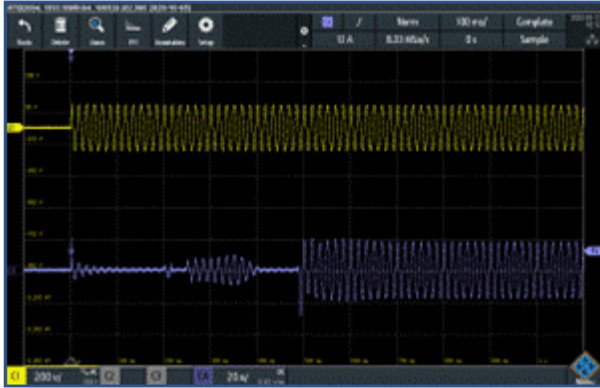

Input Voltage : 100 [Vac]
(100ms/div)

- ① Primary Inrush Current : 12.5 [A]
- ② Secondary Inrush Current : 28.3 [A]



Input Voltage : 277 [Vac]
(100ms/div)

- ① Primary Inrush Current : 37.1 [A]
- ② Secondary Inrush Current : 14.0 [A]

Remark:

A surge current flown into Line-to-Line capacitor (③) would be excluded as primary inrush current (①).

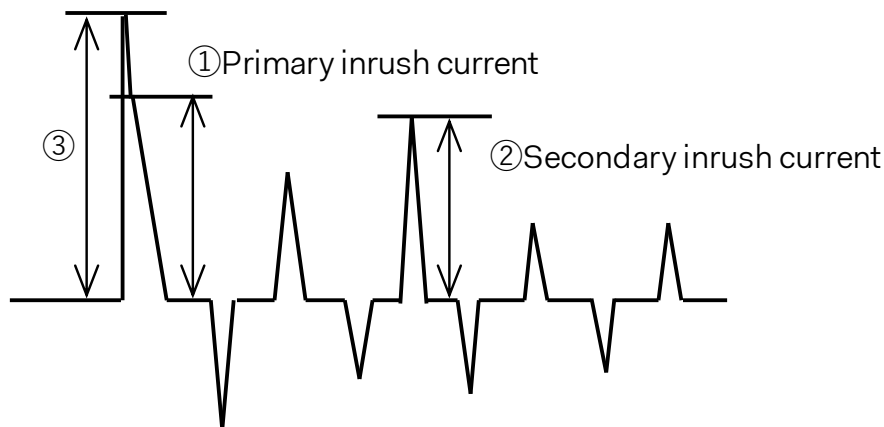

6. Line Regulation

Test Circuitry : Figure A

Change input voltage from 85 to 277 [Vac]

Graph

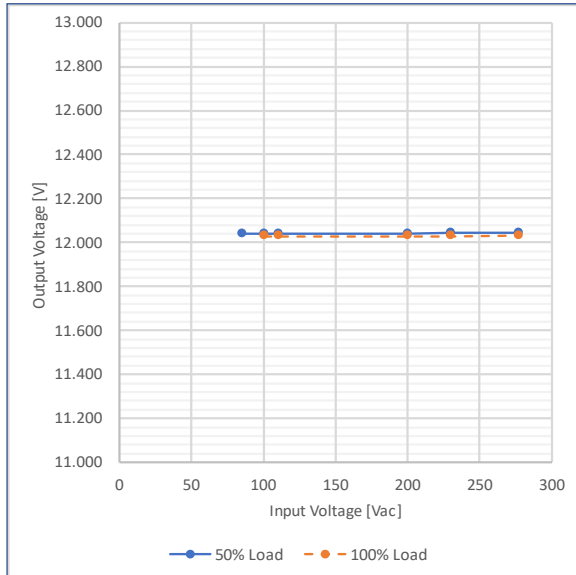

Value

Input Voltage [Vac]	Output Voltage [V]	
	Load Factor	
	50% Load	100% Load
85.00	12.041	-
100.00	12.041	12.031
110.00	12.041	12.031
200.00	12.042	12.031
230.00	12.043	12.031
277.00	12.043	12.033

7. Load Regulation

Test Circuitry : Figure A

Change Load Current from 0 to 84.0 [A]

Graph

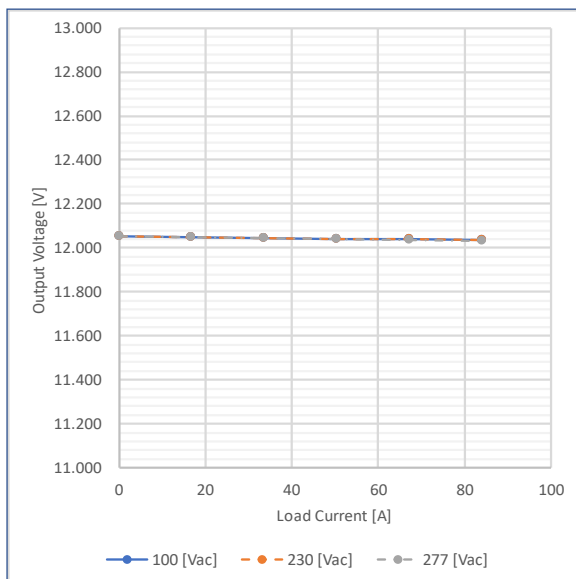

Value

Load Current [A]	Output Voltage [V]		
	Input Voltage		
	100 [Vac]	230 [Vac]	277 [Vac]
0.00	12.052	12.052	12.051
16.80	12.048	12.049	12.050
33.60	12.045	12.045	12.045
50.40	12.042	12.042	12.041
67.20	12.039	12.039	12.037
84.00	12.036	12.034	12.033

8. Ripple Noise

Test Circuitry : Figure C

— C2: Output voltage (20mV/div)
 BW: 20MHz

Waveform

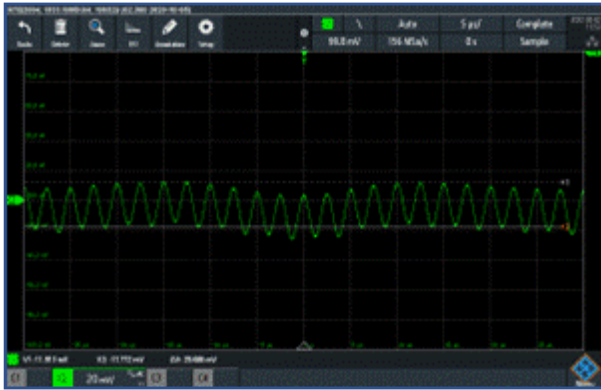

(5µs/div)



(200ms/div)

9. Dynamic Load Response

Test Circuitry : Figure A
 Load Current 8.4 [A] <-> 75.6 [A]

— C2: Output voltage (50mV/div)
 — C4: Output current (50A/div)

Waveform



(50ms/div)

Load changes from 10% to 90% of rated current.

10. Rise Time Characteristics by AC ON

Test Circuitry : Figure A

— C1: Input voltage (200V/div)
— C2: Output voltage (5V/div)

Waveform

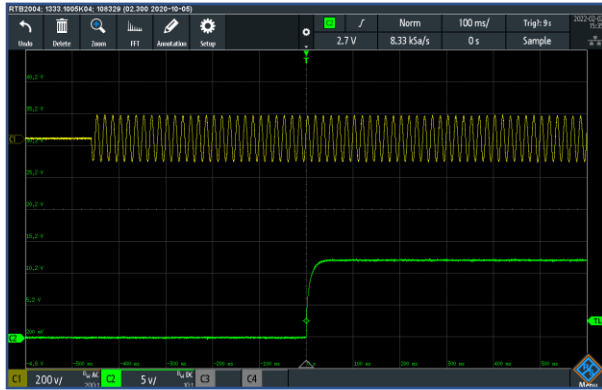

Input Voltage 100 [Vac]
Load Current 84.0 [A]
(100ms/div)

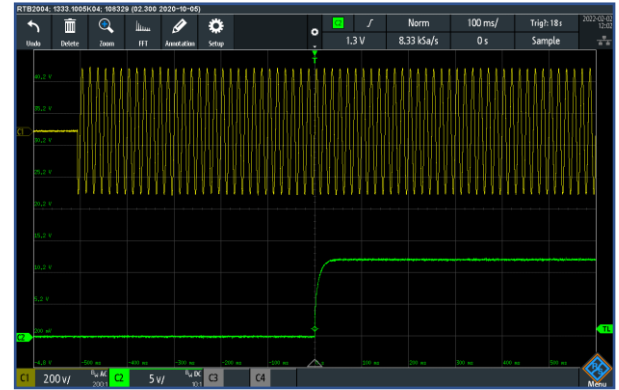

Input Voltage 277 [Vac]
Load Current 84.0 [A]
(100ms/div)

11. Rise Time Characteristics with RC Signal

Test Circuitry : Figure D

— C1: Input voltage (500V/div)
— C2: Output voltage (5V/div)
— C3: RC signal (10V/div)

Waveform



Input Voltage 100 [Vac]
Load Current 84.0 [A]
(100ms/div)

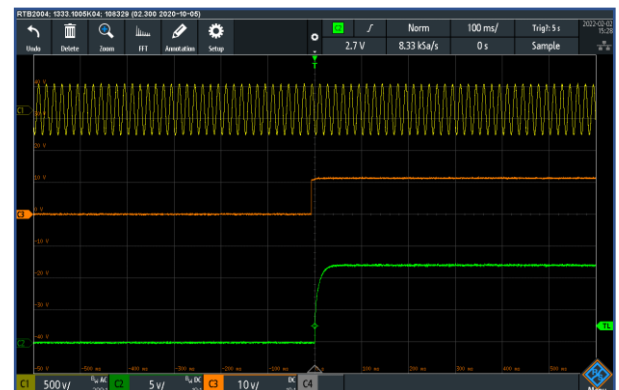

Input Voltage 277 [Vac]
Load Current 84.0 [A]
(100ms/div)

12. Fall Time / Hold-up Time

Test Circuitry : Figure A

— C1: Input voltage (200V/div)
 — C2: Output voltage (5V/div)

Waveform

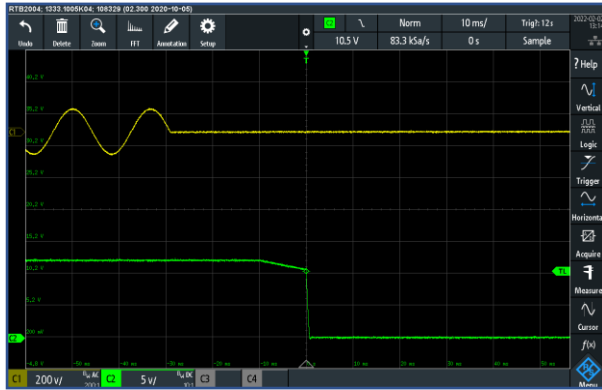

Input Voltage 100 [Vac]
 Load Current 84.0 [A]
 (10ms/div)

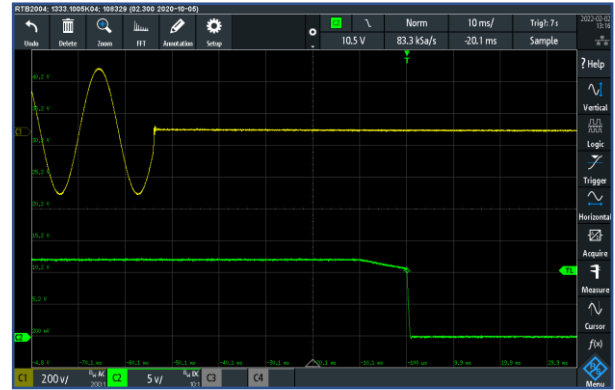

Input Voltage 277 [Vac]
 Load Current 84.0 [A]
 (10ms/div)

Graph

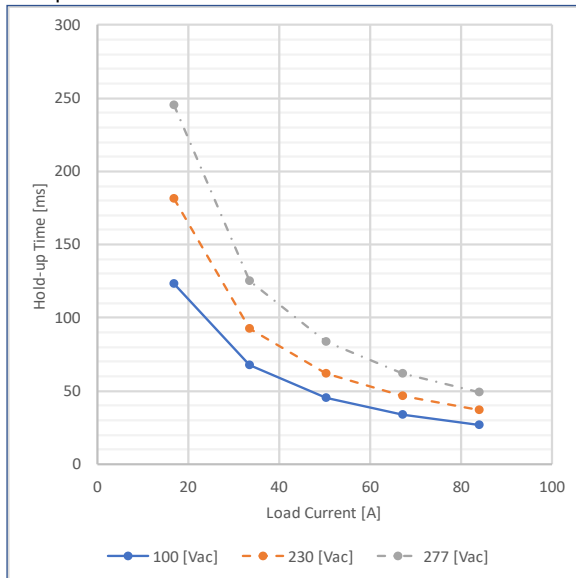

Value

Load Current [A]	Hold-up Time [ms]		
	Input Voltage		
	100 [Vac]	230 [Vac]	277 [Vac]
0.00	-	-	-
16.80	123.5	181.5	245.5
33.60	67.6	92.5	125.0
50.40	45.6	62.2	83.4
67.20	34.1	46.6	62.0
84.00	26.7	37.2	49.4

13. Over Current Protection

Test Circuitry : Figure A

Graph

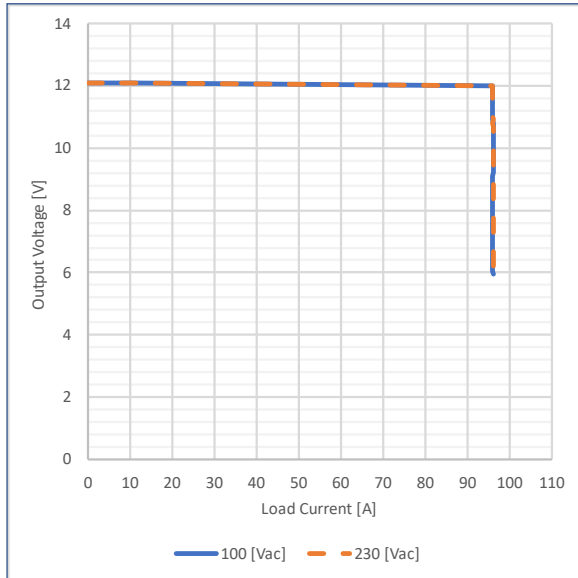

Value

Output Voltage [V]	Load Current [A]	
	Input Voltage	
	100 [Vac]	230 [Vac]
12.00	96.078	96.083
11.40	96.091	96.091
10.80	96.101	96.095
9.60	96.132	96.315
8.40	96.043	96.309
7.20	96.049	96.306

Waveform

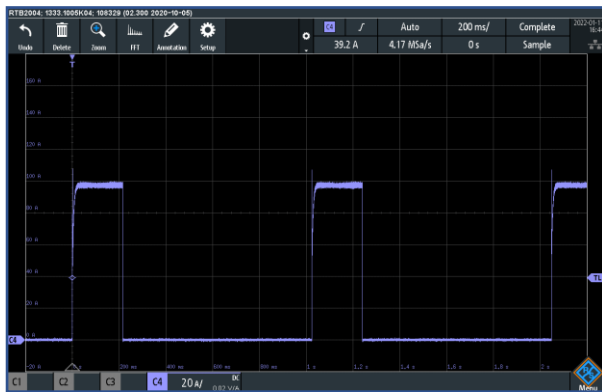

C4: Output Current (20A/div)

Intermittent operation occurs when the output voltage is from 6.0V to 0V.

Input Voltage 230 [Vac]
Output Short
(200ms/div)

14. Minimum Input Voltage for Regulated Output Voltage

Test Circuitry : Figure A

Graph

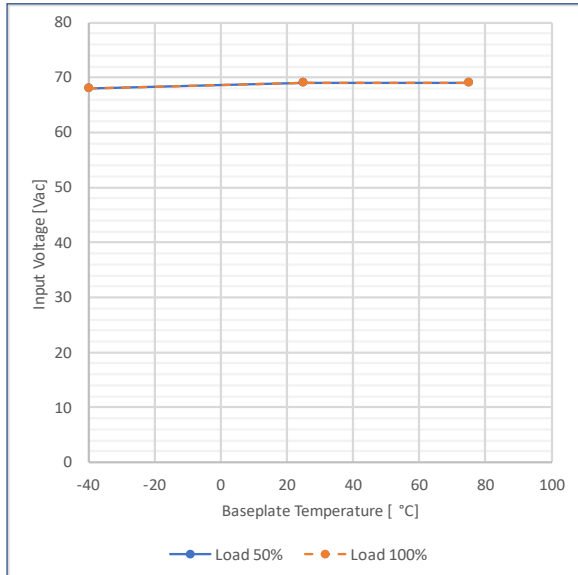

Value

Baseplate Temperature [°C]	Input Voltage [Vac]	
	Load Current	
	Load 50%	Load 100%
-40	68	68
25	69	69
75	69	69

15. Over Voltage Protection

Test Circuitry : Figure A

Graph

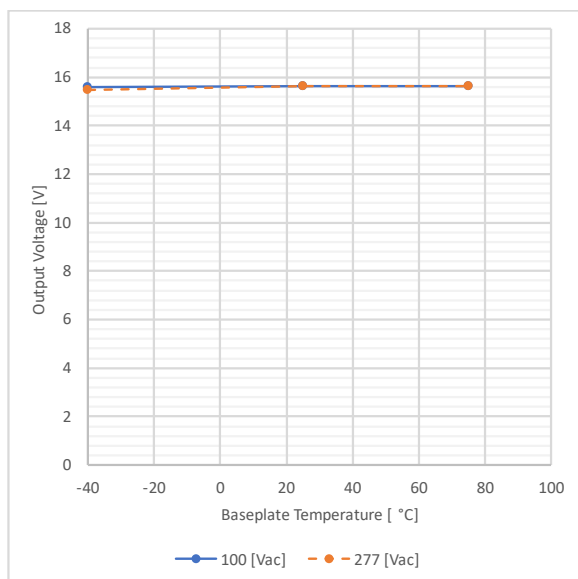

Value

Baseplate Temperature [°C]	Output Voltage [V]	
	Input Voltage	
	100 [Vac]	277 [Vac]
-40	15.580	15.460
25	15.640	15.640
75	15.640	15.640

16. Conducted Emission

Input Voltage : 115Vac / 230Vac 50Hz Load : 100 %

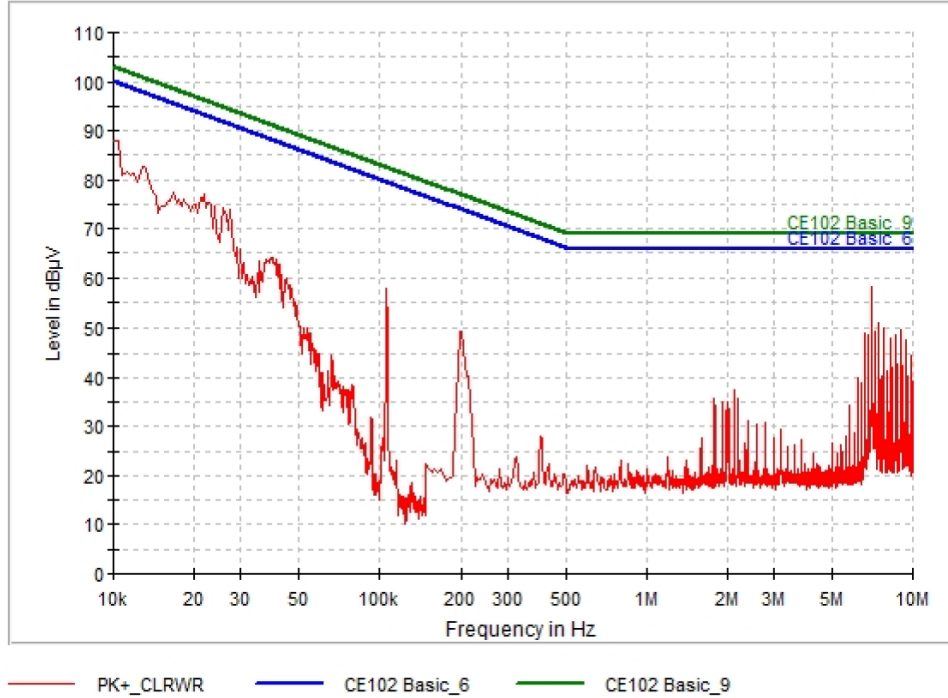

Fig. 16.1 MIL-STD-461F CE102 Result OFD1200A12, 115V, N

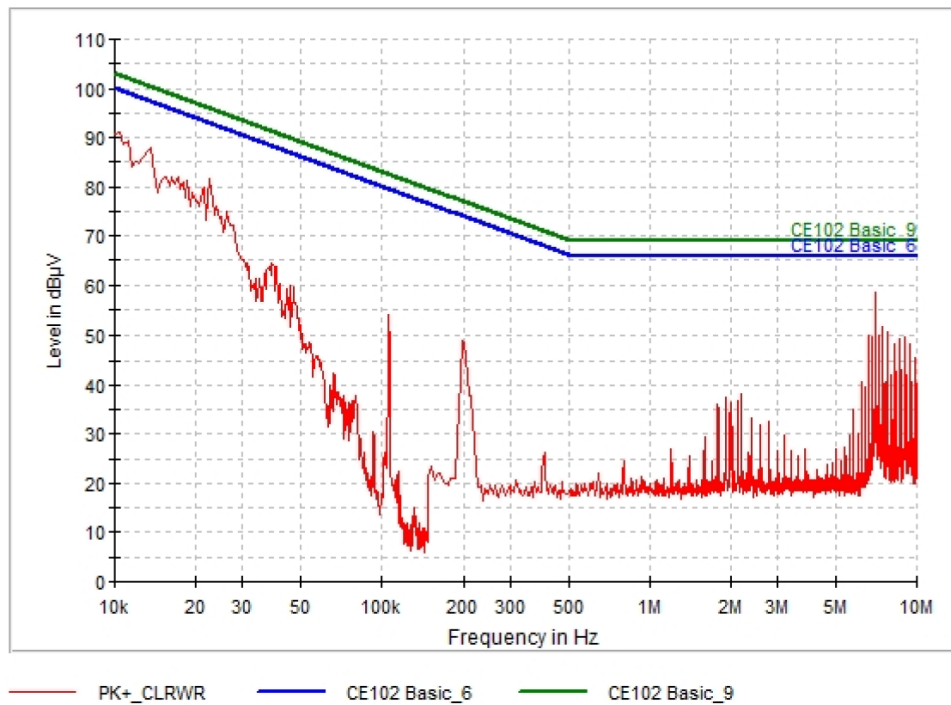
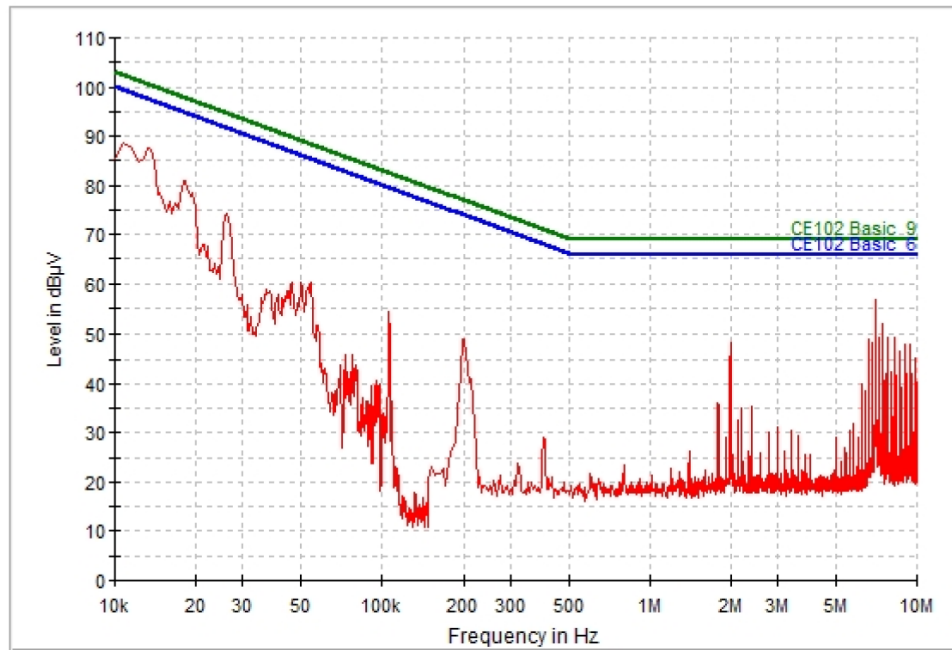
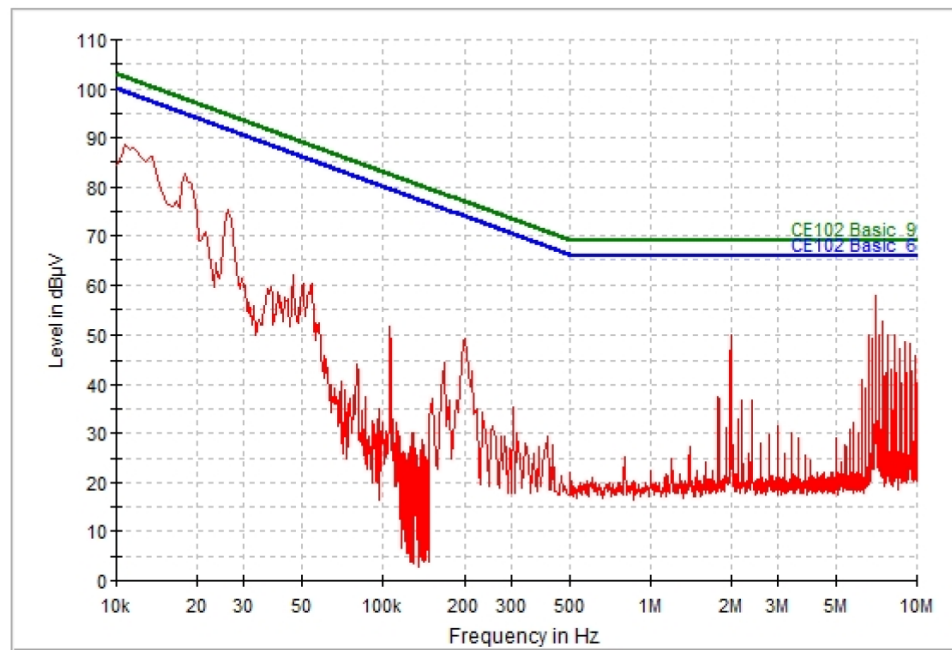

Fig. 16.2 MIL-STD-461F CE102 Result OFD1200A12, 115V, L1



PK+_CLRWR CE102 Basic_6 CE102 Basic_9

Fig. 16.3 MIL-STD-461F CE102 Result OFD1200A12, 230V, N



PK+_CLRWR CE102 Basic_6 CE102 Basic_9

Fig. 16.4 MIL-STD-461F CE102 Result OFD1200A12, 230V, L1

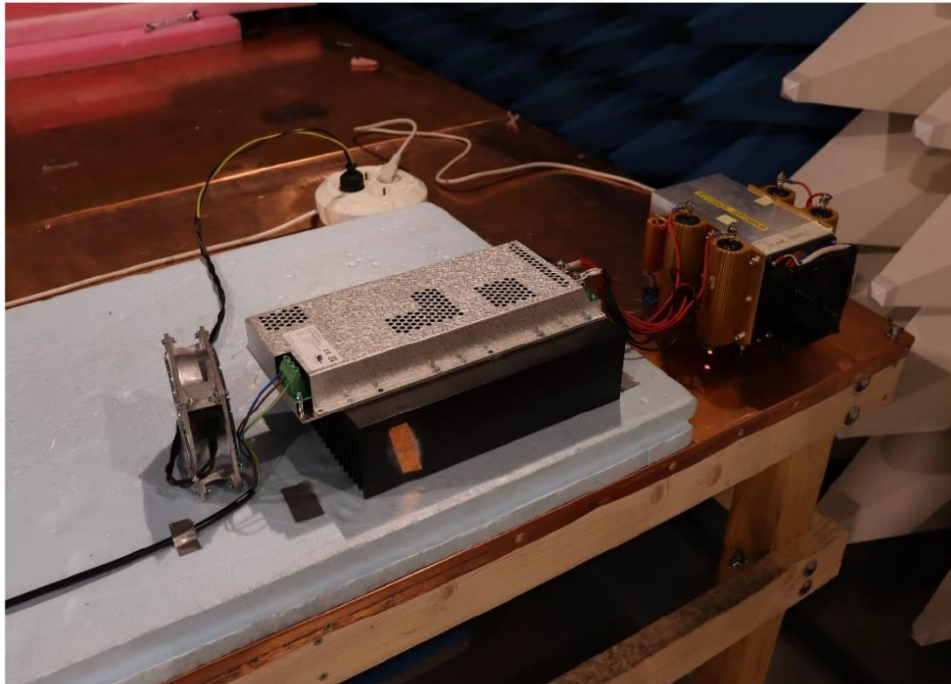

Fig. 16.5 MIL-STD-461F CE102 test environment

17. Figure of Test Circuitry

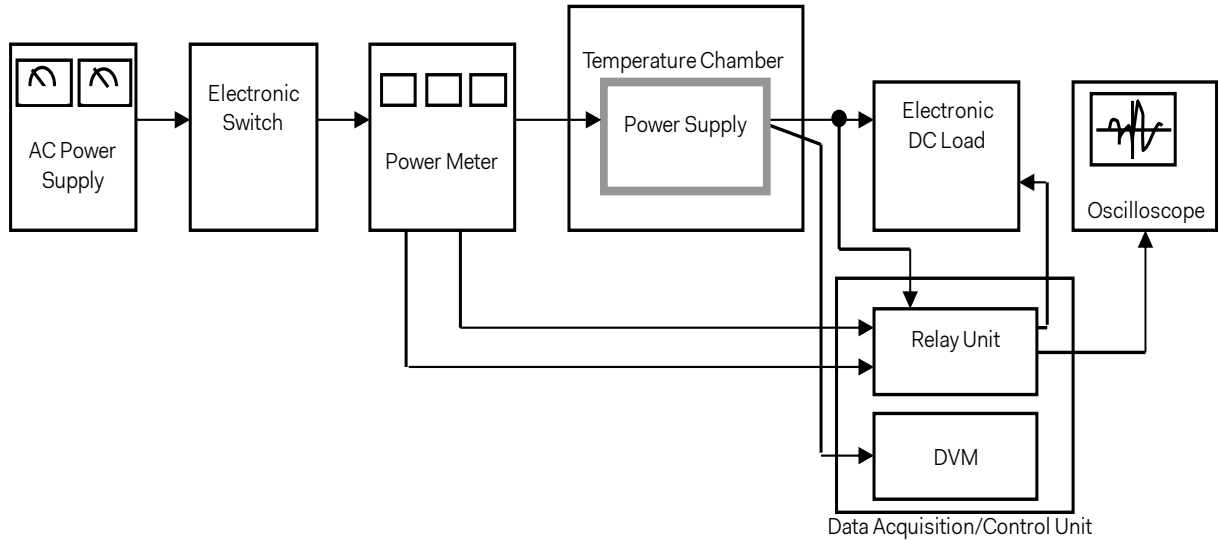

Figure A Test circuitry for general performance measurement

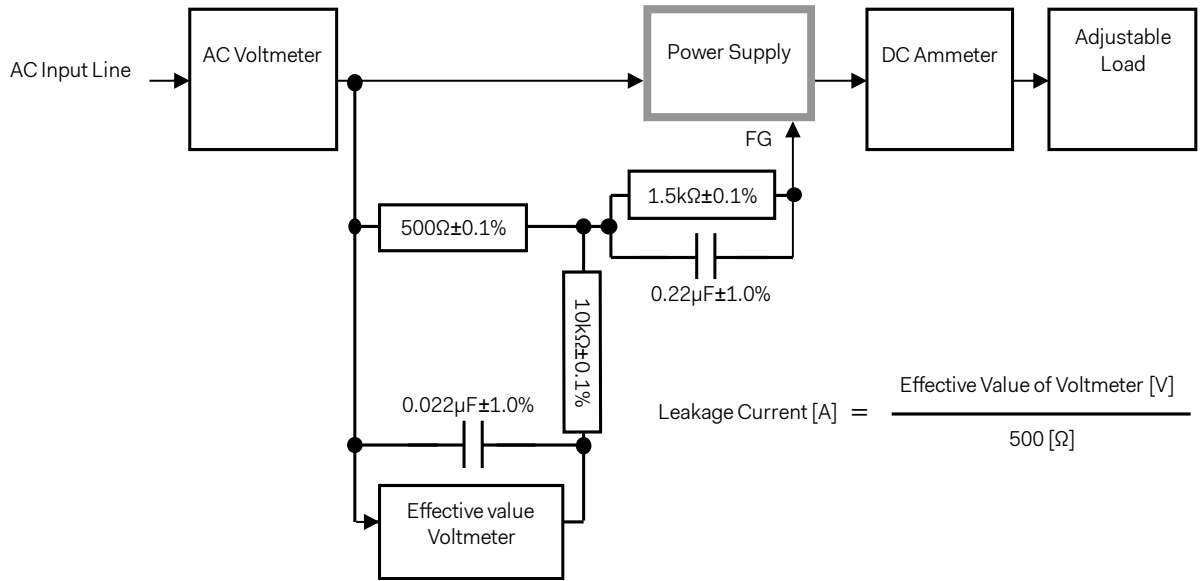

Figure B-1 Leakage current measurement (IEC62368-1, refer to IEC60990 Fig.4)

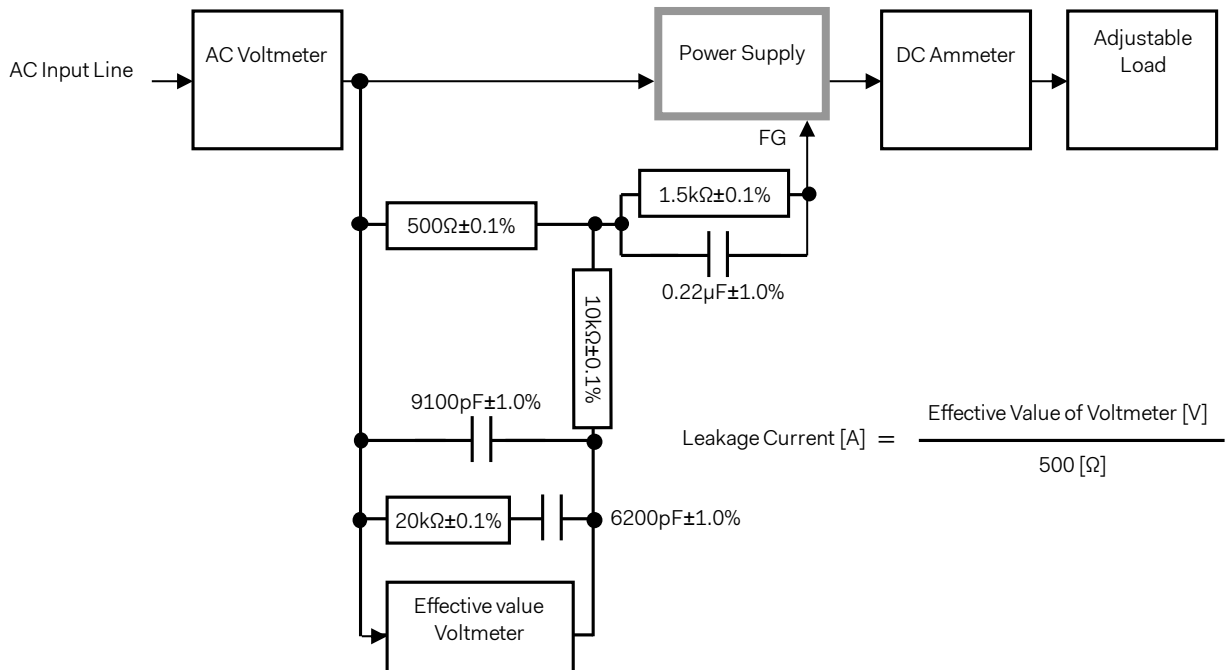

Figure B-2 Leakage current measurement (IEC62368-1, refer to IEC60990 Fig.5)

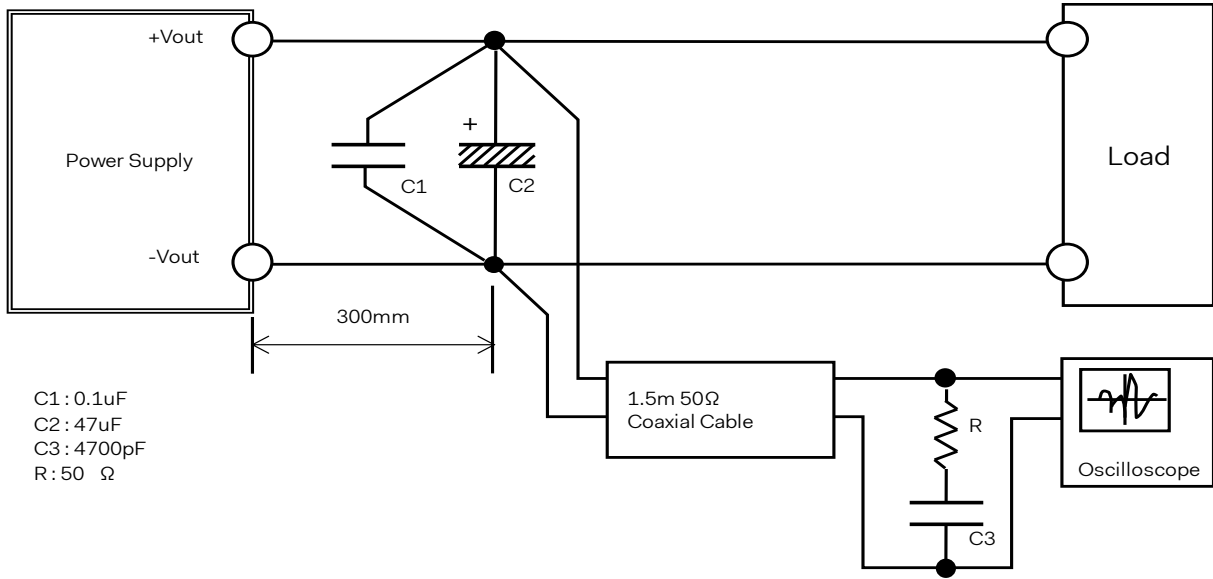

Figure C Ripple voltage measurement (JEITA RC-9131D)

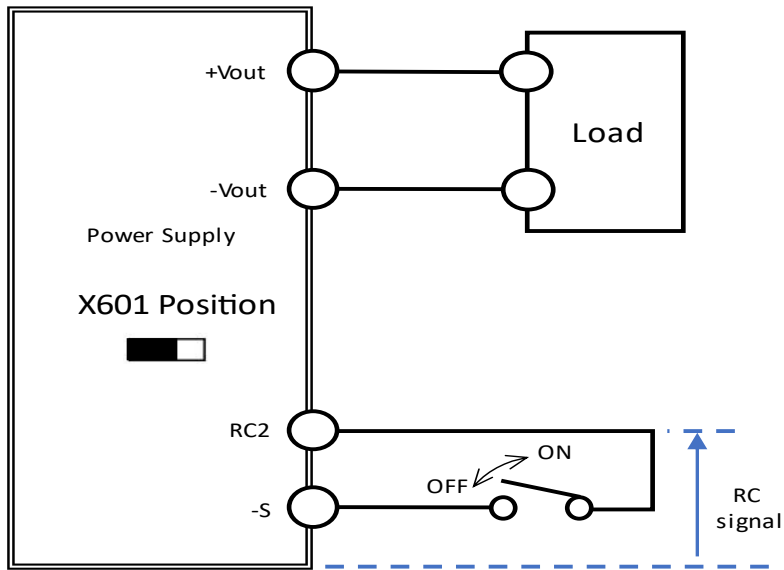

Figure D Turn on by RC measurement