

## Table of Contents

1.	Assembling and Installation Method
1.1	Mounting method
1.2	Isolation from conductive enclosure
1.3	Installation to fulfill EMC requirement
2.	Derating
2.1	Derating curve by input voltage
2.2	Temperature measuring point
3.	Wiring
3.1	Wiring input connector
3.2	Wiring output terminal
3.3	Wiring function connector
3.4	Jumper factory setting
3.5	Output ripple and ripple noise measurement
4.	Functions
4.1	Input voltage range
4.2	Inrush current limiting
4.3	Overcurrent protection
4.4	Overvoltage protection
4.5	Thermal protection
4.6	Output voltage adjustment
4.7	Remote ON/OFF
4.8	Remote sensing
4.9	Signal output (LED / DC OK / IOG)
4.10	Auxiliary Power (AUX)
5.	Series / Parallel Operation
5.1	Series operation
5.2	Parallel operation
5.3	Redundancy operation
6.	Life Expectancy and Warranty
6.1	Life Expectancy
6.2	Warranty
7.	Option and Others
7.1	Options
7.2	12V output for pulse current

Remark:

When using the product, please refer to General safety instruction power products.

[Standards and policies | Powerbox \(prbx.com\)](http://Standards and policies | Powerbox (prbx.com))

## 1. Assembling and Installation Method

### 1.1 Mounting method

OFI700A series should be mounted to heatsink or enclosure which has sufficient thermal capacity to be cooled by conduction cooling.

OFI700A has 10 of 5mm diameter mounting, to keep uniform thermal conductivity, use at least 6 mounting holes as shown in Fig. 1.1. Using all 10 mounting holes is recommended.

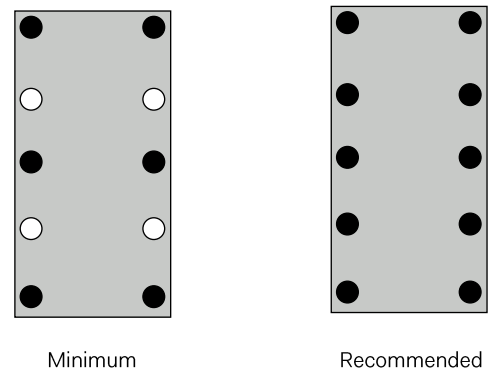

Fig. 1.1 Mounting hole requirement

Thermal interface material such a thermal pads or thermal grease shall be used to ensure proper cooling of the power supply.

Models without option -O (Active ORing), have open holes in the Aluminum baseplate. When using grease as thermal interface material, it could flow to the inside of unit. This is not dangerous, but not desirable. We recommended to not apply grease closer than 10mm from these holes. See Fig. 1.2 for location of open holes.

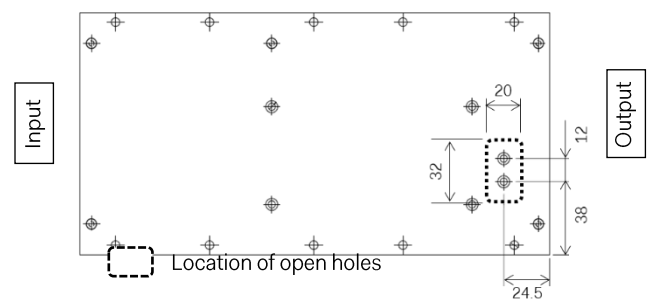

Fig. 1.2 Location of open hole on Aluminum Baseplate (Bottom view)

Remarks:

- There is no open holes in the Aluminum baseplate on units with option -O.

1.2 Isolation from conductive enclosure

There are dangerous voltages inside of the unit. Special attention needs to be considered when installing open type unit. Ensure proper isolation distances between the components and conductive enclosure.

$d = 4\text{mm min}$

If sufficient isolation distances cannot be secured, isolation sheet shall be added between components and external surfaces.

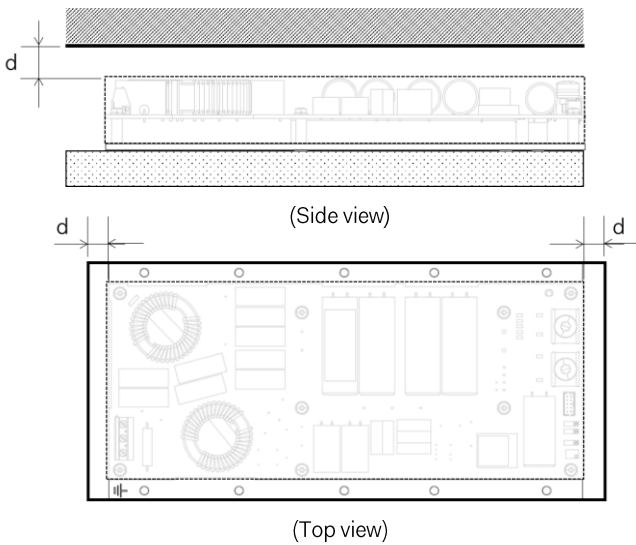

Fig. 1.3 Isolation distance

To optimize cooling airflow around the unit, ensure that the clearance between the power supply and surrounding objects is as large as possible.

1.3 Installation to fulfill EMC requirement

To ensure the best EMI-performance, the equipment should be mounted inside an earthed metal box. If it is not possible, install power supply and load on a earthed metal plate.

Input cables should be twisted and placed as close to the metal enclosure as possible.

Output cables of positive (+) and negative (-) should be twisted and separated from input cable as much as possible.

If radiation from input or output cable is an issue, use appropriate EMC ferrite clamp on input and/or output cable.

When function pins are connected to an user accessible point (i.e. panel switch, indicator circuit etc.), they must be protected from electrostatic discharging.

2. Derating

2.1 Derating curve by input voltage

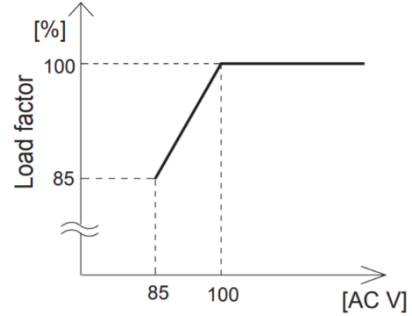

Fig. 2.1 Derating curve by input voltage

2.2 Temperature measuring point

For reliable and safe operation, make sure the maximum component temperature given in Table 2.1 are not exceeded. Temperature measuring point is shown in Fig. 2.2. Operating at the maximum temperature rating results in 3-years life expectancy.

Table 2.1 Maximum operating temperature

Point	Part name	Part Ref.	Maximum Temperature [°C]
A	Power Supply	-	See Fig. 2.3
B	Film Capacitor	C103	83
C	Aluminum Electrolytic Capacitor	C406	88
D	Aluminum Electrolytic Capacitor	C501	85

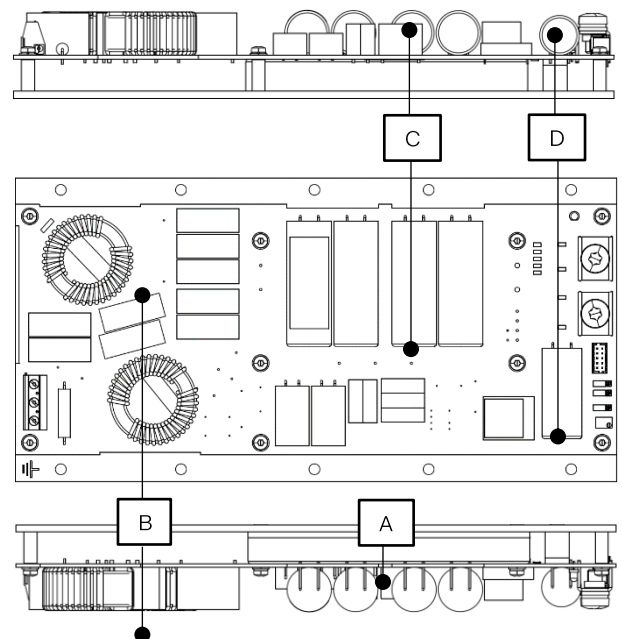

POWERBOX Industrial Line  
OF1700A Series  
700W Single Output  
AC-DC Baseplate Power Supply

Fig. 2.2 Temperature measuring points

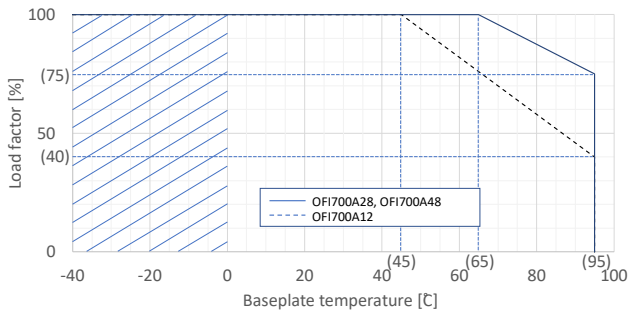

Fig. 2.3 Derating curve of point A (baseplate temperature)

\* Operation in the hatched area may cause significant level of ripple and ripple noise.

<Temperature measurement with cover option>

To measure internal temperature in the unit with option -N (with cover), it is necessary to remove cover to apply thermocouples on measuring points.

To remove cover, remove cables from input terminal and remove 4 screws on each corner. (see Fig. 2.4)

There is an isolation sheet over the input filter. When cover is re-installed, make sure that the isolation sheet is properly located.

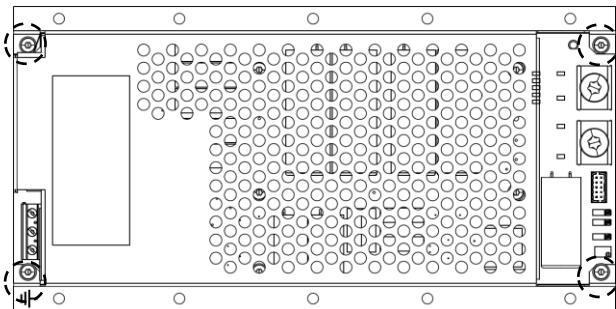

○ Screw location

Fig. 2.4 Screws to be removed for temperature measurement

### 3. Wiring

#### 3.1 Wiring input connector

##### (1) Built-in fuse

16 ampere AC fuse is built in on AC(L).

When operating the unit with a DC input voltage, an external high breaking DC fuse with a current rating lower than 16 A shall be installed.

The DC fuse shall be blown out in case of abnormal situation. Note that safety approvals for the unit do not cover operation with DC input.

##### (2) Wire

Connection capability of input connector.

- Input connector type : GMKDS 1.5 3-7.62 – 1717732 (Phoenix Contact)
- Connector cross section (solid and flexible) : 0.14 mm<sup>2</sup> – 1.5 mm<sup>2</sup>
- Conductor cross section (AWG) : AWG 26 – 16
- Conductor cross section (flexible, with ferrule) : 0.25 mm<sup>2</sup> – 1.0 mm<sup>2</sup>
- Stripping length : 6.5mm
- Torque : 0.5 – 0.6 Nm

Input current is dependent on input voltage and output current. So, choose appropriate thickness of input wire.

Influence against noise is improved when the input wire is twisted. In addition, make sure that input and output wire are separated.

##### (3) FG terminal

FG terminal on input connector shall be used for functional purpose. Make sure that mounting hole for safety ground on baseplate is properly connected, as required for class I equipment.

#### 3.2 Wiring output terminal

Assembly torque for output terminal screws is shown as below.

- Screw size : M6
- Recommended screw torque : 3.8 Nm

#### 3.3 Wiring function connector

Fig. 3.1 shows pin assignment and Table 3.1 states pin configuration of function connector X506.

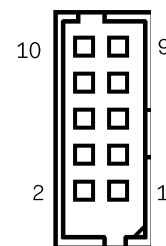

Fig. 3.1 X506 Pin assignment

Table 3.1 Function of connector X506

Pin No.	Name	Function
1	TRM	Refer to Section 4.6
2	-S	Refer to Section 4.8
3	IOG	Refer to Section 4.9
4	DC OK	Refer to Section 4.9
5	AUX-RC	Refer to Section 4.7
6	RC1	Refer to Section 4.7
7	AUX	AUX(12V), refer to Section 4.10
8	RC2	Refer to Section 4.7
9	+S	Refer to Section 4.8
10	AUXG	Ground for AUX, refer to Section 4.10

POWERBOX Industrial Line  
OF1700A Series  
700W Single Output  
AC-DC Baseplate Power Supply

<Connector information>

Part number : 87831-1041 (Molex)

<Appropriate mating connector and pin>

Part number : 51110-1056 (Molex)

Pin : 50394-8051 (Molex)

For connecting X506, H-SN-61 (Manufactured by Cosel) is available.

<https://en.cosel.co.jp/product/optionparts/H-SN-61/>

3.4 Jumper factory setting

Jumpers on X503, X504 and X601 are placed as shown in Fig. 3.2 at factory.

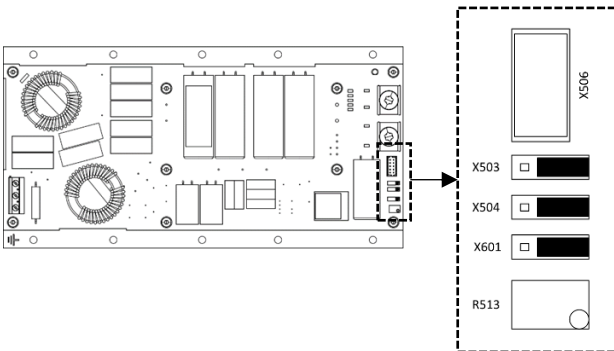

Fig. 3.2 Jumper placement at factory

3.5 Output ripple and ripple noise measurement

The specified ripple and ripple noise are measured by the method shown in Fig.3.3.

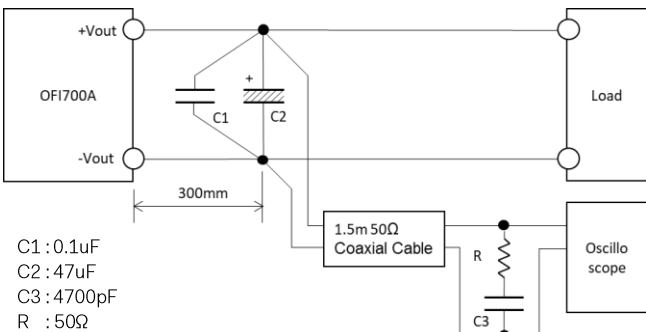

Fig.3.3 Method of Measuring Output ripple and ripple noise

Remarks:

- When the ambient temperature is lower than -20°C, the output ripple may become unstable during heating up.

4. Functions

4.1 Input voltage range

Unit will operate with an input voltage range from 85 Vac to 264 Vac. The voltage range for a valid safety approval is 100 - 240 Vac (50/60Hz).

Remarks:

- Be aware that use of voltages other than those listed above may

result in the unit not operating according to specifications or may cause damage or dangerous situations. Avoid square waveform input voltage, commonly used in UPS and inverters.

When the input voltage is DC, high breaking an external DC fuse which current rating is lower than 16 A shall be used.

Note that safety approvals for the unit do not cover operation with DC input.

4.2 Inrush current limiting

An inrush current limiting circuit is built in.

If you need to use a switch on the input side, select one that can withstand the inrush current.

Thyristor technique is used in the inrush current limiting circuit. When you turn the power ON/OFF repeatedly within a short period of time, have enough intervals so that the inrush current limiting circuit becomes operative.

When the input power is turned on, the primary inrush current and secondary inrush current will be generated due to the thyristor technique used for the inrush current limiting circuit.

4.3 Overcurrent protection

Overcurrent protection is built-in and comes into effect when drawing over 105% of the rated current.

Overcurrent protection prevents the unit from short circuit and overcurrent condition. The unit automatically recovers when the fault condition is cleared.

When the output voltage drops at overcurrent, the average output current is reduced by hiccup operation of power supply.

4.4 Overvoltage protection

Overvoltage protection circuit is built in. If the overvoltage protection circuit is activated, shut down the input voltage, wait a certain time and turn on the AC input again to recover the output voltage.

The recovery time is 3 minutes or more.

However, it varies depending on such factors as input voltage value at the time of the operation.

Remarks:

- Devices inside the power supply might fail when voltage which is higher than rated output voltage is applied to output terminal of the power supply. This could happen when the customer tests the overvoltage performance of the unit.
- Do not apply higher than 1.4 times of rated output voltage externally. It may cause failure of internal components.
- With option -O, active ORing circuit disconnects the output from the external voltage. So, overvoltage protection shall not activate even if external voltage is applied. Therefore, it is not possible to test overvoltage performance for the unit with option -O by applying external voltage.

4.5 Thermal protection

When the baseplate temperature exceeds the maximum allowable temperature shown in Fig. 2.3, thermal protection will be activated and

POWERBOX Industrial Line  
OF1700A Series  
700W Single Output  
AC-DC Baseplate Power Supply

simultaneously shut down the output.

When the thermal protection is activated, turn off the input voltage and eliminate all the overheating conditions. To recover the output voltage, let the power supply cool down before turning on the input voltage again.

4.6 Output voltage adjustment

(a) Adjust by potentiometer

To increase output voltage, turn the built-in potentiometer clockwise. To decrease the output voltage, turn it counter clockwise.

(b) Adjust by external voltage source

To adjust the output voltage by external voltage source, apply it between TRM and -S terminal.

Necessary external voltage can be calculated by the equation shown in Table 4.1 and Fig. 4.1.

Table 4.1 Equation of Output voltage by external signal

Vout	Equation of output voltage setting
12V	$V_o = -1.526 \times V_{TRM} + 15.91$
28V	$V_o = -3.367 \times V_{TRM} + 36.44$
48V	$V_o = -6.010 \times V_{TRM} + 63.09$

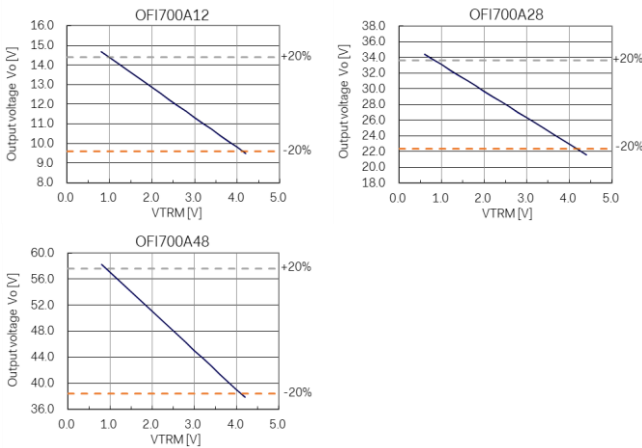

Fig. 4.1 Output voltage by external voltage source

Remarks:

- Overvoltage protection shall be activated when the output voltage is adjusted exceeding output voltage adjustment range of +20%.
- Apply external voltage before turning on input voltage.
- External voltage source shall be low impedance since current is drawn through TRM terminal.

4.7 Remote ON/OFF

Remote ON/OFF is built in.

Remote ON/OFF is operated by applying a voltage between RC1 and RC2 pin.

When jumper on X601 is set shown in Fig. 4.2 (a), remote control function is disabled, and output voltage is always provided when input voltage is applied.

When using remote control function, move jumper on X601 to the position shown in Fig. 4.2 (b).

(a) Disable RC function (Factory setting)

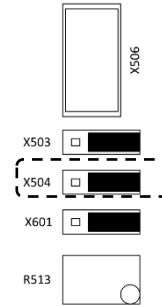

(b) Enable RC function

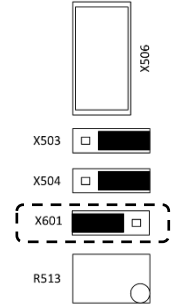

Fig. 4.2 X601 Jumper position

When the output shuts off by overvoltage protection or thermal protection, it can be recovered by toggling Remote ON/OFF signal.

Remote ON/OFF circuit (RC1, RC2) and AUX (AUX, AUX\_RC, AUXG) are isolated from Input, Output, FG and other function terminals.

Sink current of RC1 must be kept up to 12mA.

Table 4.2 Remote Control Logic

No.	Item	Remote Control Logic		
1	Connection method	Fig. 4.4(a)	Fig. 4.4(b)	Fig. 4.4(c)
2	Isolation	INPUT – RC, AUX OUTPUT – RC, AUX		
3	Reference pin	AUXG	RC2	AUXG, RC2
4	Output ON	SW OPEN (0.1mA max)		SW SHORT (0.5V max)
5	Output OFF	SW SHORT (2mA min)		SW OPEN (0.1mA max)

Internal circuit of remote control is shown in Fig. 4.3.

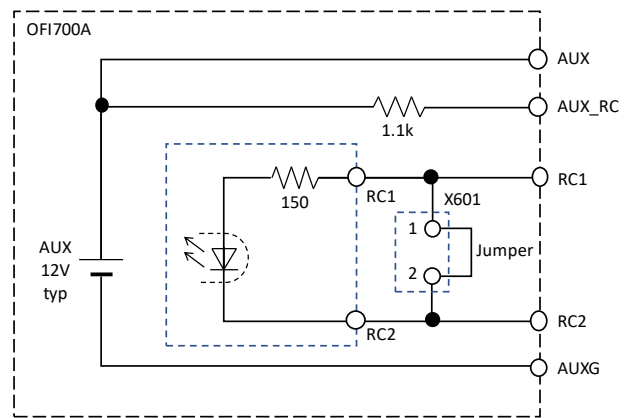
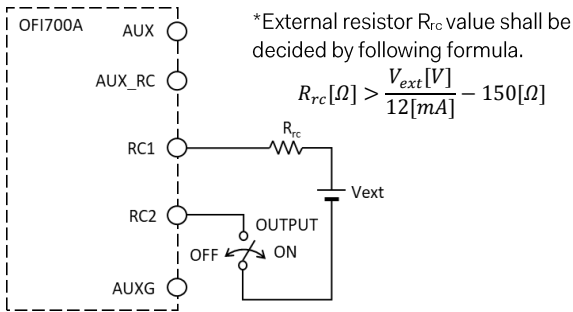

Fig. 4.3 Internal circuit diagram of Remote Control



POWERBOX Industrial Line  
OF1700A Series  
700W Single Output  
AC-DC Baseplate Power Supply

(a) Use external voltage source (Positive logic)



(b) Use AUX\_RC (Negative logic)

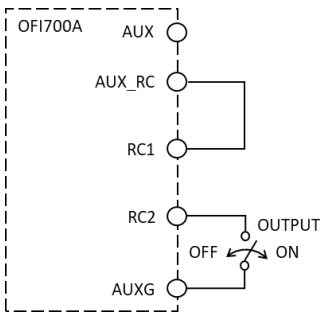

(c) Use AUX\_RC (Positive logic)

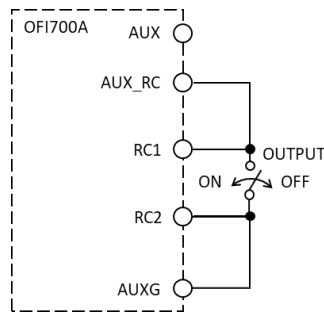

Fig. 4.4 Example of connecting remote ON/OFF circuit

Remarks:

- Do not connect AUX to RC1 directly. It may cause damages on internal circuit.

4.8 Remote sensing

Remote sensing is built in.

When remote sensing is not used, make sure that jumpers are placed on X503 and X504 as shown in Fig. 4.5(a).

When using remote sensing function, place jumpers on X503 and X504 as shown in Fig. 4.5(b), then connect +S and -S terminal on X506 to sensing point.

(a) Disable Remote Sensing (Factory setting)

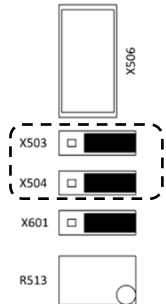

(b) Enable Remote Sensing

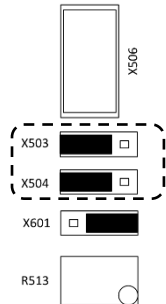

Fig. 4.5 X503 and X504 Jumper position

Remarks:

- Twisted-pair wire or shielded wire should be used for sensing wire.

- If sensing wire is not properly connected, overvoltage protection may be activated. In this case, follow recovery method against overvoltage protection.

- Use proper thickness cable for the wiring between the power supply output and load. Line drop between the power supply and the load should be less than 0.5V.

- Voltage between +VOUT and -VOUT should be kept within the output voltage adjustment range.

- If the sensing lines become short circuit, heavy current will be drawn, and the sensing circuit may be damaged. The problem can be prevented by installing the protection parts near the load.

- As wiring or load impedance may generate oscillation or large

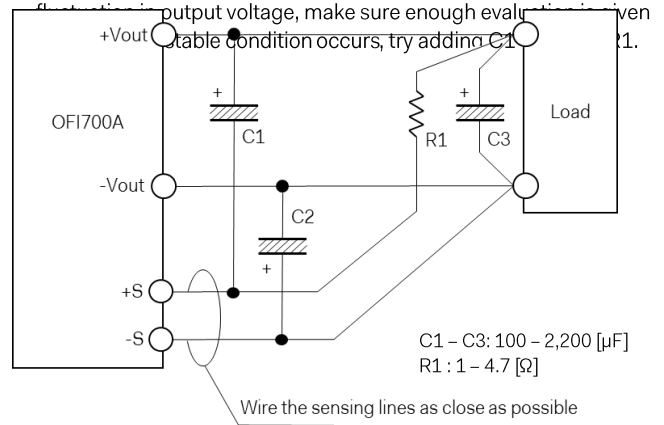

Fig. 4.6 When using remote sensing function

4.9 Signal output (LED / DC OK / IOG)

LED turns on when the output voltage is generated.

DC OK signal is available to confirm whether the output voltage is properly generated or not.

Inverter operating monitor (IOG) is available to monitor the condition of internal switching operation.

Specification of DC OK and IOG is shown in Table 4.5.

Table 4.5 Specification of DC OK and IOG

No.	Item	DC OK	IOG
1	Function	Normal operation "L"	
		$V_o < 50\%$ of rated voltage "H"	Refer to Note
2	Base pin	-S	
3	Level voltage "L"	0.5V max at 10mA	
4	Level voltage "H"	Open collector	
5	Maximum sink current	10mA max	
6	Maximum applied voltage	35V max	

Note: The following conditions make the IOG signal changes from "L" to "H" within 1 second.

- Malfunction of inverter

POWERBOX Industrial Line  
OF1700A Series  
700W Single Output  
AC-DC Baseplate Power Supply

- Output voltage is rapidly dropped by adjusting output voltage

#### 4.10 Auxiliary Power (AUX)

Auxiliary power (AUX: 12V 0.1A) is available for peripheral circuit operation.

AUX circuit (AUX, AUX\_RC, AUXG) is isolated from input, output, FG, and function terminals.

To avoid permanent damage or malfunction, make sure that the AUX output current doesn't exceed 0.1A.

The AUX output voltage may vary between 10 ~ 14V depending on output current from AUX.

### 5. Series / Parallel Operation

#### 5.1 Series operation

Series operation is possible by connecting the output of two or more power supplies as shown in Fig. 5.1.

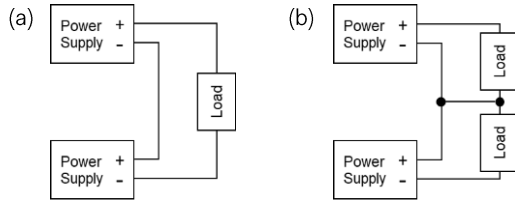

Fig. 5.1 Example of Series operation

Output current in series connection should be lower than the lowest current in each unit.

When one of unit's output becomes short circuit during series operation, high voltage may be applied to rest of units. To avoid further damages, consider adding a protection method that can immediately stop operation.

Make sure that the combined total output voltage is less than 120Vdc.

The classification of Electrical energy source of output voltage for OF1700A12 and OF1700A28 is ES1, and OF1700A48 is ES2. So, make sure the safety requirement when total output voltage exceeds 60Vdc.

#### 5.2 Parallel operation

Parallel operation is NOT possible.

#### 5.3 Redundancy operation

1 + 1 redundancy operation is possible by wiring as shown in Fig. 5.2.

When using option -O, ORing MOSFET is implemented into the unit, so it is possible to connect each output directly for 1+1 redundancy operation. (Fig. 502(a))

When using without option -O, add diode on +Vout of each power supply. (Fig. 5.2(b))

Even a slight difference in output voltage can affect the balance between the values of  $I_1$  and  $I_2$ .

Make sure that the maximum value of  $I_3$  does not exceed the rated current of a single power supply.

$$I_1 + I_2 = I_3 \leq \text{Rated current}$$

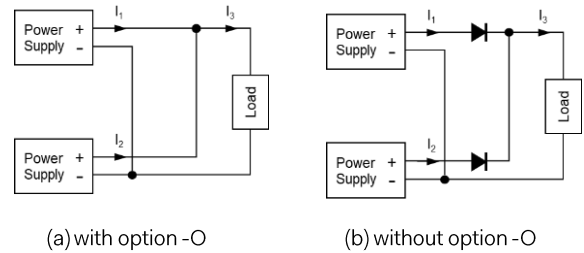

Fig. 5.2 example of 1+1 Redundancy operation

### 6. Life Expectancy and Warranty

#### 6.1 Life Expectancy

Life expectancy is strongly dependent to operating temperature and cooling conditions.

To make sure life expectancy, measure temperature of Electrolytic capacitors shown in Fig. 6.1 and calculate by following formula.

$$L = L_{105} \times 2^{\frac{105 - T_{cap}}{10}}$$

where

L : Life expectancy [hour]

$L_{105}$  : Endurance at 105°C [hour], see table 6.1

$T_{cap}$  : Temperature of Electrolytic capacitor[°C]

Table 6.1 Endurance of Electrolytic capacitor

Item	C406	C501
$L_{105}$ Endurance at 105°C	12,000h	8,000h

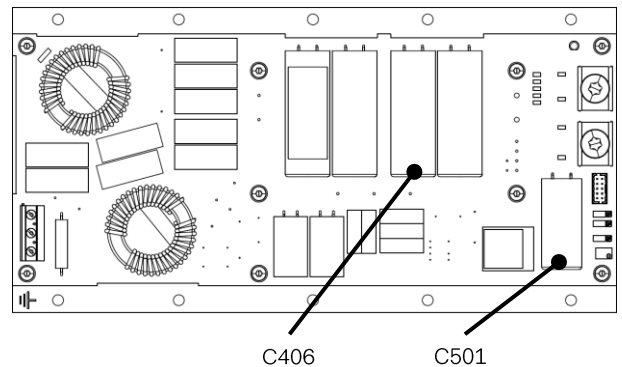

Fig. 6.1 Temperature measuring point for Life expectancy

#### 6.2 Warranty

Warranty term is 3 years.

## 7. Option and Others

### 7.1 Options

#### (1) Option -N: with Metal cover

The metal cover option improves radiated noise from the unit and gives better mechanical protection.

#### (2) Option -O: with Active ORing

ORing MOSFET is added. It enables to connect each output of same model to use as redundancy operation without additional components.

### 7.2 12V output for pulse current

When baseplate temperature is less than 65°C, 12V output can draw pulse current with condition below.

<Condition>

$$t_1 \leq 10 \text{ [sec]}$$

$$I_{ave} \leq \text{Less than 75\% of rated output current (43.8 [A])}$$

$$\text{Duty} = t_1 / (t_1 + t_2) \times 100 \text{ [\%]} \leq 35\text{[\%]}$$

$$I_{max} \leq \text{Rated output current (58.4 [A])}$$

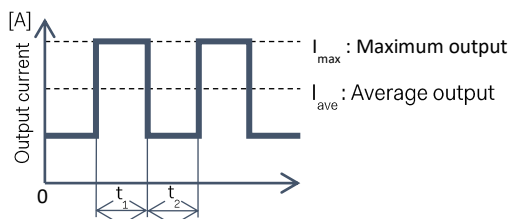

Fig. 7.1 Pulse current