

# P R B X

## POWERBOX Industrial Line PMF30W Series 30W 4:1 Single Output DC/DC Converter Manual

### Table of Contents

Output specification	P2
Input specification	P3
General specification	P4
Environmental specifications	P4
EMC characteristics	P4
Characteristic curves	P5
Output voltage adjustment	P25
Input source impedance	P26
Output over current protection	P27
Output short circuit protection	P27
Output over voltage protection	P27
Thermal considerations	P27
Heat sink considerations	P28
Remote on/off control	P29
EMS considerations	P30
Mechanical data	P30
Recommended pad layout	P30
Soldering considerations	P30
Packaging information	P31
Safety and installation instruction	P31
MTBF and reliability	P31
Recommended external EMI filter	P32

### Introduction

The PMF30W single output DC/DC converters provide up to 30 watts of output power in an industry standard package and footprint. These units are specifically designed to meet the power needs of low profile. All models feature with 4:1 ultra wide input voltage of 9~36VDC and 18~75VDC, comprehensively protected against over-current, over-voltage input under-voltage and over temperature protection conditions, and adjustable output voltage.

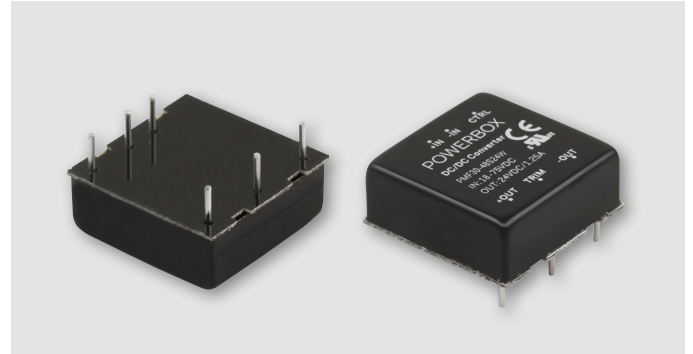

### DC/DC Converter Features

- 30 Watts maximum output power
- Ultra low quiescent current
- Single output current up to 7A
- Small size and low profile: 1.0 x 1.0 x 0.39 inch
- High efficiency up to 92%
- 4:1 ultra wide input voltage range
- Six-sided continuous shield
- Fixed switching frequency
- Input to output isolation 1600 VDC
- Over temperature protection
- No minimum load required
- High power density
- Input under voltage protection
- Output over voltage protection
- Output over current protection
- Output short circuit protection
- Remote on/off control
- Adjustable output voltage
- Compliant to RoHS II & REACH

### Options

- Positive logic remote on/off
- Without on/off control pin
- Without trim pin
- Heat-sink available for extended operation

POWERBOX Industrial Line  
 PMF30W Series  
 30W 4:1 Single Output  
 DC/DC Converter  
 Manual

Output Specifications

Parameters	Model	Min	Typ	Max	Unit
Output voltage ( $V_{in(nom)}$ ); full load; $T_a=25^\circ\text{C}$ )	□□S3P3W	3.267	3.3	3.333	VDC
	□□S05W	4.95	5	5.05	VDC
	□□S12W	11.88	12	12.12	VDC
	□□S15W	14.85	15	15.15	VDC
	□□S24W	23.76	24	24.24	VDC
<i>Output regulation</i>					
Line ( $V_{in(min)}$ to $V_{in(max)}$ ); full load)	All	-0.2		+0.2	%
Load (0% to 100% of full load)	All	-0.2		+0.2	%
Load (10% to 90% of full load)	All	-0.1		+0.1	%
<i>Output ripple and noise</i>					
Peak to peak (20MHz bandwidth)					
With a 22 $\mu\text{F}/25\text{V}$ X7R MLCC	□□S3P3W		75	100	mVp-p
With a 22 $\mu\text{F}/25\text{V}$ X7R MLCC	□□S05W		75	100	mVp-p
With 2 pcs 22 $\mu\text{F}/25\text{V}$ X7R MLCC	□□S12W		75	100	mVp-p
With 2 pcs 22 $\mu\text{F}/25\text{V}$ X7R MLCC	□□S15W		75	100	mVp-p
With 2 pcs 6.8 $\mu\text{F}/50\text{V}$ X7R MLCC	□□S24W		75	100	mVp-p
Voltage adjustability	□□S15W	-10		+20	% of $V_{out}$
	□□S24W	-10		+10	% of $V_{out}$
Temperature coefficient	All	-0.02		+0.02	%/ $^\circ\text{C}$
Output voltage overshoot ( $V_{in(min)}$ to $V_{in(max)}$ full load; $T_a=25^\circ\text{C}$ )	All			5	% of $V_{out}$
<i>Dynamic load response (<math>V_{in(nom)}</math>); <math>T_a=25^\circ\text{C}</math>)</i>					
Load step change from 75% to 100% or 100 to 75% of full load					
Peak deviation	□□S3P3W		5		% of $V_{out}$
	□□S05W		5		% of $V_{out}$
	□□S12W		5		% of $V_{out}$
	□□S15W		5		% of $V_{out}$
	□□S24W		5		% of $V_{out}$
Setting time ( $V_o < 10\%$ peak deviation)	All		250		$\mu\text{s}$
Output current	□□S3P3W	0		7000	mA
	□□S05W	0		6000	mA
	□□S12W	0		2500	mA
	□□S15W	0		2000	mA
	□□S24W	0		1250	mA
Output capacitance load	□□S3P3W			10000	$\mu\text{F}$
	□□S05W			7200	$\mu\text{F}$
	□□S12W			1200	$\mu\text{F}$
	□□S15W			1000	$\mu\text{F}$
	□□S24W			375	$\mu\text{F}$
Output over voltage protection (continuous clamped)	□□S3P3W	3.7		5.4	VDC
	□□S05W	5.6		7.0	VDC
	□□S12W	13.5		19.6	VDC
	□□S15W	18.3		22.0	VDC
	□□S24W	29.1		32.5	VDC
Output over current protection	All		170		% of FL
Output short circuit protection	All	Continuous, automatic recovery			

### Input Specifications

Parameters	Model	Min	Typ	Max	Unit
<i>Operating input voltage</i>					
Continuous	24S□□W	9	24	36	VDC
	48S□□W	18	48	75	VDC
Transient (1sec, max)	24S□□W			50	VDC
	48S□□W			100	VDC
Input standby current (Typ. value at Vin(nom); no load)	24S3P3W		10		mA
	24S05W		10		mA
	24S12W		10		mA
	24S15W		10		mA
	24S24W		10		mA
	48S3P3W		10		mA
	48S05W		10		mA
	48S12W		8		mA
	48S15W		8		mA
	48S24W		8		mA
Under voltage lockout turn-on threshold	24S□□W			9	VDC
	48S□□W			18	VDC
Under voltage lockout turn-off threshold	24S□□W		8		VDC
	48S□□W		16		VDC
Input reflected ripple current (5 to 20MHz, 12μH source impedance)	All		30		mA <sub>p-p</sub>
<i>Start up time (Vin(nom) and constant resistive load)</i>					
Power up	All			30	ms
Remote on/off	All			30	ms
<i>Remote ON/OFF control (The Ctrl pin voltage is referred to -INPUT)</i>					
Positive logic (option)					
On/Off pin high voltage (remote ON)	□□S□□W-A	Open or 3 ~ 15VDC			
On/Off pin low voltage (remote OFF)	□□S□□W-E	Short or 0 ~ 1.2VDC			
Negative logic (standard)					
On/Off pin low voltage (remote ON)	□□S□□W	Short or 0 ~ 1.2VDC			
On/Off pin high Vltage (remote OFF)	□□S□□W-C	Open or 3 ~ 15VDC			
Input current of remote control pin		-0.5		1.0	mA
Remote off state input current			2.0		mA

### General Specifications

Parameters	Model	Min	Typ	Max	Unit
Efficiency (Vin(nom), full load; Ta=25°C)	24S3P3W		88		%
	24S05W		89		%
	24S12W		89		%
	24S15W		89		%
	24S24W		90		%
	48S3P3W		88		%
	48S05W		90		%
	48S12W		90		%
	48S15W		91		%
	48S24W		92		%
<i>Isolation voltage (1 minute)</i>					
Input to output	All	1600			VDC
Input to case, output to case	All	1000			VDC
Isolation resistance (500VDC)	All	1			GΩ
Isolation capacitance	All			1500	pF
Switching frequency	□□S3P3W	248	275	303	kHz
	□□S05W				kHz
	Others	297	330	363	kHz
Weight	All		16.5		g
MTBF MIL-HDBK-217F	All		1.259 x 10 <sup>6</sup>		hours
Safety approvals	All	UL60950-1, EN60950-1, IEC60950-1			
Case material	All	Copper			
Base material	All	FR4 PCB			
Potting material	All	Silicone (UL94-V0)			

### Environmental Specifications

Parameters	Model	Min	Typ	Max	Unit
<i>Operating ambient temperature</i>					
Without derating	All	-40		50	°C
With derating	All	50		100	°C
Storage temperature	All	-55		125	°C
Over temperature protection	All		115		°C
<i>Thermal impedance (natural convection with vertical direction)</i>					
Without heat-sink	All		15.0		°C/W
With heat-sink	All		13.8		°C/W
Relative humidity	All	5		95	% RH
Thermal shock	All	MIL-STD-810F			
Vibration	All	MIL-STD-810F			

### EMC Characteristics

Parameters	Standard	Condition	Level
EMI	EN55022	With external input filter	Class A, Class B
ESD	EN61000-4-2	Air	±8kV
		Contact	±6kV
Radiated Immunity	EN61000-4-3	10V/m	Perf. Criteria A
Fast transient	EN61000-4-4	±2kV	Perf. Criteria A
Surge	EN61000-4-5	±2kV	Perf. Criteria A
Conducted immunity	EN61000-4-6	10V r.m.s	Perf. Criteria A
Power frequency magnetic field	EN61000-4-8	100A/m continuous;	Perf. Criteria A
		1000A/m 1 second	

POWERBOX Industrial Line  
 PMF30W Series  
 30W 4:1 Single Output  
 DC/DC Converter  
 Manual

All test conditions are at 25°C. The figures are identical for PMF30-24S3P3W

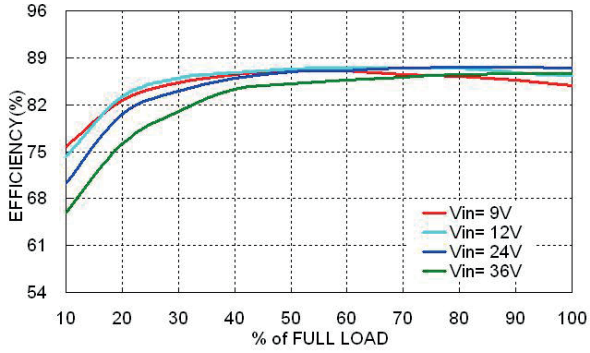

Efficiency versus Output Current

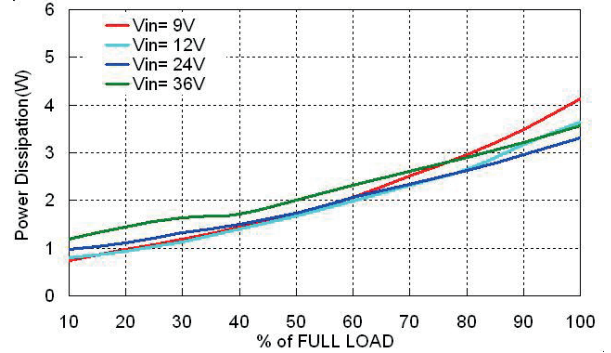

Power Dissipation versus Output Current

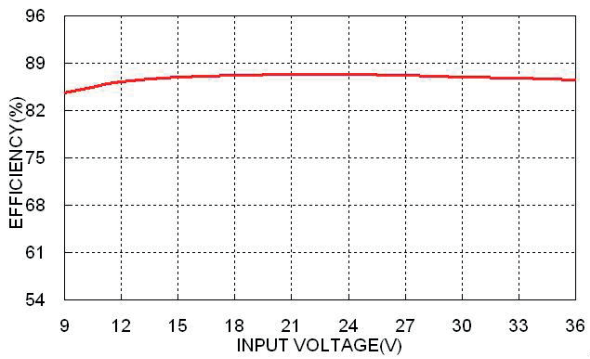

Efficiency versus Input Voltage  
Full Load

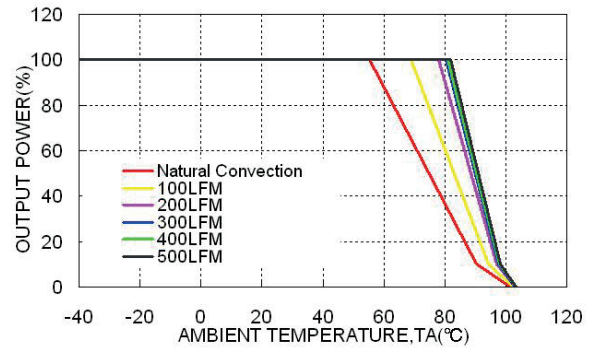

Derating Output Current versus Ambient Temperature and Airflow  
Vin(nom)

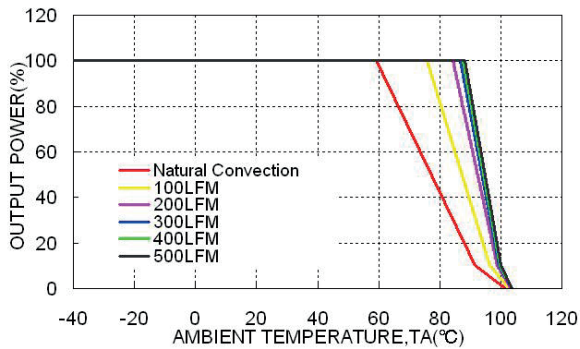

Derating Output Current versus Ambient Temperature with  
Heat-sink and Airflow, Vin(nom)

All test conditions are at 25°C. The figures are identical for PMF30-24S3P3W

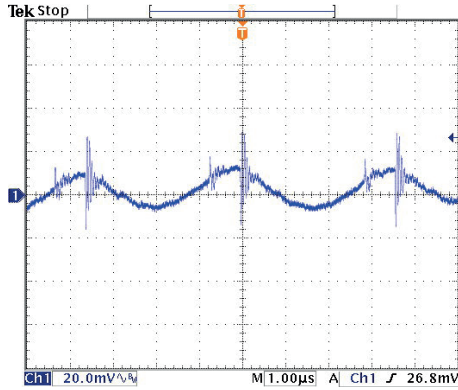

Typical Output Ripple and Noise.  
 $V_{in}(nom)$ ; Full Load

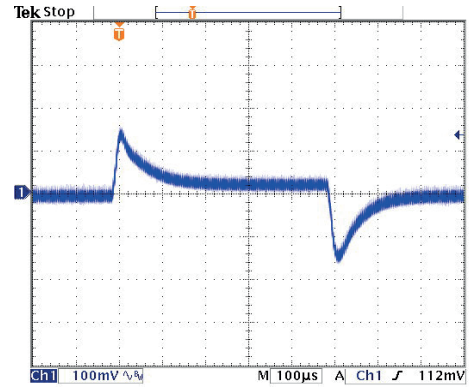

Transient Response to Dynamic Load Change from  
 100% to 75% to 100% of Full Load;  $V_{in}(nom)$

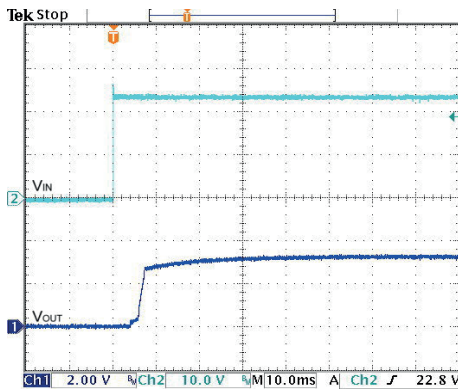

Typical Input Start-Up and Output Rise Characteristic  
 $V_{in}(nom)$ ; Full Load

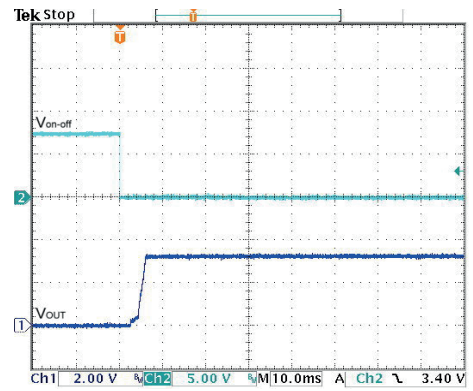

Using ON/OFF Voltage Start-Up and Output Rise Characteristic  
 $V_{in}(nom)$ ; Full Load

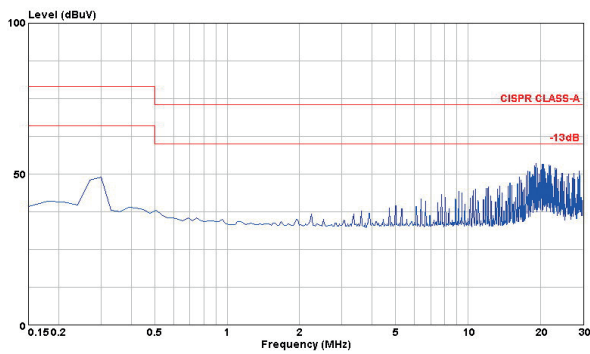

Conduction Emission of EN55022 Class A  
 $V_{in}(nom)$ ; Full Load

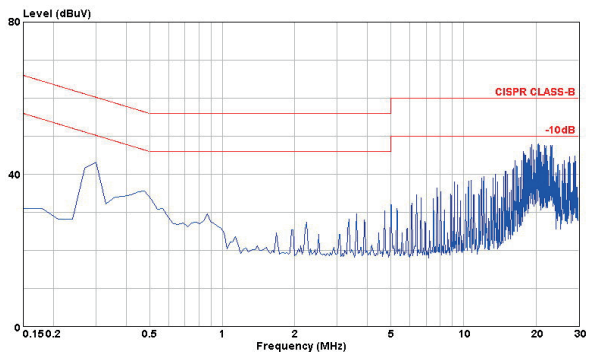

Conduction Emission of EN55022 Class B  
 $V_{in}(nom)$ ; Full Load

POWERBOX Industrial Line  
 PMF30W Series  
 30W 4:1 Single Output  
 DC/DC Converter  
 Manual

All test conditions are at 25°C. The figures are identical for PMF30-24S05W

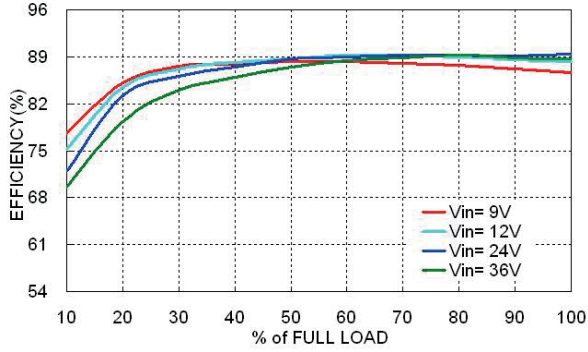

Efficiency versus Output Current

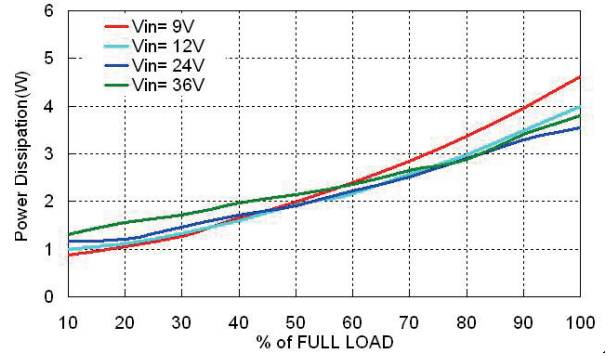

Power Dissipation versus Output Current

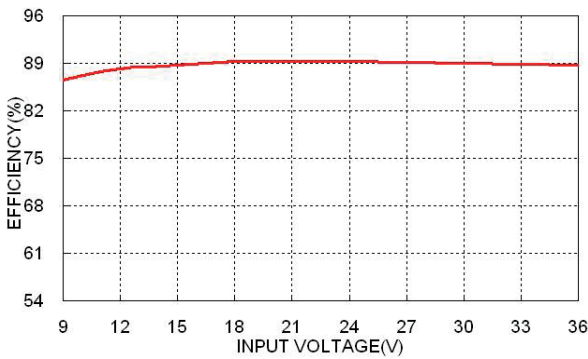

Efficiency versus Input Voltage  
Full Load

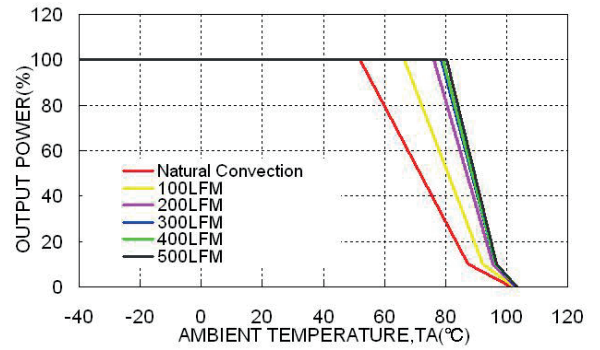

Derating Output Current versus Ambient Temperature and Airflow  
Vin(nom)

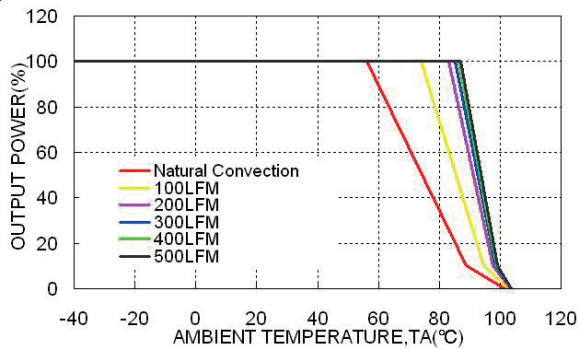

Derating Output Current versus Ambient Temperature with  
Heat-sink and Airflow, Vin(nom)

POWERBOX Industrial Line  
 PMF30W Series  
 30W 4:1 Single Output  
 DC/DC Converter  
 Manual

All test conditions are at 25°C. The figures are identical for PMF30-24S05W

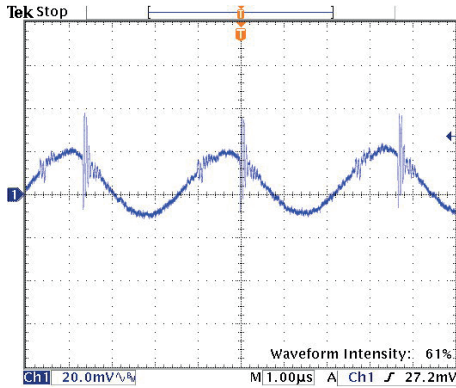

Typical Output Ripple and Noise.  
 $V_{in}(nom)$ ; Full Load

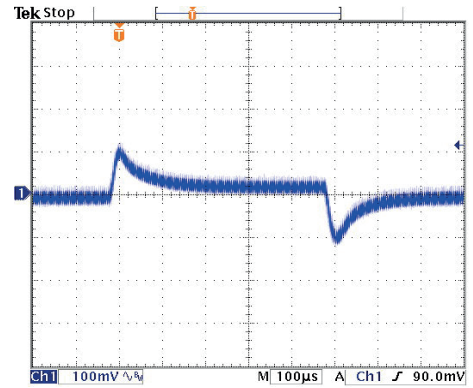

Transient Response to Dynamic Load Change from  
 100% to 75% to 100% of Full Load;  $V_{in}(nom)$

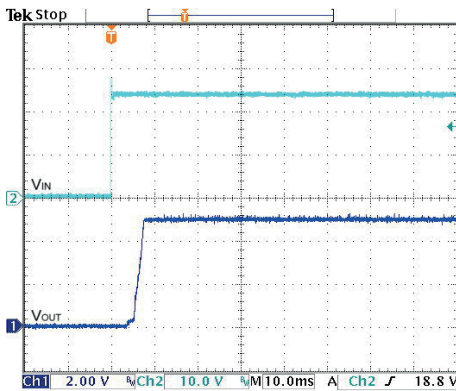

Typical Input Start-Up and Output Rise Characteristic  
 $V_{in}(nom)$ ; Full Load

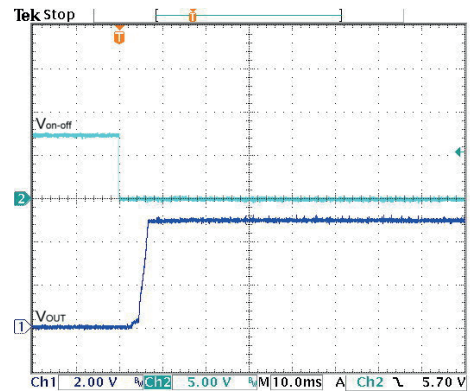

Using ON/OFF Voltage Start-Up and Output Rise Characteristic  
 $V_{in}(nom)$ ; Full Load

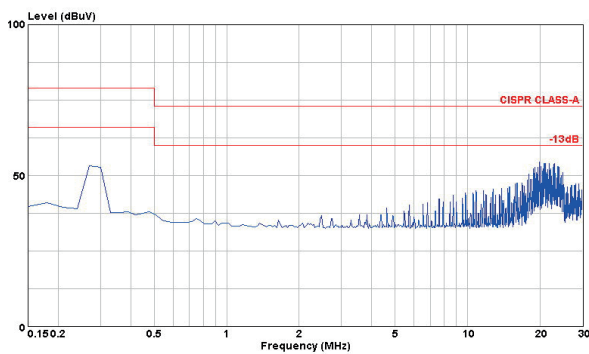

Conduction Emission of EN55022 Class A  
 $V_{in}(nom)$ ; Full Load

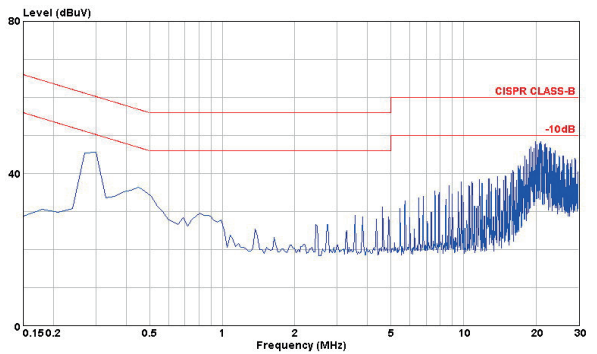

Conduction Emission of EN55022 Class B  
 $V_{in}(nom)$ ; Full Load



POWERBOX Industrial Line  
 PMF30W Series  
 30W 4:1 Single Output  
 DC/DC Converter  
 Manual

All test conditions are at 25°C. The figures are identical for PMF30-24S12W

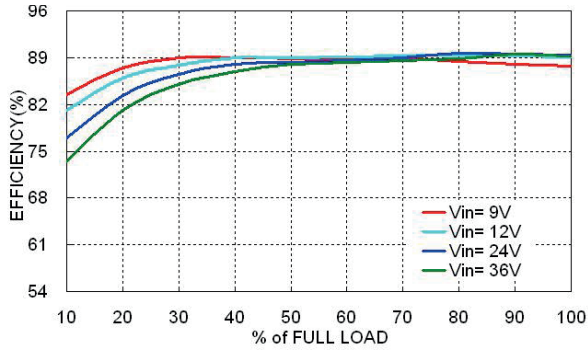

Efficiency versus Output Current

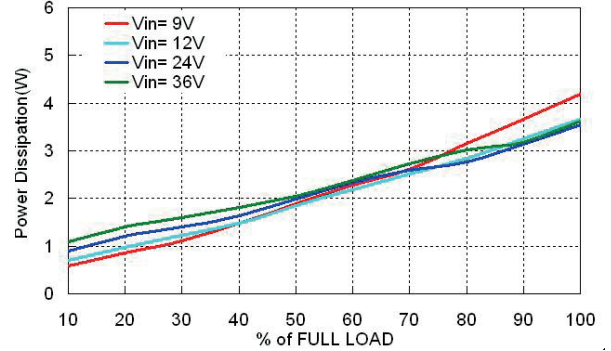

Power Dissipation versus Output Current

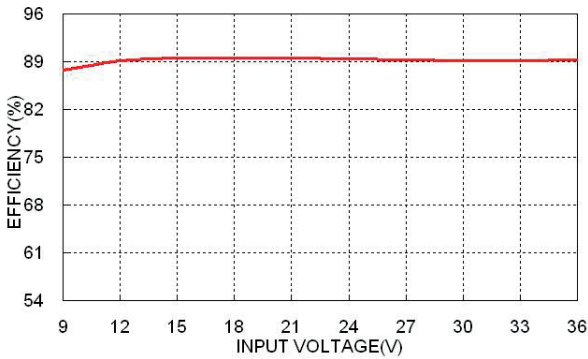

Efficiency versus Input Voltage  
Full Load

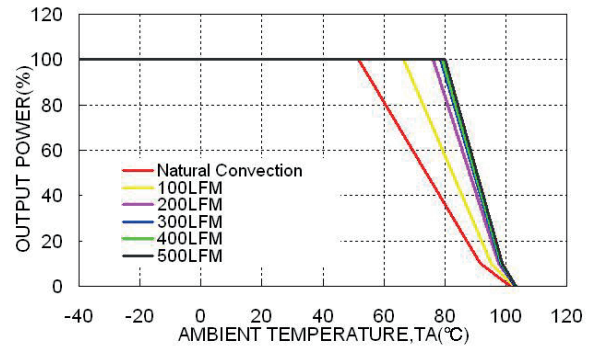

Derating Output Current versus Ambient Temperature and Airflow  
Vin(nom)

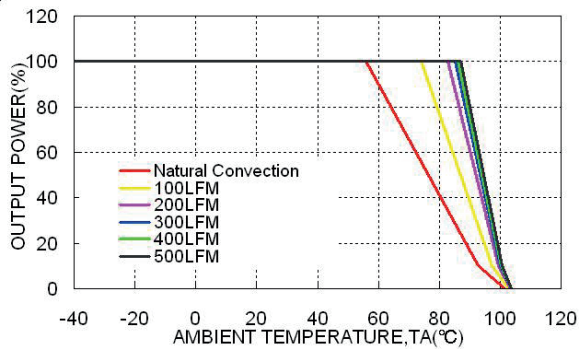

Derating Output Current versus Ambient Temperature with  
Heat-sink and Airflow, Vin(nom)

POWERBOX Industrial Line  
 PMF30W Series  
 30W 4:1 Single Output  
 DC/DC Converter  
 Manual

All test conditions are at 25°C. The figures are identical for PMF30-24S12W

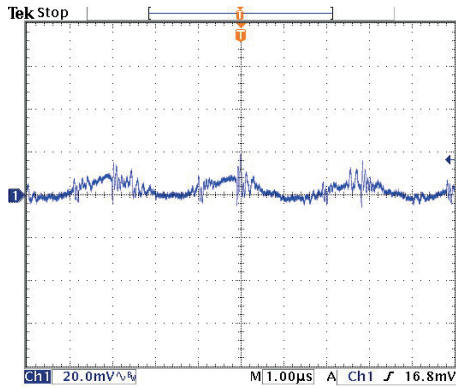

Typical Output Ripple and Noise.  
 $V_{in}(nom)$ ; Full Load

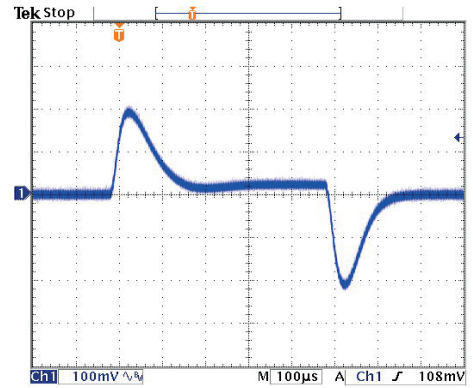

Transient Response to Dynamic Load Change from  
 100% to 75% to 100% of Full Load;  $V_{in}(nom)$

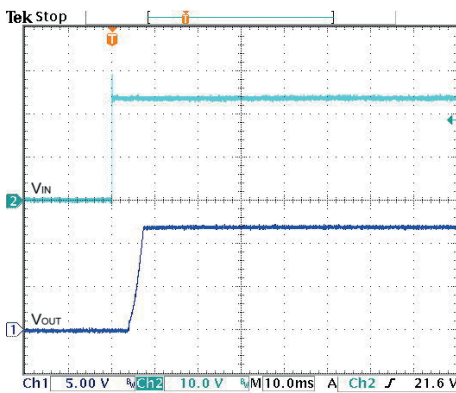

Typical Input Start-Up and Output Rise Characteristic  
 $V_{in}(nom)$ ; Full Load

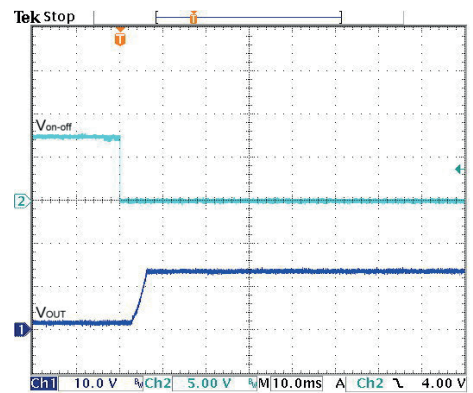

Using ON/OFF Voltage Start-Up and Output Rise Characteristic  
 $V_{in}(nom)$ ; Full Load

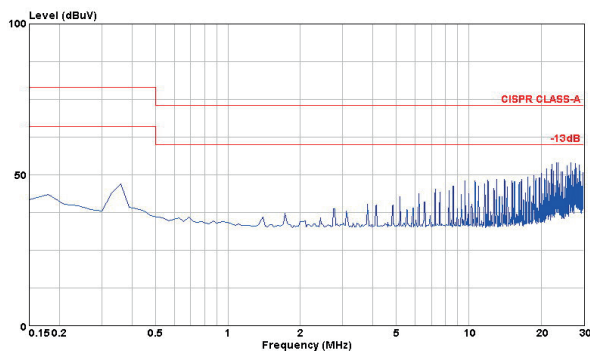

Conduction Emission of EN55022 Class A  
 $V_{in}(nom)$ ; Full Load

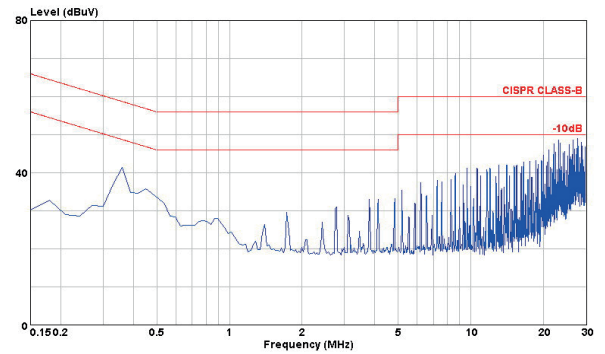

Conduction Emission of EN55022 Class B  
 $V_{in}(nom)$ ; Full Load

POWERBOX Industrial Line  
 PMF30W Series  
 30W 4:1 Single Output  
 DC/DC Converter  
 Manual

All test conditions are at 25°C. The figures are identical for PMF30-24S15W

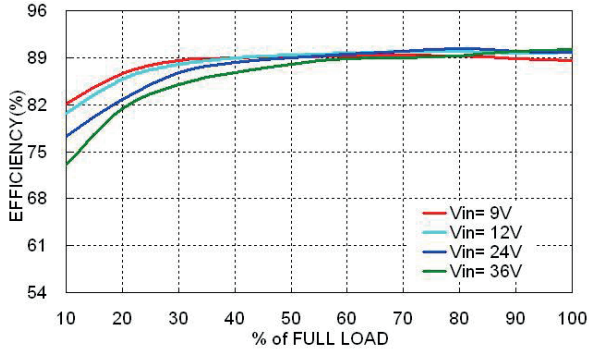

Efficiency versus Output Current

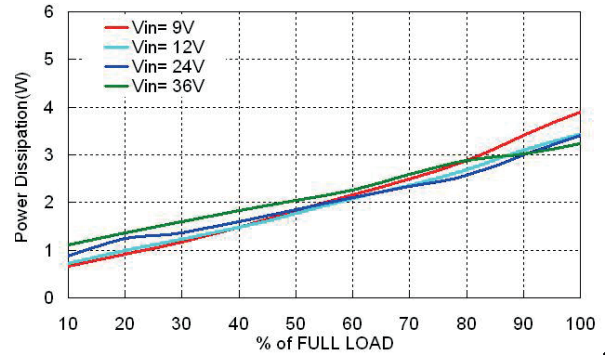

Power Dissipation versus Output Current

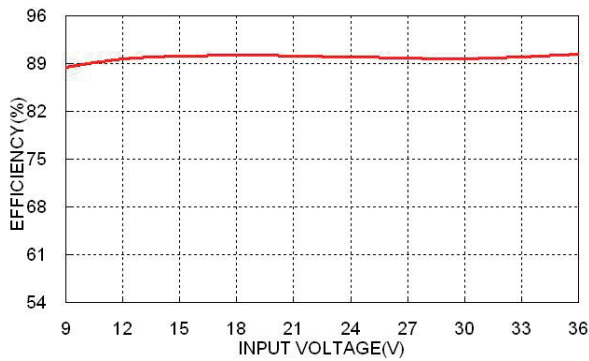

Efficiency versus Input Voltage  
Full Load

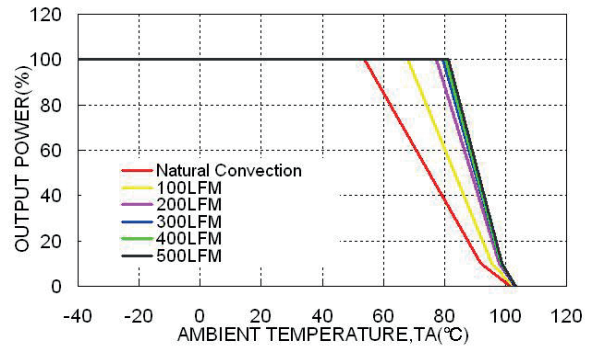

Derating Output Current versus Ambient Temperature and Airflow  
Vin(nom)

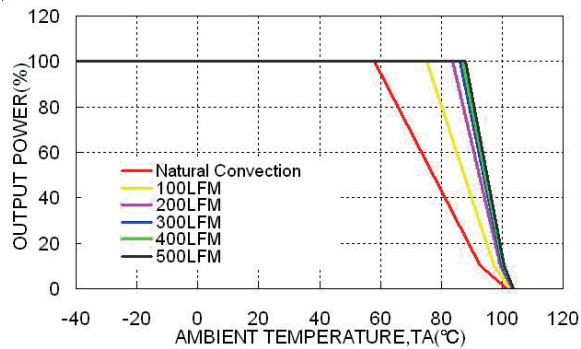

Derating Output Current versus Ambient Temperature with  
Heat-sink and Airflow, Vin(nom)

All test conditions are at 25°C. The figures are identical for PMF30-24S15W

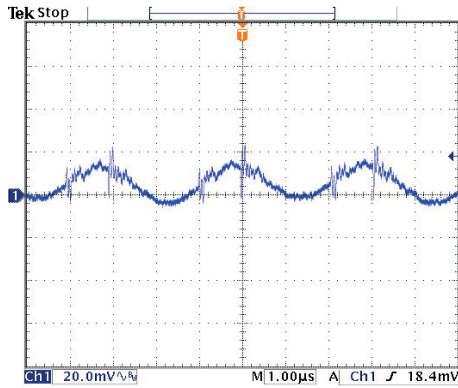

Typical Output Ripple and Noise.  
 $V_{in}(nom)$ ; Full Load

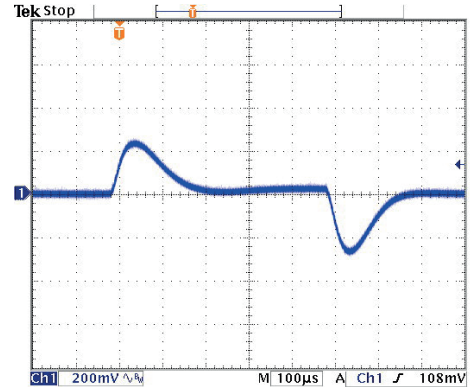

Transient Response to Dynamic Load Change from  
 100% to 75% to 100% of Full Load;  $V_{in}(nom)$

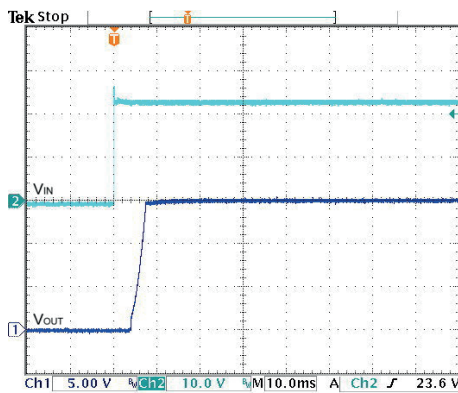

Typical Input Start-Up and Output Rise Characteristic  
 $V_{in}(nom)$ ; Full Load

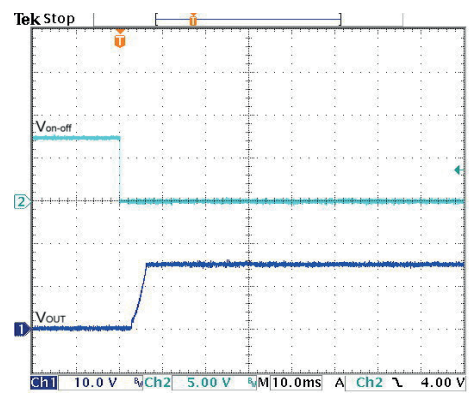

Using ON/OFF Voltage Start-Up and Output Rise Characteristic  
 $V_{in}(nom)$ ; Full Load

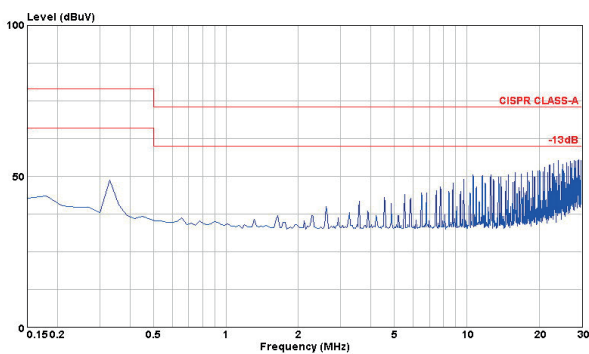

Conduction Emission of EN55022 Class A  
 $V_{in}(nom)$ ; Full Load

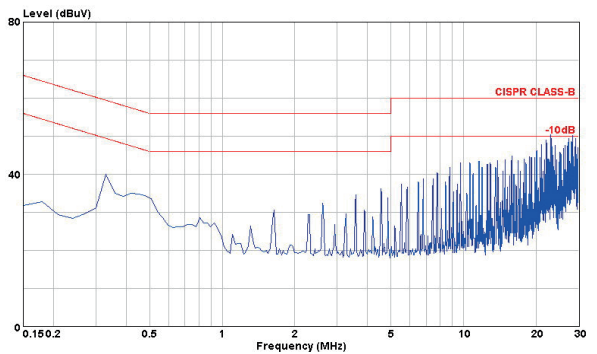

Conduction Emission of EN55022 Class B  
 $V_{in}(nom)$ ; Full Load

POWERBOX Industrial Line  
 PMF30W Series  
 30W 4:1 Single Output  
 DC/DC Converter  
 Manual

All test conditions are at 25°C. The figures are identical for PMF30-24S24W

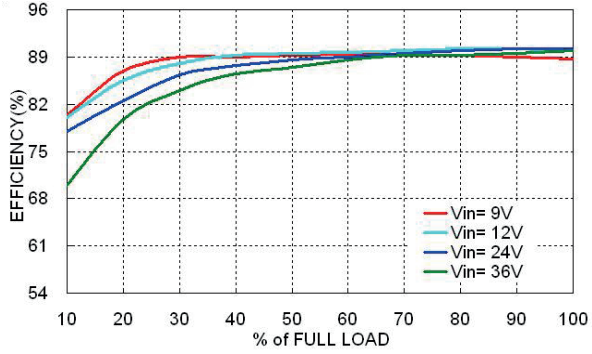

Efficiency versus Output Current

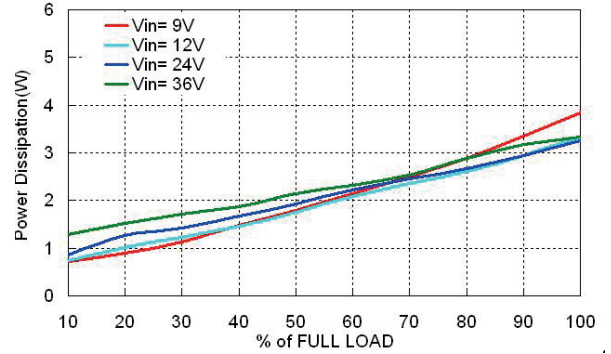

Power Dissipation versus Output Current

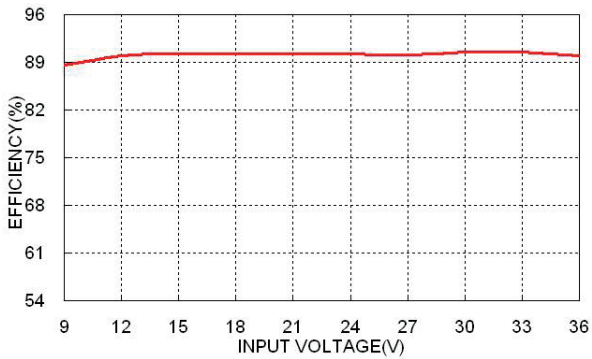

Efficiency versus Input Voltage Full Load

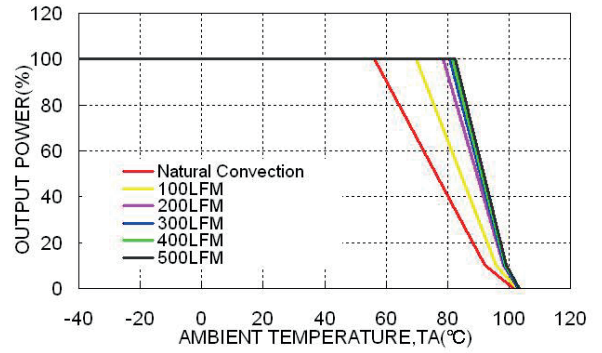

Derating Output Current versus Ambient Temperature and Airflow Vin(nom)

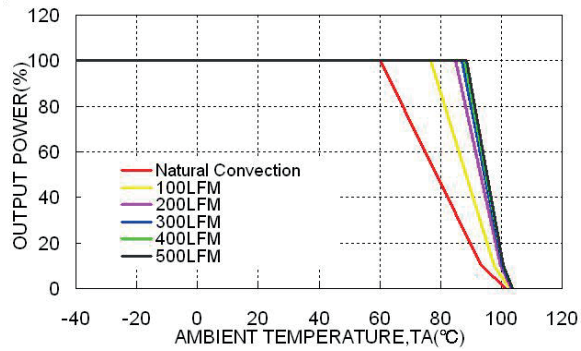

Derating Output Current versus Ambient Temperature with Heat-sink and Airflow, Vin(nom)

POWERBOX Industrial Line  
 PMF30W Series  
 30W 4:1 Single Output  
 DC/DC Converter  
 Manual

All test conditions are at 25°C. The figures are identical for PMF30-24S24W

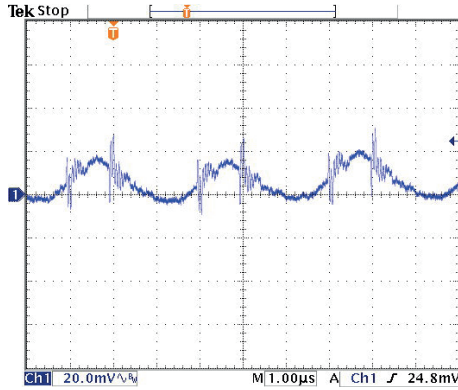

Typical Output Ripple and Noise.  
 $V_{in}(nom)$ ; Full Load

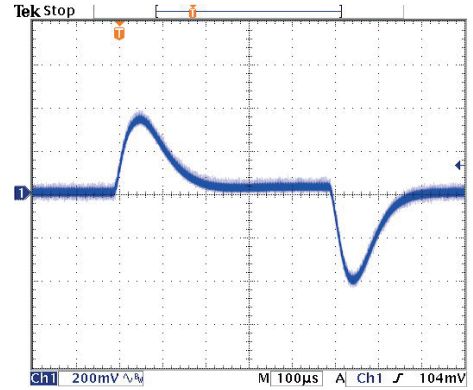

Transient Response to Dynamic Load Change from  
 100% to 75% to 100% of Full Load;  $V_{in}(nom)$

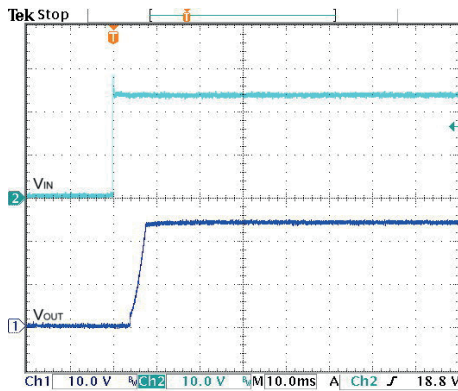

Typical Input Start-Up and Output Rise Characteristic  
 $V_{in}(nom)$ ; Full Load

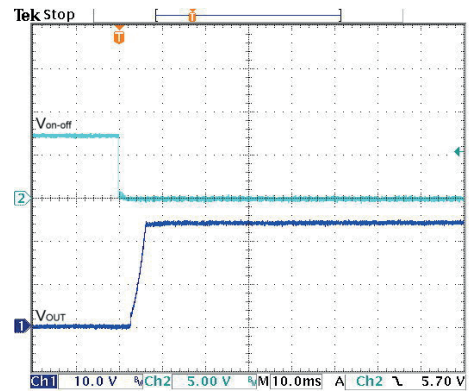

Using ON/OFF Voltage Start-Up and Output Rise Characteristic  
 $V_{in}(nom)$ ; Full Load

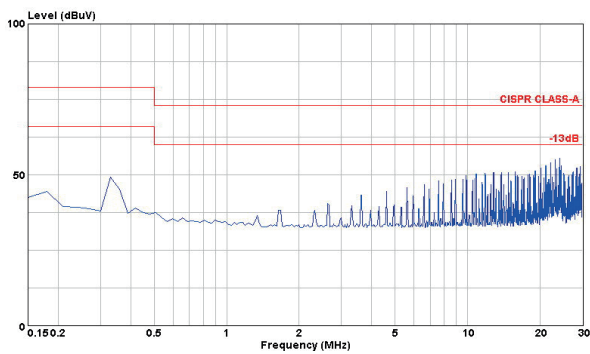

Conduction Emission of EN55022 Class A  
 $V_{in}(nom)$ ; Full Load

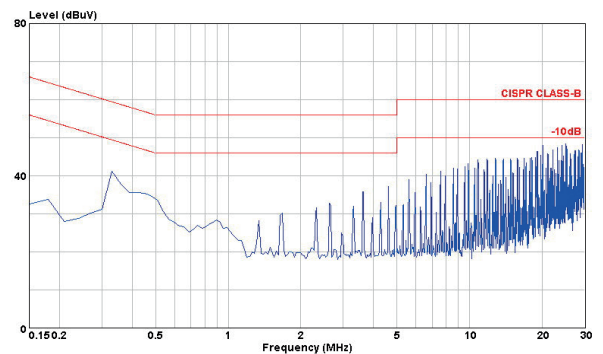

Conduction Emission of EN55022 Class B  
 $V_{in}(nom)$ ; Full Load

POWERBOX Industrial Line  
 PMF30W Series  
 30W 4:1 Single Output  
 DC/DC Converter  
 Manual

All test conditions are at 25°C. The figures are identical for PMF30-48S3P3W

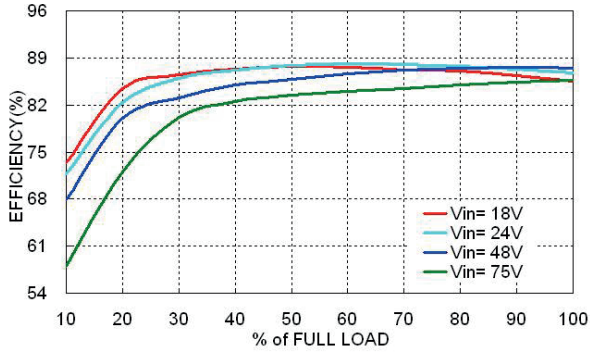

Efficiency versus Output Current

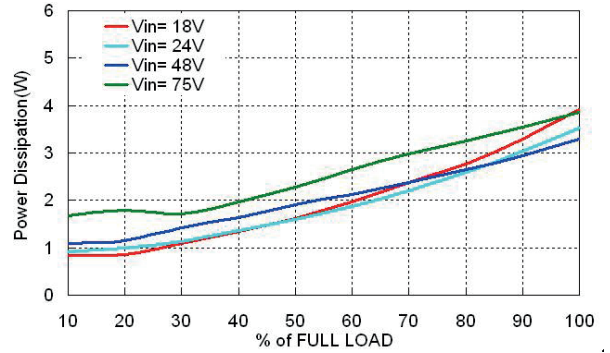

Power Dissipation versus Output Current

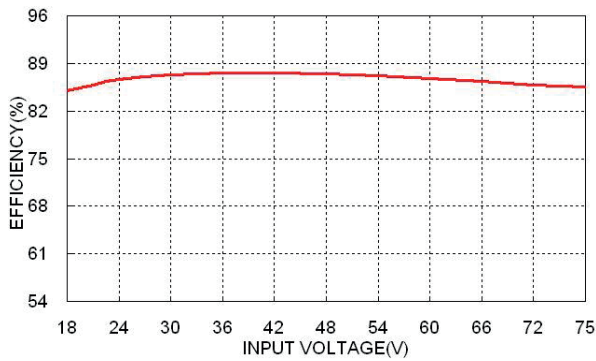

Efficiency versus Input Voltage Full Load

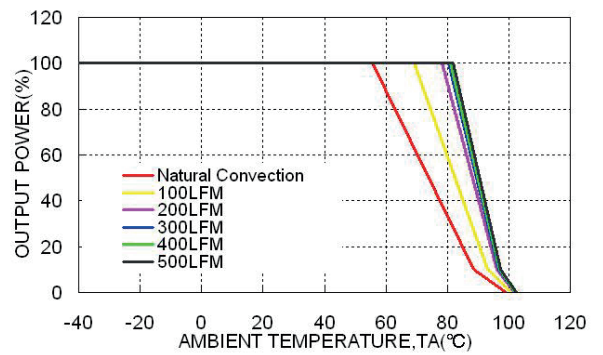

Derating Output Current versus Ambient Temperature and Airflow Vin(nom)

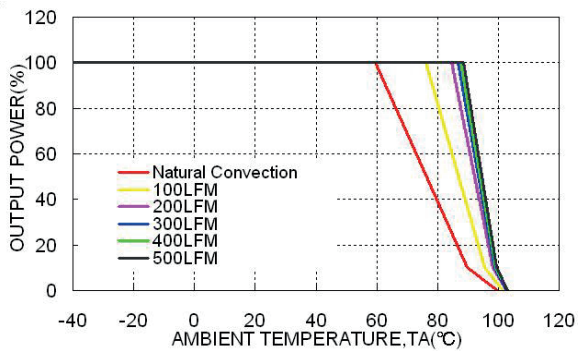

Derating Output Current versus Ambient Temperature with Heat-sink and Airflow, Vin(nom)

All test conditions are at 25°C. The figures are identical for PMF30-48S3P3W

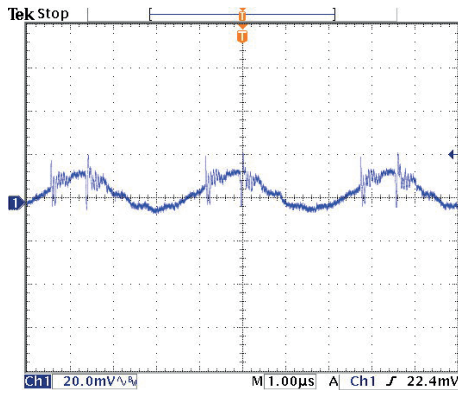

Typical Output Ripple and Noise.  
 $V_{in}(nom)$ ; Full Load

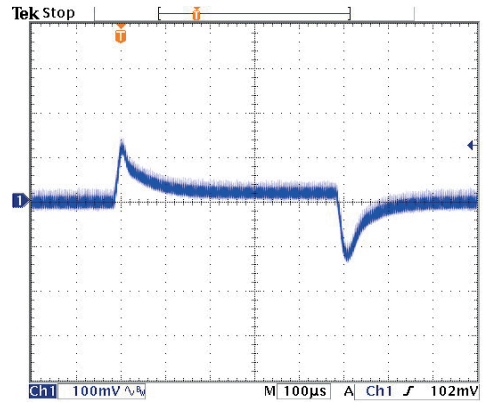

Transient Response to Dynamic Load Change from  
 100% to 75% to 100% of Full Load;  $V_{in}(nom)$

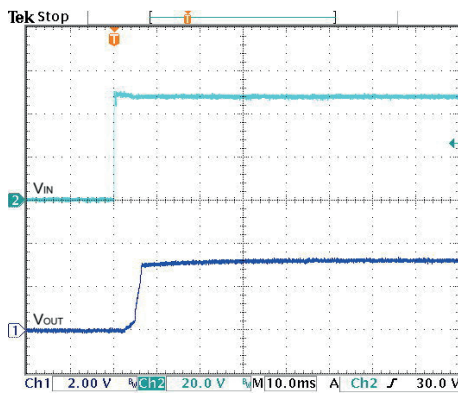

Typical Input Start-Up and Output Rise Characteristic  
 $V_{in}(nom)$ ; Full Load

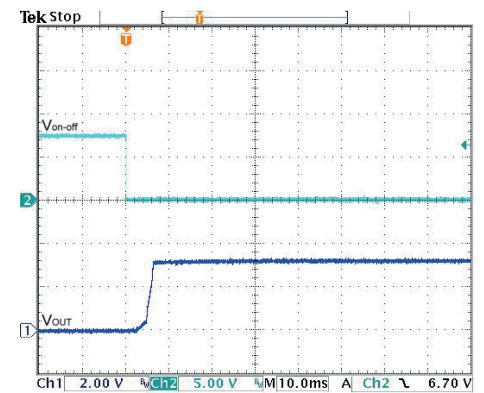

Using ON/OFF Voltage Start-Up and Output Rise Characteristic  
 $V_{in}(nom)$ ; Full Load

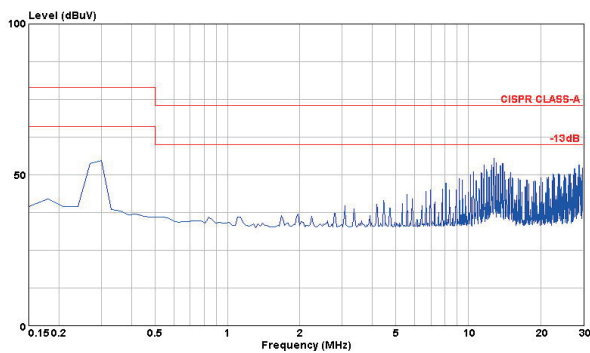

Conduction Emission of EN55022 Class A  
 $V_{in}(nom)$ ; Full Load

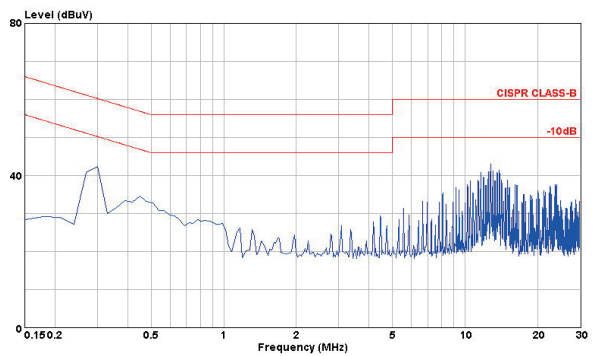

Conduction Emission of EN55022 Class B  
 $V_{in}(nom)$ ; Full Load



POWERBOX Industrial Line  
 PMF30W Series  
 30W 4:1 Single Output  
 DC/DC Converter  
 Manual

All test conditions are at 25°C. The figures are identical for PMF30-48S05W

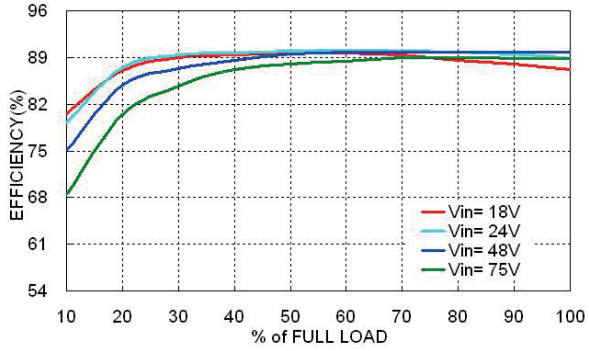

Efficiency versus Output Current

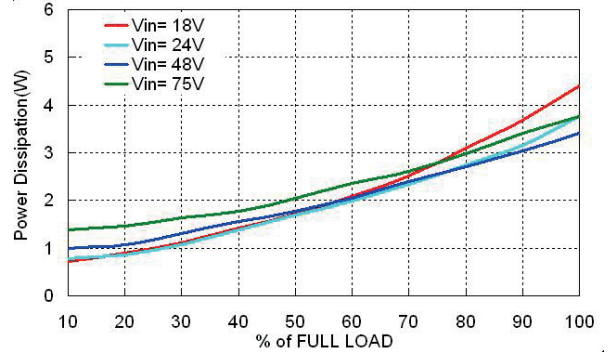

Power Dissipation versus Output Current

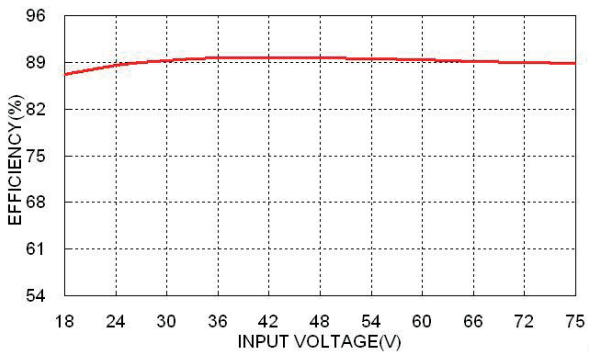

Efficiency versus Input Voltage  
Full Load

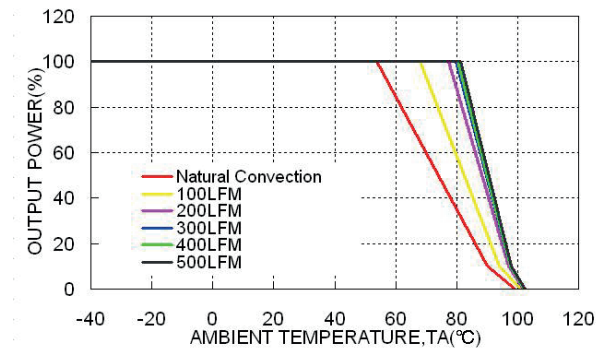

Derating Output Current versus Ambient Temperature and Airflow  
Vin(nom)

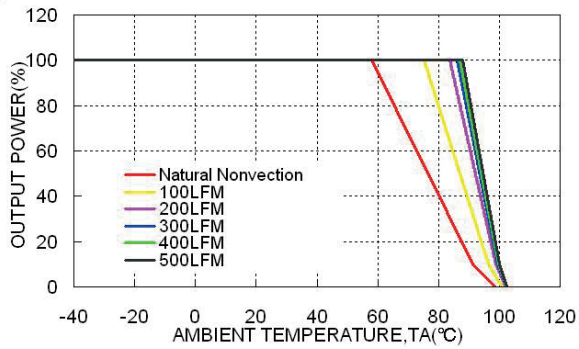

Derating Output Current versus Ambient Temperature with  
Heat-sink and Airflow, Vin(nom)

All test conditions are at 25°C. The figures are identical for PMF30-48S05W

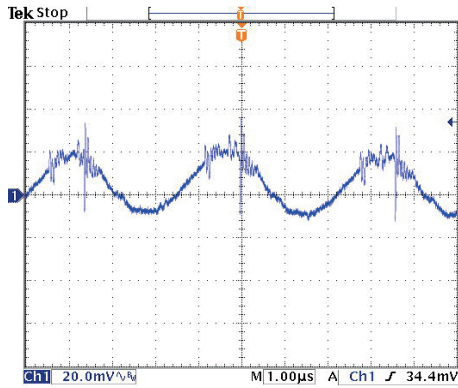

Typical Output Ripple and Noise.  
 $V_{in}(nom)$ ; Full Load

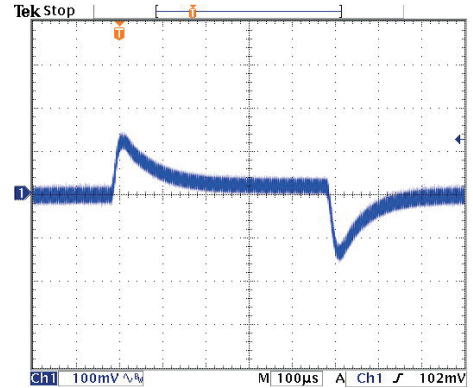

Transient Response to Dynamic Load Change from  
 100% to 75% to 100% of Full Load;  $V_{in}(nom)$

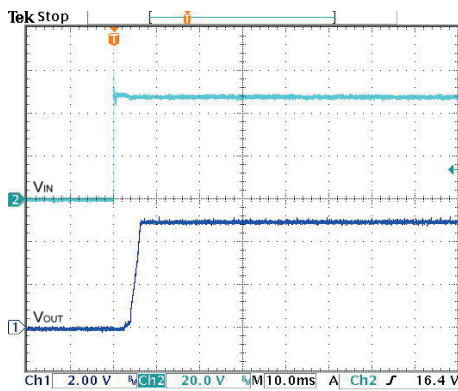

Typical Input Start-Up and Output Rise Characteristic  
 $V_{in}(nom)$ ; Full Load

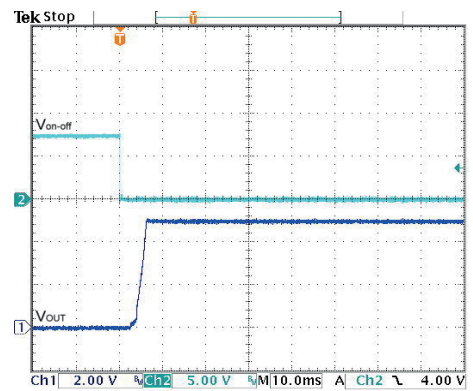

Using ON/OFF Voltage Start-Up and Output Rise Characteristic  
 $V_{in}(nom)$ ; Full Load

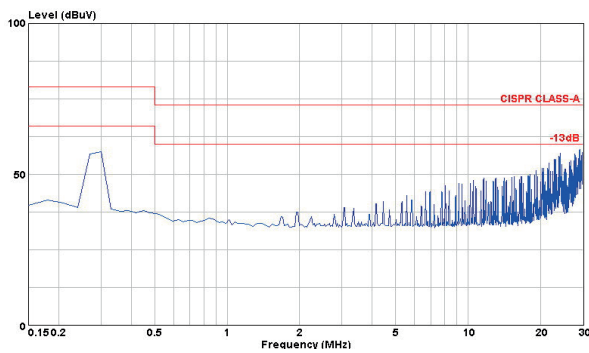

Conduction Emission of EN55022 Class A  
 $V_{in}(nom)$ ; Full Load

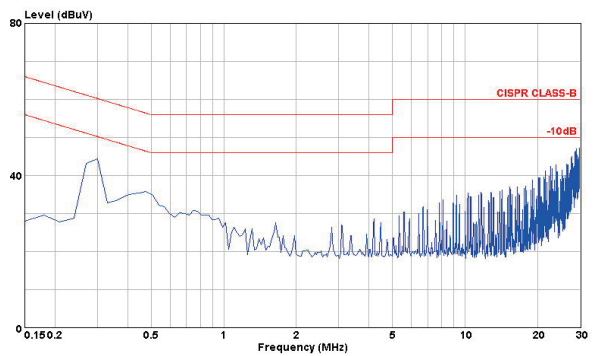

Conduction Emission of EN55022 Class B  
 $V_{in}(nom)$ ; Full Load

POWERBOX Industrial Line  
 PMF30W Series  
 30W 4:1 Single Output  
 DC/DC Converter  
 Manual

All test conditions are at 25°C. The figures are identical for PMF30-48S12W

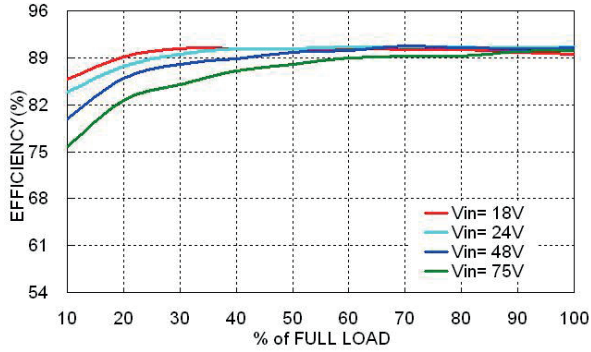

Efficiency versus Output Current

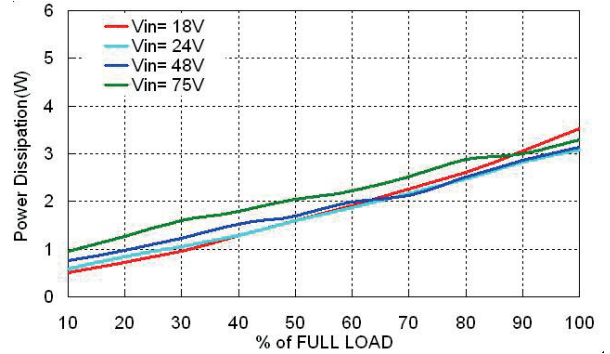

Power Dissipation versus Output Current

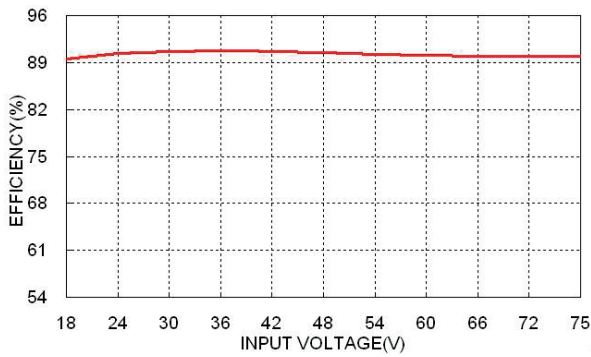

Efficiency versus Input Voltage Full Load

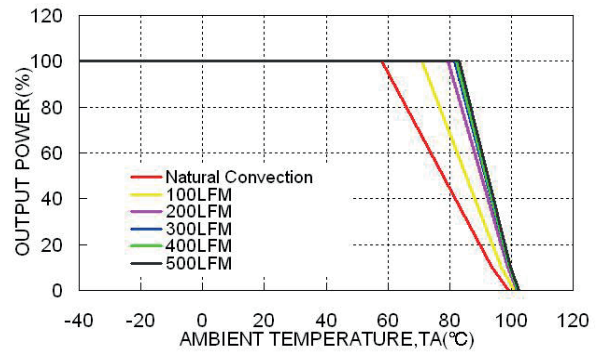

Derating Output Current versus Ambient Temperature and Airflow Vin(nom)

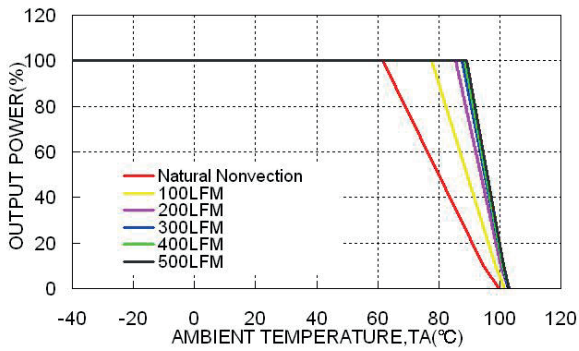

Derating Output Current versus Ambient Temperature with Heat-sink and Airflow, Vin(nom)

All test conditions are at 25°C. The figures are identical for PMF30-48S12W

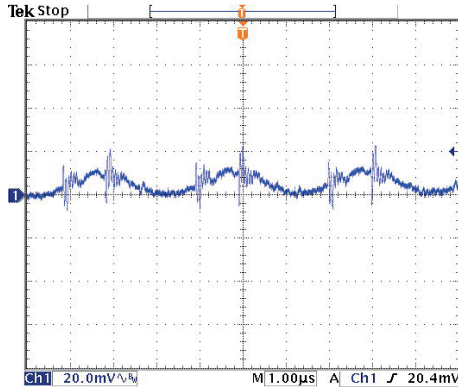

Typical Output Ripple and Noise.  
 $V_{in}(nom)$ ; Full Load

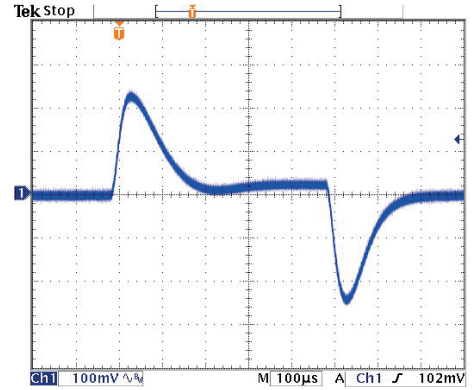

Transient Response to Dynamic Load Change from  
 100% to 75% to 100% of Full Load;  $V_{in}(nom)$

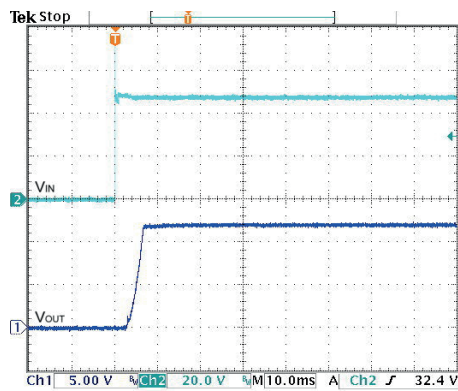

Typical Input Start-Up and Output Rise Characteristic  
 $V_{in}(nom)$ ; Full Load

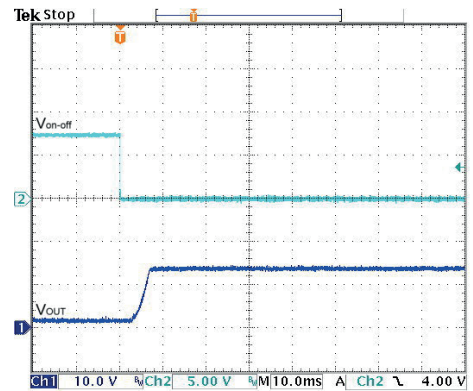

Using ON/OFF Voltage Start-Up and Output Rise Characteristic  
 $V_{in}(nom)$ ; Full Load

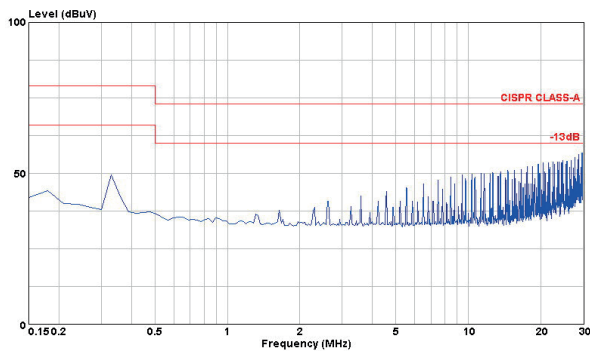

Conduction Emission of EN55022 Class A  
 $V_{in}(nom)$ ; Full Load

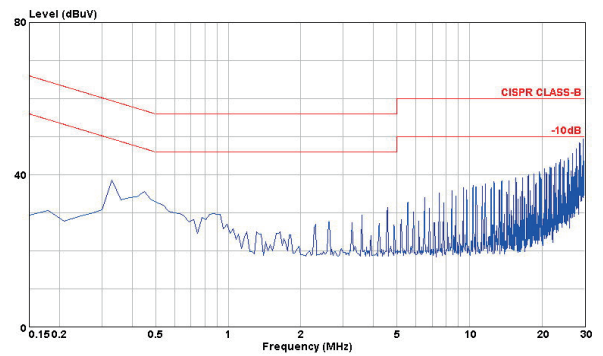

Conduction Emission of EN55022 Class B  
 $V_{in}(nom)$ ; Full Load

POWERBOX Industrial Line  
 PMF30W Series  
 30W 4:1 Single Output  
 DC/DC Converter  
 Manual

All test conditions are at 25°C. The figures are identical for PMF30-48S15W

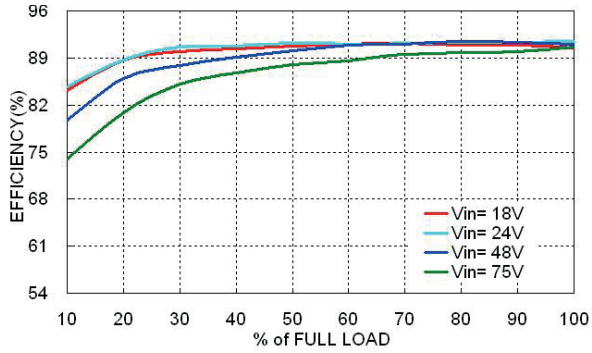

Efficiency versus Output Current

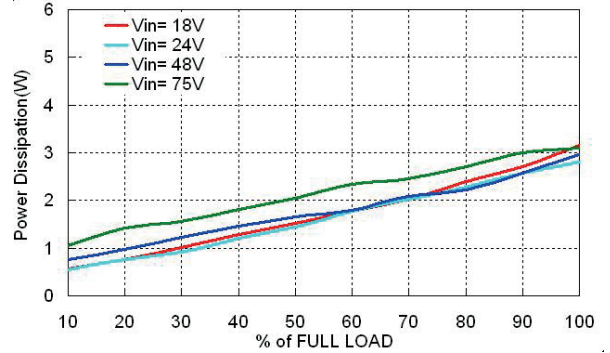

Power Dissipation versus Output Current

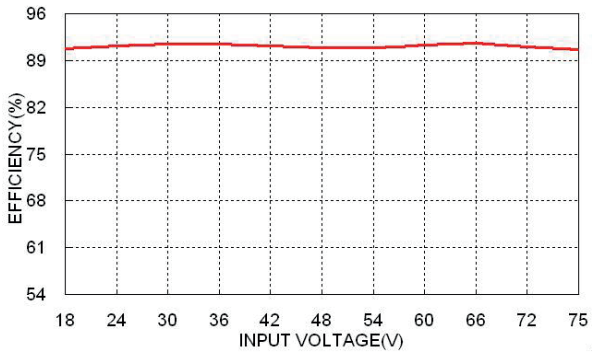

Efficiency versus Input Voltage Full Load

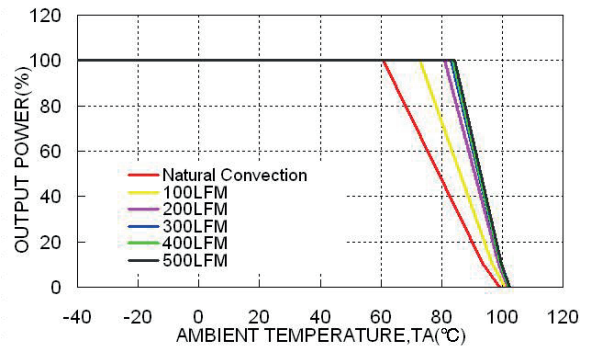

Derating Output Current versus Ambient Temperature and Airflow V<sub>in</sub>(nom)

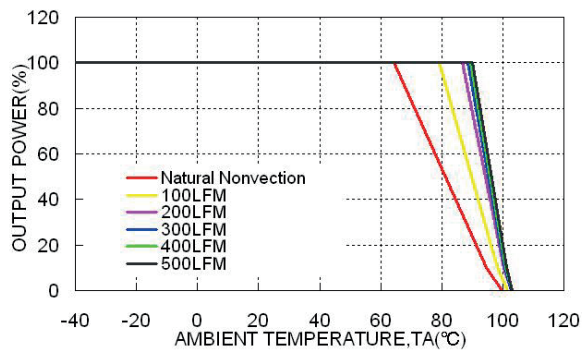

Derating Output Current versus Ambient Temperature with Heat-sink and Airflow, V<sub>in</sub>(nom)

All test conditions are at 25°C. The figures are identical for PMF30-48S15W

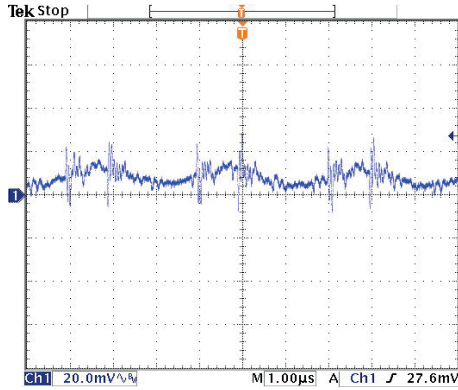

Typical Output Ripple and Noise.  
 $V_{in}(nom)$ ; Full Load

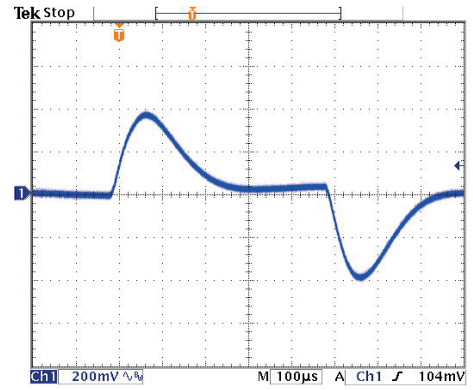

Transient Response to Dynamic Load Change from  
 100% to 75% to 100% of Full Load;  $V_{in}(nom)$

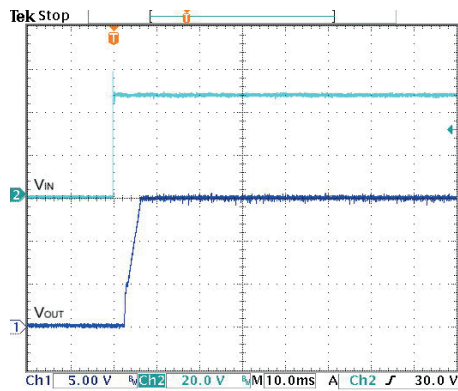

Typical Input Start-Up and Output Rise Characteristic  
 $V_{in}(nom)$ ; Full Load

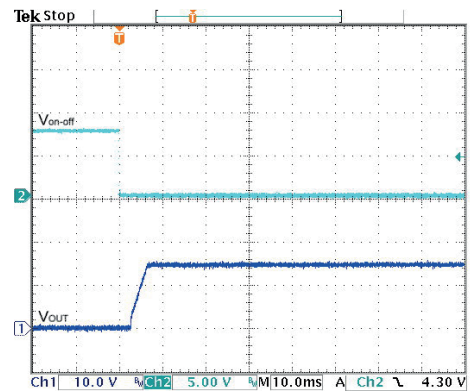

Using ON/OFF Voltage Start-Up and Output Rise Characteristic  
 $V_{in}(nom)$ ; Full Load

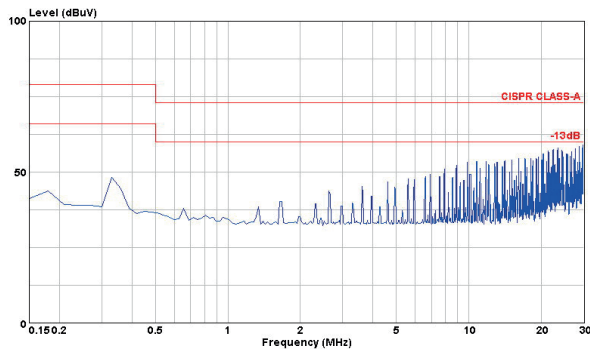

Conduction Emission of EN55022 Class A  
 $V_{in}(nom)$ ; Full Load

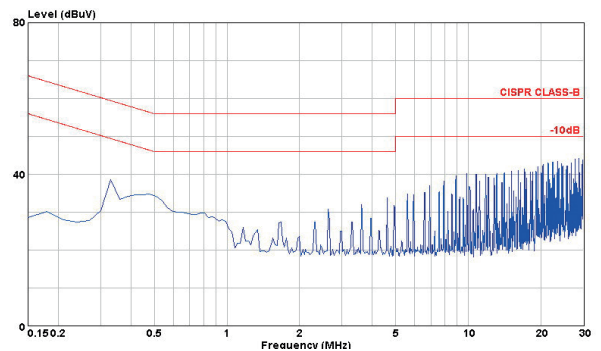

Conduction Emission of EN55022 Class B  
 $V_{in}(nom)$ ; Full Load

POWERBOX Industrial Line  
 PMF30W Series  
 30W 4:1 Single Output  
 DC/DC Converter  
 Manual

All test conditions are at 25°C. The figures are identical for PMF30-48S24W

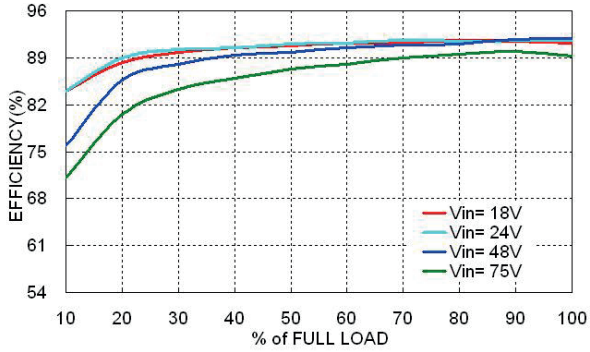

Efficiency versus Output Current

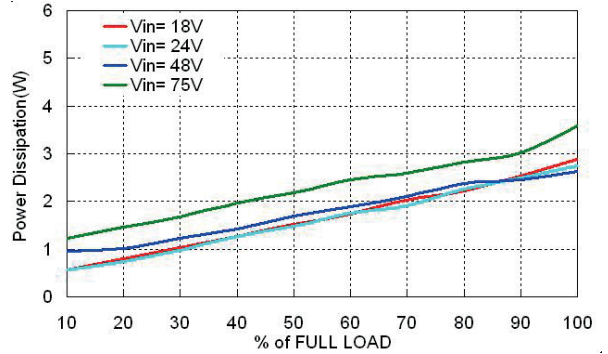

Power Dissipation versus Output Current

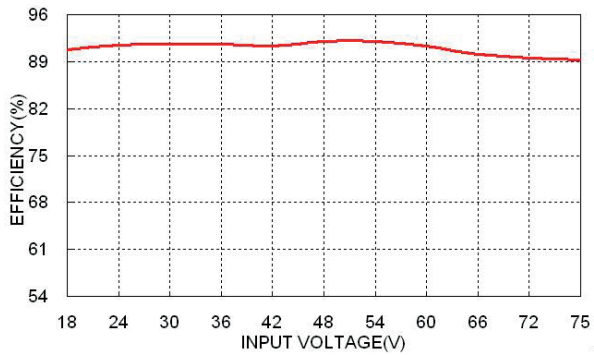

Efficiency versus Input Voltage Full Load

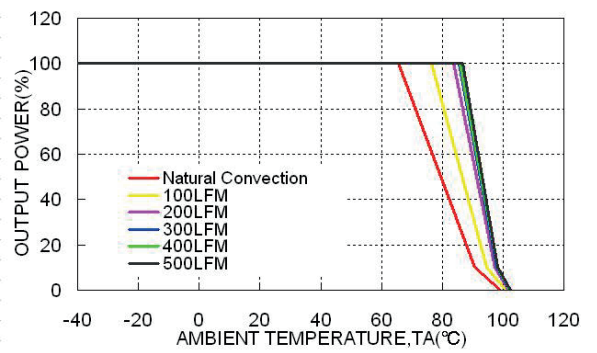

Derating Output Current versus Ambient Temperature and Airflow Vin(nom)

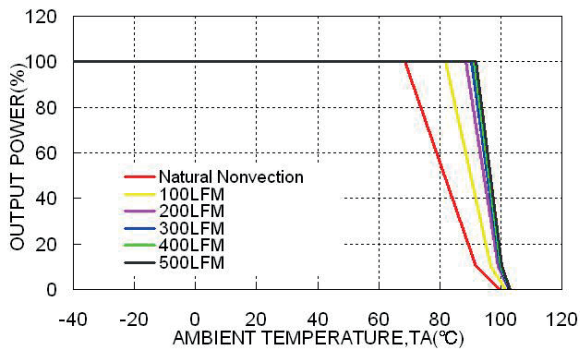

Derating Output Current versus Ambient Temperature with Heat-sink and Airflow, Vin(nom)

All test conditions are at 25°C. The figures are identical for PMF30-48S24W

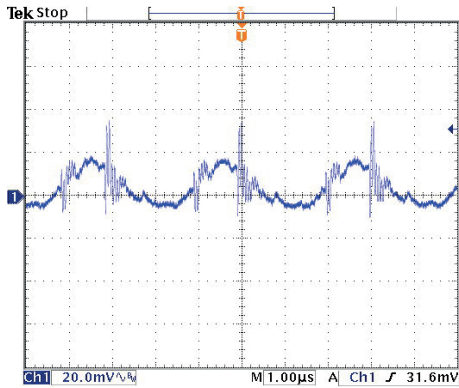

Typical Output Ripple and Noise.  
 $V_{in}(nom)$ ; Full Load

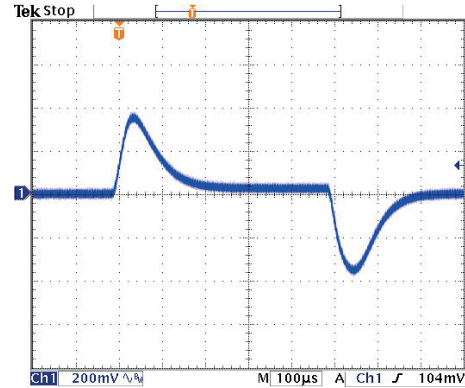

Transient Response to Dynamic Load Change from  
 100% to 75% to 100% of Full Load;  $V_{in}(nom)$

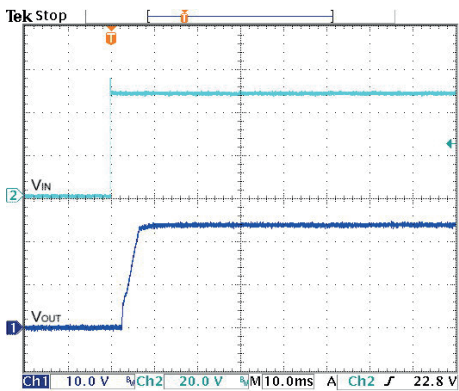

Typical Input Start-Up and Output Rise Characteristic  
 $V_{in}(nom)$ ; Full Load

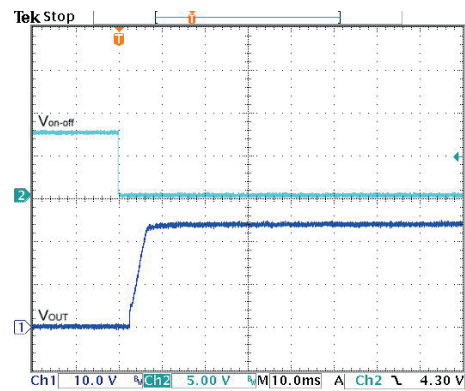

Using ON/OFF Voltage Start-Up and Output Rise Characteristic  
 $V_{in}(nom)$ ; Full Load

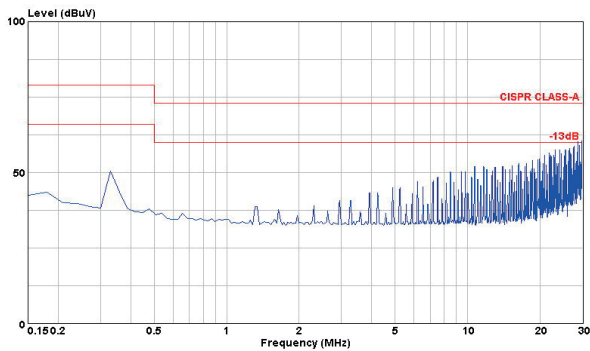

Conduction Emission of EN55022 Class A  
 $V_{in}(nom)$ ; Full Load

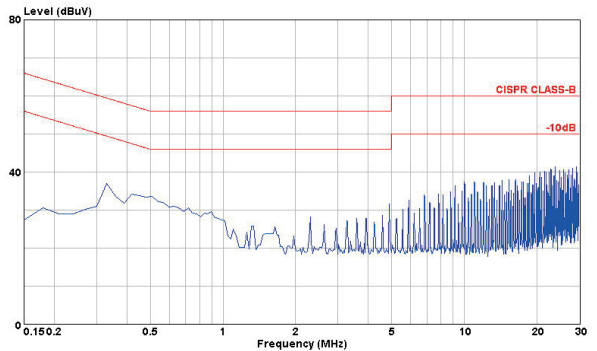

Conduction Emission of EN55022 Class B  
 $V_{in}(nom)$ ; Full Load



### Output Voltage Adjustment

Output voltage set point adjustment allows the user to increase or decrease the output voltage set point of the module. This is accomplished by connecting an external resistor between the TRIM pin and either the +OUTPUT or -OUTPUT pins. With an external resistor between the TRIM and -OUTPUT pin, the output voltage set point increases. With an external resistor between the TRIM and +OUTPUT pin, the output voltage set point decreases. The external TRIM resistor needs to be at least 1/16W of rated power.

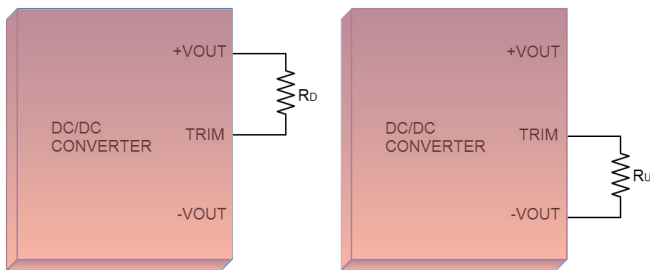

### Trim up equation

$$R_U = \left[ \frac{G \times L}{(V_{O,up} - L - K)} - H \right] \Omega$$

### Trim down equation

$$R_D = \left[ \frac{(V_{O,down} - L) \times G}{(V_o - V_{O,down})} - H \right] \Omega$$

### Trim constants

Module	G	H	K	L
PMF30-□□S3P3W	5110	2050	0.8	2.5
PMF30-□□S05W	5110	2050	2.5	2.5
PMF30-□□S12W	10000	5110	9.5	2.5
PMF30-□□S15W	10000	5110	12.5	2.5
PMF30-□□S24W	56000	13000	21.5	2.5

Output voltage adjustment configurations

### Trim Table

PMF30-□□S3P3W		Trim-Up									
Trim-Up (%)		1	2	3	4	5	6	7	8	9	10
Vout (V)		3.333	3.366	3.399	3.432	3.465	3.498	3.531	3.564	3.597	3.630
RU (kΩ)		385.071	191.511	126.990	94.730	75.374	62.470	53.253	46.340	40.963	36.662

PMF30-□□S3P3W		Trim-Down									
Trim-Down (%)		1	2	3	4	5	6	7	8	9	10
Vout (V)		3.267	3.234	3.201	3.168	3.135	3.102	3.069	3.036	3.003	2.970
RD (kΩ)		116.719	54.779	34.133	23.810	17.616	13.486	10.537	8.325	6.604	5.228

PMF30-□□S05W		Trim-Up									
Trim-Up (%)		1	2	3	4	5	6	7	8	9	10
Vout (V)		5.050	5.100	5.150	5.200	5.250	5.300	5.350	5.400	5.450	5.500
RU (kΩ)		253.450	125.700	83.117	61.825	49.050	40.533	34.450	29.888	26.339	23.500

PMF30-□□S05W		Trim-Down									
Trim-Down (%)		1	2	3	4	5	6	7	8	9	10
Vout (V)		4.950	4.900	4.850	4.800	4.750	4.700	4.650	4.600	4.550	4.500
RD (kΩ)		248.340	120.590	78.007	56.715	43.940	35.423	29.340	24.778	21.229	18.390

PMF30-□□S12W		Trim-Up									
Trim-Up (%)		1	2	3	4	5	6	7	8	9	10
Vout (V)		12.120	12.240	12.360	12.480	12.600	12.720	12.840	12.960	13.080	13.200
RU (kΩ)		203.223	99.057	64.334	46.973	36.557	29.612	24.652	20.932	18.038	15.723

PMF30-□□S12W		Trim-Down									
Trim-Down (%)		1	2	3	4	5	6	7	8	9	10
Vout (V)		11.880	11.760	11.640	11.520	11.400	11.280	11.160	11.040	10.920	10.800
RD (kΩ)		776.557	380.723	248.779	182.807	143.223	116.834	97.985	83.848	72.853	64.057

PMF30-□□S15W		Trim-Up									
Trim-Up (%)		1	2	3	4	5	6	7	8	9	10
Vout (V)		15.150	15.300	15.450	15.600	15.750	15.900	16.050	16.200	16.350	16.500
RU (kΩ)		161.557	78.223	50.446	36.557	28.223	22.668	18.700	15.723	13.409	11.557

PMF30-□□S15W		Trim-Up									
Trim-Up (%)		11	12	13	14	15	16	17	18	19	20
Vout (V)		16.650	16.800	16.950	17.100	17.250	17.400	17.550	17.700	17.850	18.000
RU (kΩ)		10.042	8.779	7.711	6.795	6.001	5.307	4.694	4.149	3.662	3.223

PMF30-□□S15W		Trim-Down									
Trim-Down (%)		1	2	3	4	5	6	7	8	9	10
Vout (V)		14.850	14.700	14.550	14.400	14.250	14.100	13.950	13.800	13.650	13.500
RD (kΩ)		818.223	401.557	262.668	193.223	151.557	123.779	103.938	89.057	77.483	68.223

PMF30-□□S24W		Trim-Up									
Trim-Up (%)		1	2	3	4	5	6	7	8	9	10
Vout (V)		24.240	24.480	24.720	24.960	25.200	25.440	25.680	25.920	26.160	26.400
RU (kΩ)		570.333	278.667	181.444	132.833	13.667	84.222	70.333	59.917	51.815	45.333

PMF30-□□S24W		Trim-Up									
Trim-Up (%)		11	12	13	14	15	16	17	18	19	20
Vout (V)		26.640	26.880	27.120	27.360	27.600	27.840	28.080	28.320	28.560	28.800
RU (kΩ)		40.030	35.611	31.872	28.667	25.889	23.458	21.314	19.407	17.702	16.167

PMF30-□□S24W		Trim-Down									
Trim-Down (%)		1	2	3	4	5	6	7	8	9	10
Vout (V)		23.760	23.520	23.280	23.040	22.800	22.560	22.320	22.080	21.840	21.600
RD (kΩ)		4947.667	2439.333	1603.222	1185.167	934.333	767.111	647.667	558.083	488.407	432.667

### Input Source Impedance

The power modules operate as specifications without external components, assuming that the source voltage has a very low impedance and reasonable input voltage regulation. Highly inductive source impedances can affect the stability of the power module.

Install CSIM and LSIM to simulate the impedance of power source. External capacitors CFILTER serve primarily as energy-storage elements, minimizing line voltage variations caused by transient IR drops in conductors from backplane to the DC/DC. The capacitor must as close as possible to the input terminals of the power module for lower impedance. For the input reflected-ripple current measurement configuration is shown as below:

### Input reflected ripple current measurement

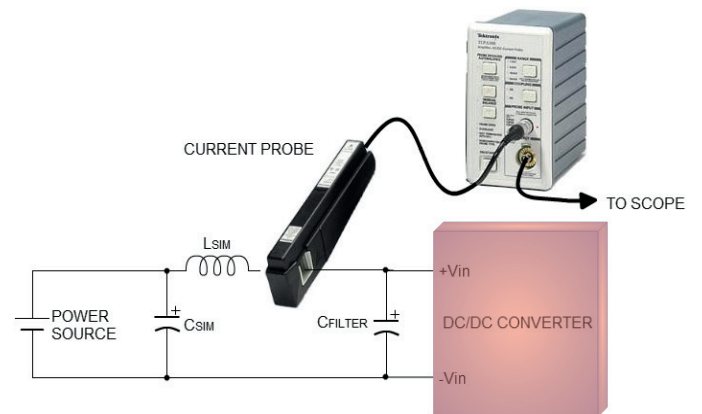

### PMF30-□□S□□W

Component	Value	Voltage	Reference
LSIM	12μH	----	Inductor
CSIM CFILTER	10μF	100V	Nippon chemi-con KY-series

### Output Over Current Protection

When excessive output currents occur in the system, circuit protection is required on all power supplies. Normally, overload current is maintained at approximately 170 percent of rated current for PMF30W single output series.

Hiccup-mode is a method of operation in a power supply whose purpose is to protect the power supply from being damaged during an over-current fault condition. It also enables the power supply to restart when the fault is removed. There are other ways of protecting the power supply when it is over-loaded, such as the maximum current limiting or current fold-back methods.

One of the problems resulting from over current is that excessive heat may be generated in power devices; especially MOSFET and Schottky diodes and the temperature of those devices may exceed their specified limits. A protection mechanism has to be used to prevent those power devices from being damaged.

The operation of hiccup is as follows. When the current sense circuit sees an over-current event, the controller shuts off the power supply for a given time and then tries to start up the power supply again. If the overload condition has been removed, the power supply will start up and operate normally; otherwise, the controller will see another over-current event and shut off the power supply again, repeating the previous cycle. Hiccup operation has none of the drawbacks of the other two protection methods, although its circuit is more complicated because it requires a timing circuit. The excess heat due to overload lasts for only a short duration in the hiccup cycle, hence the junction temperature of the power devices is much lower.

The hiccup operation can be done in various ways. For example, one can start hiccup operation any time an over-current event is detected; or prohibit hiccup during a designated start-up is usually larger than during normal operation and it is easier for an over-current event is detected; or prohibit hiccup during a designated start-up interval (usually a few milliseconds). The reason for the latter operation is that during start-up, the power supply needs to provide extra current to charge up the output capacitor. Thus the current demand during start-up is usually larger than during normal operation and it is easier for an over-current event to occur. If the power supply starts to hiccup once there is an over-current, it might never start up successfully. Hiccup mode protection will give the best protection for a power supply against over current situations, since it will limit the average current to the load at a low level, so reducing power dissipation and case temperature in the power devices.

### Output Short Circuitry Protection

Continuous, auto-recovery mode. During short circuit, converter still shut down. The average current during this condition will be very low and the device can be safety in this condition.

### Output Over Voltage Protection

The output over-voltage protection consists of Zener diode that monitors the output voltage on the feedback loop. If the voltage on the output terminals exceeds the over-voltage protection threshold, then the Zener diode will send a current signal to the control IC to limiting the output voltage.

### Thermal Consideration

The power module operates in a variety of thermal environments. However, sufficient cooling should be provided to help ensure reliable operation of the unit. Heat is removed by conduction, convection, and radiation to the surrounding environment. Proper cooling can be verified by measuring the point as the figure below. The temperature at this location should not exceed 105°C. When operating, adequate cooling must be provided to maintain the test point temperature at or below 105°C. Although the maximum point temperature of the power modules is 105°C, you can limit this temperature to a lower value for extremely high reliability.

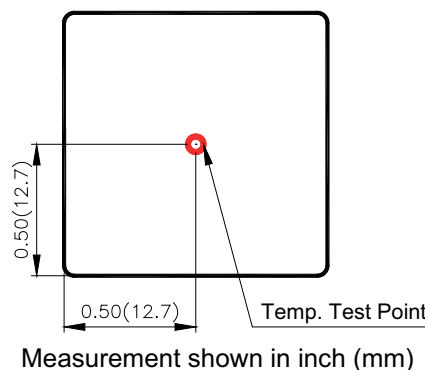

### Heat-Sink Considerations

Equip heat-sink for lower temperature and higher reliability of the module. There are two types for choosing.

Suffix – HC : Heat-sink + Clamp

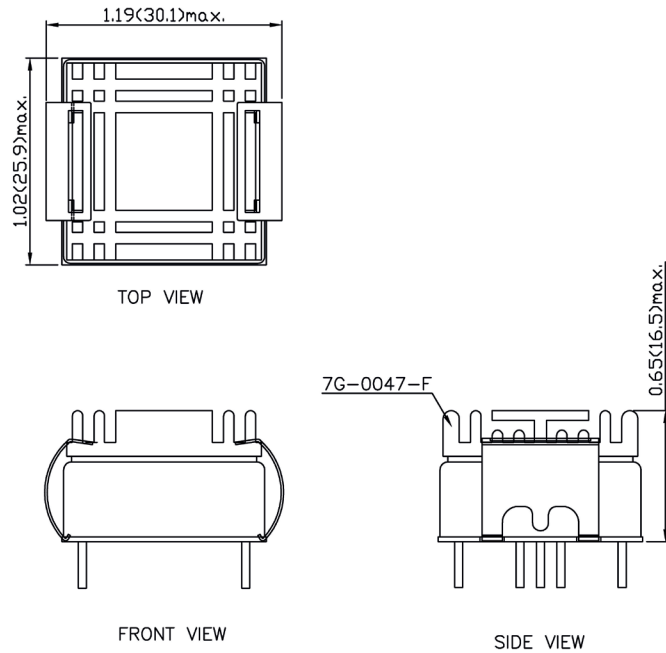

Suffix – HS : Heat-sink

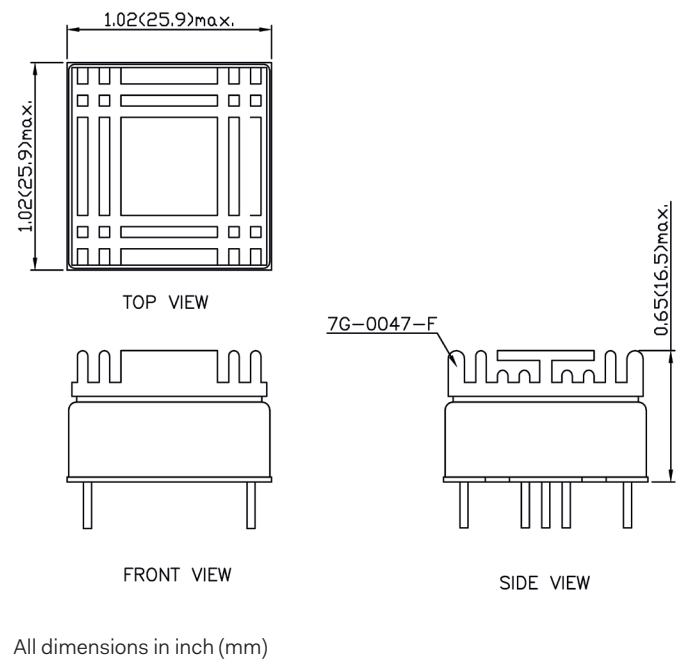

Remote On/Off Control

The Ctrl Pin is controlled DC/DC power module to turn on and off, the user must use a switch to control the logic voltage high or low level of the pin referenced to -Vin. The switch can be open collector transistor, FET and Photo-Coupler. The switch must be capable of sinking up to 1 mA at low-level logic voltage. High-level logic of the Ctrl pin signal maximum voltage is allowable leakage current of the switch at 12V is 0.5 mA.

Remote ON/OFF Implementation

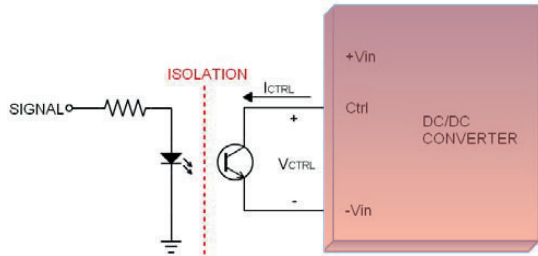

Isolated-Closure Remote ON/OFF

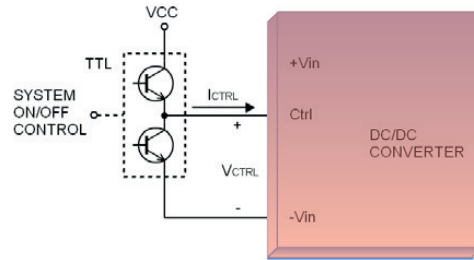

Level Control Using TTL Output

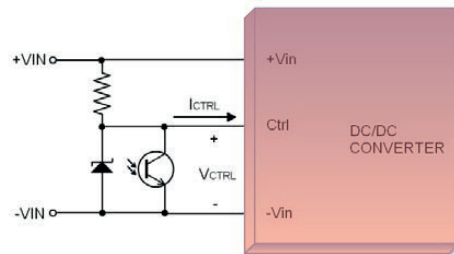

Level Control Using Line Voltage

There are two remote control options available, positive logic and negative logic.

a. The positive logic structure turned on of the DC/DC module when the Ctrl pin is at high-level logic and low-level logic is turned off it.

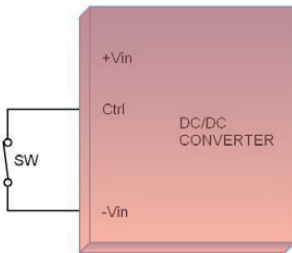

When PMF30W module is turned off at Low-level logic

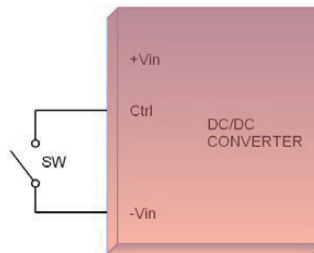

When PMF30W module is turned on at High-level logic

b. The negative logic structure turned on of the DC/DC module when the Ctrl pin is at low-level logic and turned off when at high-level logic.

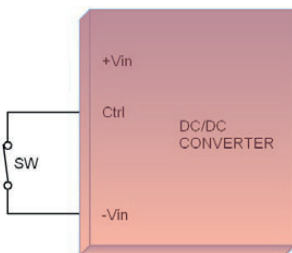

When PMF30W module is turned on at Low-level logic

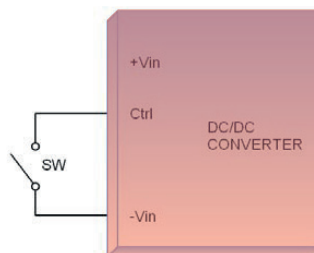

When PMF30W module is turned off at High-level logic

### EMS Considerations

The PMF30 series can meet Fast Transient EN61000-4-4 and Surge EN61000-4-5 performance criteria A with external components connected to the input terminals of the module. Please see the following schematics as below.

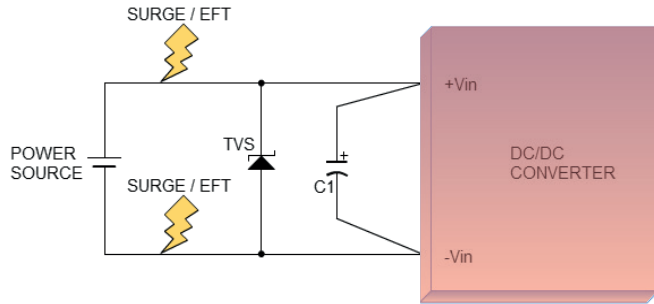

### Surge/Fast Transient

#### PMF30-24S□□W

Component	Value	Voltage	Reference
C1	220 $\mu$ F	100V	Nippon chemi-con KY-series
TVS	3000W (peak pulse power)	58V	Littelfuse,SMDJ58A

#### PMF30-48S□□W

Component	Value	Voltage	Reference
C1	220 $\mu$ F	100V	Nippon chemi-con KY-series

### Mechanical Data

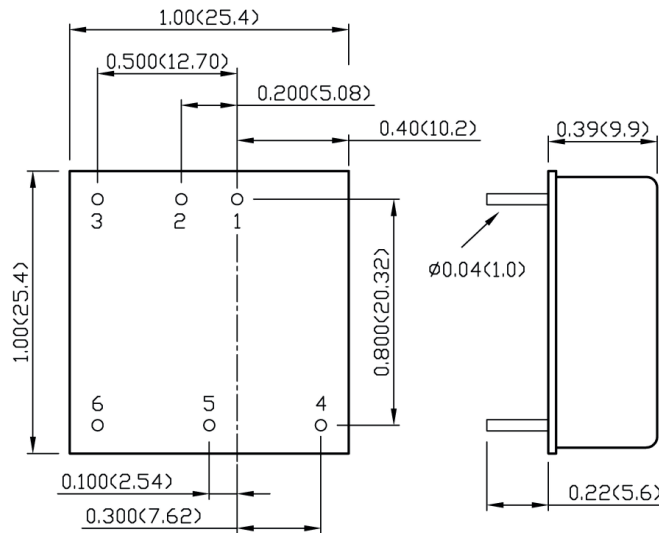

BOTTOM VIEW

- All dimensions in inch (mm)
- Tolerance: X.XX $\pm$ 0.02 (X.X $\pm$ 0.5)  
X.XXX $\pm$ 0.01 (X.XX $\pm$ 0.25)
- Pin pitch tolerance  $\pm$ 0.01(0.25)
- Pin dimension tolerance  $\pm$ 0.004 (0.1)

### Pin Connection

Pin	Define
1	+Vin
2	-Vin
3	Ctrl
4	+Vout
5	Trim
6	-Vout

### Recommended Pad Layout

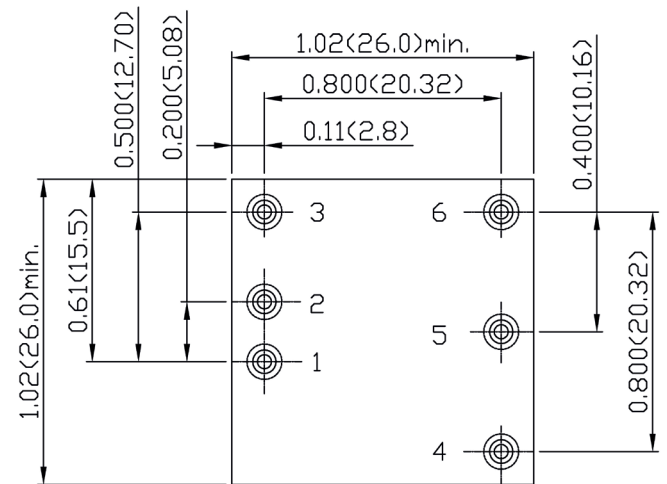

All dimensions in inch(mm)

Pad size(lead free recommended)

Through hole: $\phi$ 0.051( $\phi$ 1.30)

Top view pad: $\phi$ 0.064( $\phi$ 1.63)

Bottom view pad: $\phi$ 0.102( $\phi$ 2.60)

### Soldering Considerations

Lead free wave solder profile

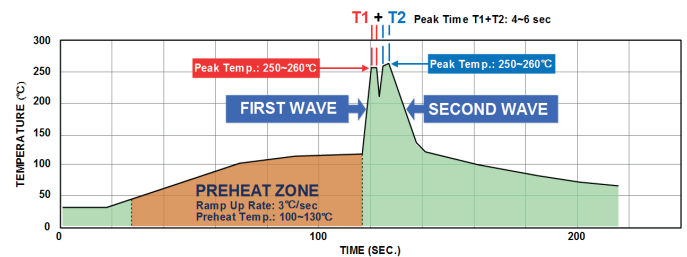

Reference Solder: Sn-Ag-Cu: Sn-Cu

Hand Welding (Reference):

Soldering iron: Power 150W

Welding Time: 3~6 sec

Temp: 410~430°C

### Packing Information

Tube

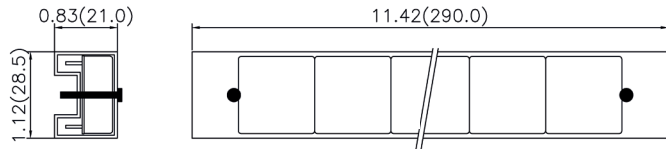

Tray

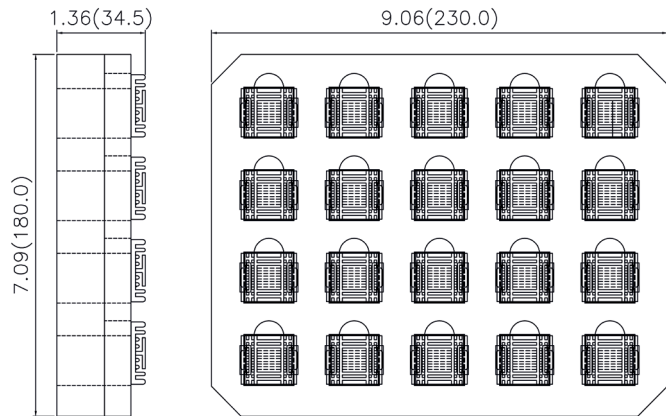

Model Type	Packing Material	Quantity
Without Heat-sink	Tube	10 PCS / Tube
With Heat-sink	Tray	20 PCS / Tray

### Safety and Installation Instruction

Fusing Consideration

Caution: This power module is not internally fused. An input line fuse must always be used. This encapsulated power module can be used in a wide variety of applications, ranging from simple stand-alone operation to an integrated part of sophisticated power architecture. To maximum flexibility, internal fusing is not included; however, to achieve maximum safety and system protection, always use an input line fuse. The input line fuse suggest as below:

Model	Fuse Rating	Fuse Type
PMF30-24S□□W	6	Slow-Blow
PMF30-48S□□W	3	Slow-Blow

Based on the information provided in this application note on Inrush energy and maximum DC input current at low Vin. If customer have another used condition and need more information, please contact Powerbox.

### MTBF and Reliability

The MTBF of PMF30W SINGLE-SERIES of DC/DC converters has been calculated using MIL-HDBK 217F at Tc=70°C FULL LOAD. The resulting figure for MTBF is 1.259x10<sup>6</sup> hours.

**Recommended external EMI filter for EN55022 Class A**

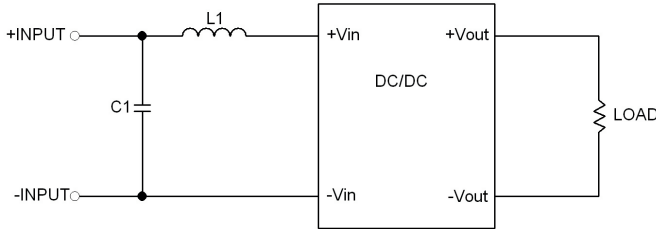

Single Output

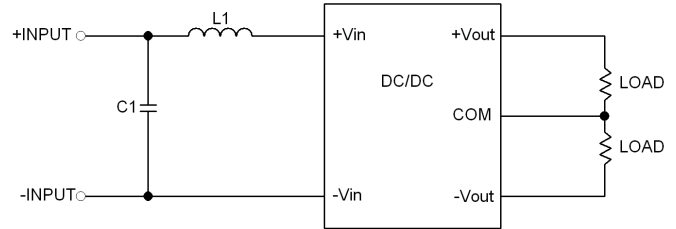

Dual Output

Model	C1	L1
PMF30-24□□□W	4.7μF/50V 1812 MLCC	2.2μH 11A 0.012Ω 0705 SMD Inductor, PMT-097
PMF30-48□□□W	4.7μF/100V 1812 MLCC	10μH 2.6A 0.04Ω 0705 SMD Inductor, PMT-070

**Recommended external EMI filter for EN55022 Class B**

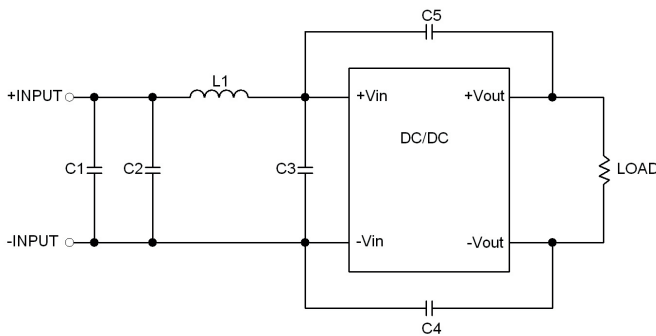

Single Output

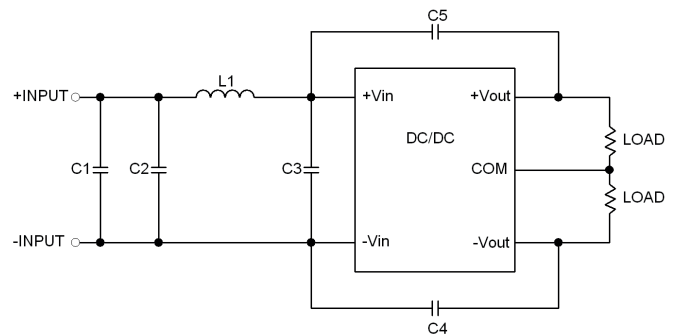

Dual Output

Model	C1	C2	C3	C4, C5	L1
PMF30-24□□□W	4.7μF/50V 1812 MLCC	4.7μF/50V 1812 MLCC	4.7μF/50V 1812 MLCC	1000pF/2kV 1206 MLCC	2.2μH 11A 0.012Ω 0705 SMD Inductor, PMT-097
PMF30-48□□□W	2.2μF/100V 1812 MLCC	2.2μF/100V 1812 MLCC	2.2μF/100V 1812 MLCC	1000pF/2kV 1808 MLCC	10μH 2.6A 0.04Ω 0705 SMD Inductor, PMT-070